

Kurt J. Lesker
Company

Series 947

Digital
Convection Enhanced Pirani (CEP)
Vacuum Sensor System

**OPERATION AND
MAINTENANCE MANUAL**

Kurt J. Lesker Company

Series 947

Digital Convection Enhanced Pirani (CEP) Vacuum Sensor System

Part #100014431

Series 947

Part # K _____

Serial # _____

Please fill in these numbers and have them readily available when calling for service or additional information.

(The part number can be found on your packing slip, and the serial number is located on the back panel of the controller.)

For more information or literature, contact:

Kurt J. Lesker Company
1925 Route 51
Clairton, PA 15025-3681 USA

Phone: 412-387-9200
800-245-1656

FAX: 412-384-2745

© 1996 by the Kurt J. Lesker Company. All rights reserved.

Teflon and Viton are registered trademarks of DuPont Co.
VCR[®] is a registered trademark of Swagelok[®] Company

Table of Contents

- Table of Contents
- Package Contents 1
- Symbols Used in this Manual 2
- Safety Precautions 3
- Specifications 5
 - Controller 6
 - Sensor Tube 7
- Feature and Control Locations 8
- Typical Applications for the Series 947 CEP System 9
- About the Series 947 CEP Vacuum Sensor System 10
- Installing the Series 947 CEP System 11
 - CEP Sensor Installation 11
 - Location 11
 - Orientation 11
 - Contamination 11
 - Vacuum Connection 11
 - CEP Controller Installation 12
 - Controller Mounting 12
 - Connecting the Sensor to the Controller 13
 - AC Power Cord 14
 - Fuse Replacement 14
 - Accessory Connector 14
 - Relay Inductive Loads and Arc Suppression 15
- Operating the Series 947 CEP System 16
 - Reading Pressure 16
 - Sensor Adjustment 18
 - Calibrating for Zero and Atmosphere 18
 - Adjusting the Set Points 18
 - Venting to Atmosphere 19
 - Buffered Analog Output 19
 - Use with Computers 19

Leak Detection	19
Using the Series 947 CEP System with Other Gases	22
Nitrogen Equivalent Pressure	22
Calibrating for Other Gases	23
Maintaining the Series 947 CEP System	24
Troubleshooting and Service	24
Cleaning the Series 947 CEP Controller Front Panel	24
Cleaning the CEP Sensor	25
Testing the CEP Sensor	25
Preparing for Bakeout	26
Accessories	27
Notes	29
Notes	30
Appendix A: How the Series 947 CEP System Works	A.1
Theory of a Thermal Conductivity Sensor	A.1
Measurement Limits	A.1
The Series 947 CEP System Design Overview	A.2
Bridge Amplifier	A.2
Output	A.2
Set Point Relays	A.2
Comparator	A.2

Package Contents

Before unpacking your Series 947 Digital Convection Enhanced Pirani (CEP) Vacuum Sensor System, check all surfaces of the packing material for shipping damage.

Please be sure that your Series 947 CEP System package contains these items:

- ◆ 1 Series 947 CEP Controller
- ◆ 1 female, 9-pin, subminiature D (D-sub) *Accessory* connector
- ◆ 1 power cord
- ◆ 1 Series 947 Digital Convection Enhanced Pirani (CEP) Vacuum Sensor System User's Manual.

The Series 947 System's CEP Sensor and its connecting cable are sold separately. Please refer to page 26 for necessary ordering information.



If any items are missing from the package, call Kurt J. Lesker Customer Service at 1-412-387-9200 or 1-800-245-1656.

Inspect the Series 947 CEP System for visible evidence of damage. If it has been damaged in shipping, notify the carrier immediately. Keep all shipping materials and packaging for claim verification. Do **not** return the product to Kurt J. Lesker.

Symbols Used in this Manual

The first two symbols below, located on your Series 947 Controller and/or Sensor, identify critical safety concerns. They are used throughout this manual to further define the safety concerns associated with the product. The last two symbols identify other information in this manual that is essential to highlight or useful in achieving optimal performance from your Series 947 CEP System.



CAUTION: Risk of electrical shock.



CAUTION: Refer to manual.

Failure to heed message could result in personal injury or serious damage to the equipment or both.



Failure to heed message could result in damage to the equipment.



Information calling attention to important procedures, practices, or conditions.

Safety Precautions



Do not use the Series 947 CEP System's Sensor with explosive gas mixtures or gases that are combustible in air.

If the control circuit fails or an exothermic catalytic reaction occurs at the sensor platinum wire, the wire could ignite the gas mixture.



When using the Series 947 CEP System with gases other than air or nitrogen, avoid overpressure to prevent any possibility of explosion.

Since the Sensor is calibrated for air/nitrogen, the measured pressure of another gas will differ from its true pressure. Calibrations diverge widely at higher pressures. Since the different gases are not linearly related, a gas correction factor could lead to hazardous overpressure. Capacitance manometers and mechanical dial gauges are best suited for higher pressures. Refer to page 21 for use with other gases.

In a system which is filled from a pressurized source, install a safety relief valve or burst disc to safely limit pressure.



The Series 947 CEP Controller contains lethal voltages within the casing.

Avoid danger of electrical shock. Unplug the power cord before opening the casing.



Turn off power to the Controller before connecting or disconnecting a cable to the Sensor.

Connecting or disconnecting cables while the Controller is on may damage the Sensor.



Properly ground the Controller.

The Controller is grounded through the conductor of the power cord. If the protective ground connection is lost, all accessible conductive parts may pose a risk of electrical shock. Plug the cord into a properly grounded outlet only.

When applying a voltage or current to the ports on the rear of the panel, do not exceed manufacturer's specifications. Electrical shock may result.



Allow only qualified technicians to service the Series 947 CEP System.

Users should not remove covers, casings, or plug-in components. Injury may result. Any part replacement or internal adjustments must be performed by a qualified technician only.



To prevent damage to the Series 947 CEP Controller, use the correct line voltage.

Use the Controller with the specified line voltage only. Use a fuse of the correct type, voltage, and current rating. Only qualified personnel should change line voltage or fuse ratings if required.

Outside of the U.S., use only a detachable cord set having conductors with a cross-sectional area equal to or greater than 0.75 mm². Power cables should have agency approval, for example, VDE, Semko, or SEV.

The Series 947 CEP System and all its accessories must be used as instructed by Kurt J. Lesker, to ensure safe operation. Use or modification of the equipment in a manner not consistent with specifications may render the product's inherent protection useless.

Specifications

Controller

Measuring Range	1.0 x 10 ⁻³ to 1.0 x 10 ⁺³ Torr 1.0 to 1.0 x 10 ⁺⁶ microns 1.3 x 10 ⁻³ to 1.3 x 10 ⁺³ mbar 1.3 x 10 ⁻¹ to 1.3 x 10 ⁺⁵ Pa
Useful Set Point Range	2.0 x 10 ⁻³ to 9.9 x 10 ⁺² Torr 2.0 to 9.9 x 10 ⁺⁵ microns 2.7 x 10 ⁻³ to 1.3 x 10 ⁺³ mbar 2.7 x 10 ⁻¹ to 1.3 x 10 ⁺⁵ Pa
Resolution	1% of decade
Operating Temperature Range	5° to 40°C (41° to 104°F)
Storage Temperature Range	-10° to 55°C (14° to 131°F)
Relative Humidity	80% maximum for temperatures less than 31°C, decreasing linearly to 50% maximum at 40°C
Altitude	2000 m maximum
Insulation Coordination	Installation (Overvoltage) Category II, Pollution Degree 2
Mains Voltage	Fluctuations not to exceed ±10%
Number of Channels	1
Front Panel Controls	2 nonvolatile, independent relay set points; power on-off switch; zero adjustment; atmospheric adjustment
Relay Contact Rating	SPDT, 1 A @ 24 VAC/DC, resistive
Relay Response	150 msec maximum
Power Requirement	90 to 130 VAC, 50/60 Hz or 210 to 250 VAC, 50/60 Hz
Power Consumption	9 W

Output Voltage	0.33 to 5.63 VDC, buffered analog, 1 kW maximum output impedance
Fuse Rating, Size	T 0.16 A, Ø 5 mm x 20 mm for 90 to 130 VAC; T 0.063 A, Ø 5 mm x 20 mm for 210 to 250 VAC
Display	LED with 2 significant digits (1 leading) and 1 signed exponent; red, ³ / ₅ "-high, 7-segment digits; LED set point indicators; units shown in either Torr, mbar, Pascal or microns
Electronic Casing	Aluminum, anodized
Dimensions	3 ³ / ₄ " x 7" x 3 ³ / ₄ "
(W x D x H)	(96 mm x 178 mm x 96 mm)
Size	¼ DIN
Weight	2.2 lb (1.0 kg)
CE Certification	EMC Directive Low Voltage Directive

*The Controller meets CE mark requirements only if used with a Shielded Sensor.

Sensor Tube

Calibration Gas	Air/nitrogen
Installation Orientation	Horizontal <i>only</i>
Materials Exposed to Vacuum	304 stainless steel, platinum, glass, nickel
Repeatability	5% of indicated pressure @ T_{const}
Internal Volume	2.0 in. ³ (33.0 cm ³) maximum
Operating Temperature Range	0° to 50°C (32° to 122°F)
Maximum Bakeout Temperature	200°C (392°F), 100°C (212°F) shielded; without cable, connector/electronics subassembly, and Controller
Diameter	1.6 in. (41 mm)
Length	4.4 in. (112 mm)
Typical Weight (with KF 16 Flange)	0.5 lb (0.2 kg)
Vacuum Connection	KF 16 KF 25 1/8" NPT-M with 1/2" compression seal option 8 VCR®-F (1/2") 1 1/3" CF (non-rotatable) 2 3/4" CF (non-rotatable)

Design and/or specifications subject to change without notice.

Feature and Control Locations

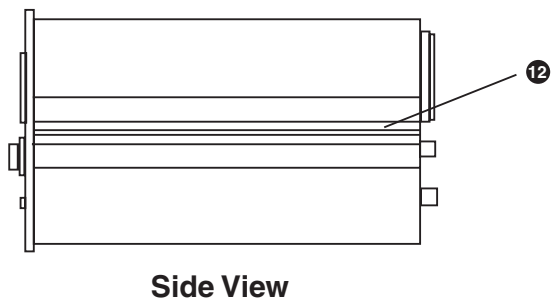
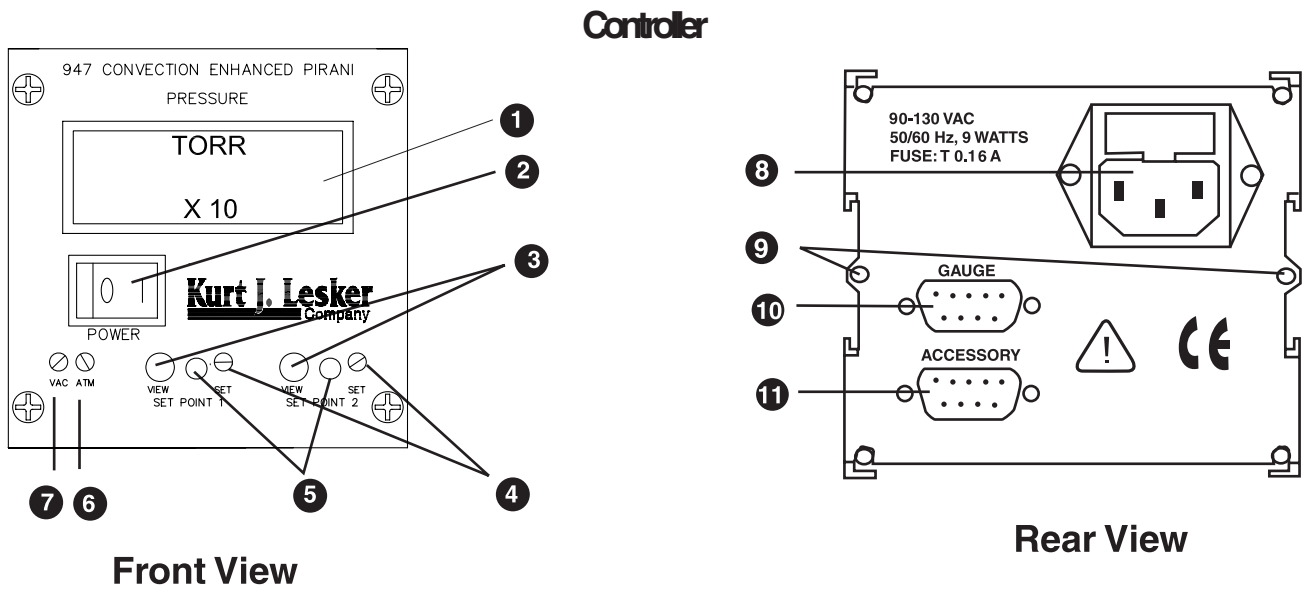

- ① Digital LED Display
- ② Power On-Off Rocker Switch
- ③ View Set Point Push-buttons
- ④ Set Point Adjustment Potentiometers
- ⑤ LED Set Point Indicators
- ⑥ Atmospheric Adjustment Potentiometer
- ⑦ Zero Adjustment Potentiometer
- ⑧ Power Cord Inlet w/ Fuse Holder
- ⑨ Panel Mounting Fastener Holes
- ⑩ Female, 9-pin Gauge Port
- ⑪ Male, 9-pin Accessory Port
- ⑫ Slots (for Optional Mounting Brackets)
- ⑬ Male, 9-pin Gauge Port
- ⑭ Sensor Vacuum Port

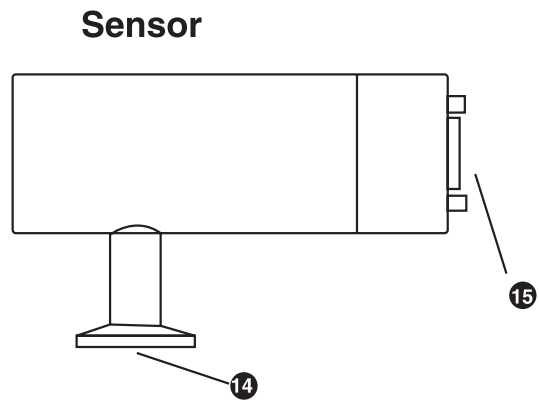

Typical Applications for the Series 947 CEP System



Measuring foreline and roughing pressures generated by mechanical vacuum pumps



Controlling valves and pumps to automate system pump down using the relay set points



Sensing abnormal pressure and taking appropriate security measures using the relay set points



Controlling system pressure using the analog output as input to an automatic pressure controller



Starting or stopping system processes using the relay set points



Measuring pressures of backfilled gases in the range of 10^{-3} to 10^{+3} Torr



Activating high vacuum sensors at the high end of their operating pressure range

About the SensaVac® Series 947 CEP Vacuum Sensor System

The Series 947 Convection Enhanced Pirani (CEP) System, together with its Sensor and connecting cable, provides accurate and reliable data for processes which need pressure control from 10^{-3} Torr to 10^{-3} Torr. It is low in cost and is easy to use.

The CEP Sensor is available with one of several standard fittings for vacuum connection. The Sensor connects to the Controller with a cable that has 9-pin D-sub connectors on either end, one male and one female. The Controller easily mounts into a ¼ DIN panel cutout or stands alone. All controls, even the power switch, are conveniently located on the front panel, and cable connections are hidden to the rear of the Controller.

The Series 947 CEP Controller is useful either as a small system controller or as a module in more sophisticated pressure control environments.

The Controller features two standard relay set points for process applications.

The pressure readout is a large, easy-to-read digital display. LEDs indicate the status of relay set points. Set points are independently adjusted using both a push-button and a potentiometer on the front panel.

The analog output and relay contacts are accessible from the *Accessory* port on the rear panel.

The Sensor can be located away from the Controller using a cable as long as 500 feet in length.



Installing the Series 947 CEP System

CEP Sensor Installation

Location

Locate the CEP Sensor where it can measure chamber or manifold pressure. Install it away from pumps and gas sources and where vibration is minimal to give the most representative values.

Orientation

The CEP Sensor can *only* be installed horizontally to work effectively in the convection region. Convection is an effective heat transfer process at pressures above 200 Torr of nitrogen. Install it in the direction indicated on the body of the Sensor.

The Sensor is factory calibrated with the vacuum port facing down. At atmosphere, the calibration may shift as much as 10% if the port is oriented otherwise. If it is necessary to do so, you should make a calibration adjustment (see **Calibrating for Zero and Atmosphere**, p.18).

Contamination

Locate and orient the CEP Sensor where contamination is least likely. For example, if the Sensor is installed directly above a roughing pump, oil vapor could contaminate the tube's filament wire and cause the calibration to shift.

Install the Sensor with the vacuum port facing down whenever possible to prevent particulates falling or liquids flowing into it. Using a screen or porous filter at the port is helpful. Try an seal and centering ring assembly with a screen.

Vacuum Connection

Standard vacuum interfaces for the CEP Sensor include:

- ◆ KF 16 flange
- ◆ KF 25 flange
- ◆ 8 VCR[®]-F (1/2") fitting
- ◆ 1 1/3" CF flange
- ◆ 2 3/4" CF flange
- ◆ 1/8" NPT-M fitting
- ◆ with 1/2" compression seal

To fit the Sensor with the 1/8" NPT, do not use the case for tightening. The Sensor's vacuum tubing has 9/16" hex flats for tightening. Wrap a layer of Teflon® tape on the threads of the tubing, in the direction of installation, to ensure a leak-free seal.

Instead of the NPT fitting, you may opt to use the 1/2" O-ring compression seal against the vacuum tubing above the thread, but the O-ring seal cannot be used for positive pressure applications.



Ensure a solid electrical connection between the Sensor and the grounded vacuum system to shield the tube element from external electromagnetic sources. In applications which the System will be exposed to large voltage fluctuations, install a centering ring with a screen, and then ground the screen and tubing.

CEP Controller Installation

Controller Mounting

The Series 947 CEP Controller is designed for either panel mounting or for stand-alone use. Regardless of the method you choose, assure adequate ventilation to the Controller with at least a 1/2 of an inch left open above and below the perforated panels.

An optional hardware kit is also available for mounting the Controller into a standard 1/4 DIN cutout in a panel up to 3/16-inch thick (see **Accessories**, p.26). A dimensioned illustration below shows the required cutout. Leave at least 3 inches of clearance behind the Controller to accommodate the connectors and cables.

Mount the Controller into the panel by slipping it through the cutout from the front. Slide the panel mounting brackets into the slots on either side of the Controller from the rear, and secure them with the thumbscrews provided.

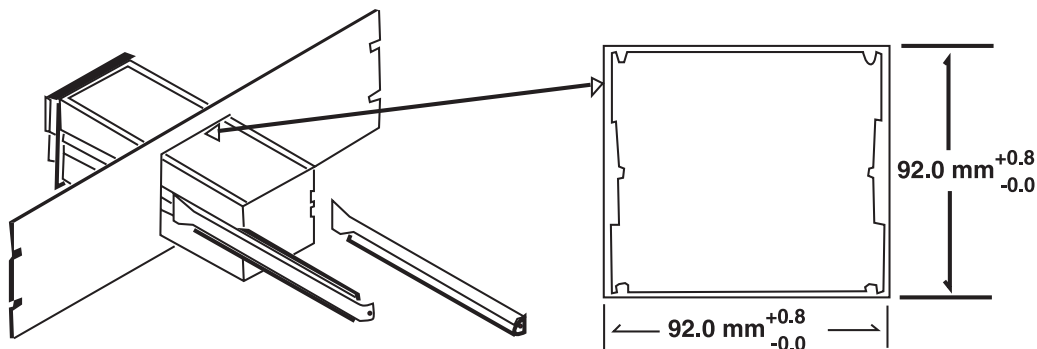

Panel mounting system with a 1/4 DIN cutout

Adhesive backed rubber feet for bench top use are provided with the mounting kit. Remove the adhesive backing from each foot and apply one to each corner of the aluminum bottom surface.

Connecting the Sensor to the Controller

A sensor cable with 9-pin D-sub connectors (see **Accessories**, p.26) is required for operation but is purchased separately from the CEP System.

When exerting excessive stress on the cable, use separate strain relief to prevent damage to the Sensor or Controller. Cables are available in standard lengths of 10, 25, 50, and 100 feet and in custom lengths up to 500 feet.

Connect the cable to the rear of the Controller at the *Gauge* port. Tighten the connector jackscrews into the mating screw locks to ensure proper electrical connection and to prevent stress on the connectors.



Turn off the Controller before connecting or disconnecting the cable from the Sensor or Controller.

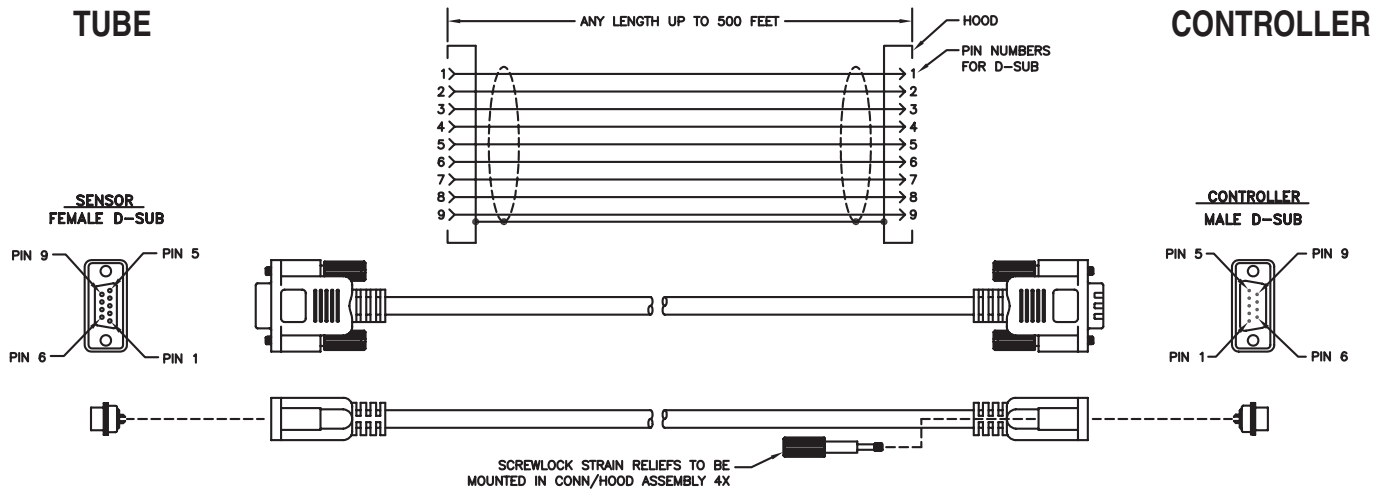

Customizing the sensor cable

In applications for which special cables are required, i.e., where the connection must be routed through restrictive barriers or through a conduit, customize the cable using the figure shown below. For short lengths, any cable wired straight through, e.g., pin 1 to pin 1, will suffice. For longer lengths, a cable with three twisted pairs and an overall shield is recommended. Use a D-sub connector with jackscrews for strain relief in all applications.

AC Power Cord

The Series 947 CEP System includes a standard, 120 VAC, 50/60 Hz power cord with a female IEC-320 connector.

If the available power source or connection is different, use only a detachable cord set with conductors that have a cross-sectional area equal to or greater than 0.75 mm². The power cable should be approved by a qualified agency such as VDE, Semko, or SEV.

Fuse Replacement

The Series 947 CEP System has a combined fuse holder and power outlet located on the rear panel of the Controller. Replace the fuse with the following steps.

1. Unplug the power cord from its outlet.
2. Snap out the fuse holder drawer.
3. Replace the fuse(s) with one of the following time-lag fuses:
 - ◆ T 0.16 A (Ø 5 mm x 20 mm) – 90 to 130 VAC
 - ◆ T 0.063 A (Ø 5 mm x 20 mm) – 210 to 250 VAC.
4. Close and secure the fuse holder drawer.

Accessory Connector

Relay set point contacts and the analog output voltage can be accessed from the *Accessory* port on the rear panel of the Controller. A connector kit to mate to the port is provided. The figure and chart below identify the pin functions of the *Accessory* port.

Pin	Description
1	Set point relay 1 - normally closed contact
2	Set point relay 1 - normally open contact
3	Set point relay 2 - common
4	Not used
5	Analog output voltage (+)
6	Set point relay 1 - common
7	Set point relay 2 - normally closed contact
8	Set point relay 2 - normally open contact
9	Analog output voltage (-)

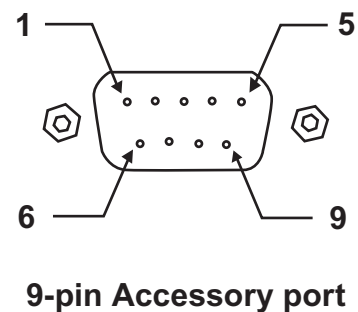



Do not inadvertently short circuit the set point relay terminals to the analog output voltage.

Relay Inductive Loads and Arc Suppression

If the set point relay is used to switch inductive loads, e.g. solenoids, relays, transformers, etc., the arcing of the relay contacts may interfere with Controller operation or reduce relay contact life. Therefore an arc suppression network, shown schematically below, is recommended. The values of the capacitance C and the resistance R are calculated by the equations,

$$C = I^2 / (1 \times 10^7) \text{ and } R = E / I^a$$

where,

C is in farads

R is in ohms

I is DC or AC_{peak} load current in amperes

E is DC or AC_{peak} source voltage in volts

$$a = 1 + (50/E).$$

Note that,

$$R_{min} = 0.5 \text{ W} \text{ and } C_{min} = 1.0 \times 10^{-9} \text{ F}.$$

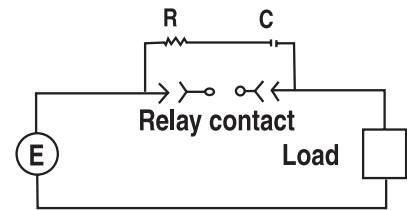

Relay arc suppression network

Operating the Series 947 CEP System

Reading Pressure



The Sensor must be connected to the Controller before turning on the unit.

Turn the power on to display pressure or to operate the set point relays. The table below shows the Series 947 CEP System's voltage output as a function of pressure for nitrogen, argon, and helium, and the graph on the next page gives the same information.

Since Pirani systems are gas dependent and the Series 947 CEP System is calibrated for air/nitrogen, it reads in *nitrogen equivalent pressure* for argon, helium, or any other gas. The table and graph do not give true pressure of gases other than nitrogen. Refer to page 21, **Using the Series 947 CEP System with Other Gases**, to determine true pressure.

Torr	Pascal	Voltage			Torr	Pascal	Voltage		
		Nitrogen	Argon	Helium			Nitrogen	Argon	Helium
1.0E-03	1.3E-01	0.333	0.331	0.332	1.0E+00	1.3E+02	2.384	1.932	2.332
2.5E-03	3.3E-01	0.350	0.341	0.345	2.0E+00	2.7E+02	3.023	2.461	3.208
5.0E-03	6.7E-01	0.376	0.358	0.366	3.0E+00	4.0E+02	3.392	2.771	3.846
7.5E-03	1.0E+00	0.400	0.374	0.386	4.0E+00	5.3E+02	3.637	2.979	4.357
1.0E-02	1.3E+00	0.423	0.389	0.404	5.0E+00	6.7E+02	3.813	3.129	4.786
2.0E-02	2.7E+00	0.503	0.444	0.471	6.0E+00	8.0E+02	3.947	3.243	5.156
3.0E-02	4.0E+00	0.571	0.493	0.529	7.0E+00	9.3E+02	4.051	3.332	5.481
4.0E-02	5.3E+00	0.631	0.538	0.581	8.0E+00	1.1E+03	4.136	3.405	5.771
5.0E-02	6.7E+00	0.686	0.578	0.628	9.0E+00	1.2E+03	4.205	3.465	6.033
6.0E-02	8.0E+00	0.736	0.616	0.672	1.0E+01	1.3E+03	4.263	3.515	6.270
7.0E-02	9.3E+00	0.783	0.652	0.713	2.0E+01	2.7E+03	4.561	3.772	7.858
8.0E-02	1.1E+01	0.827	0.685	0.751	3.0E+01	4.0E+03	4.675	3.871	8.745
9.0E-02	1.2E+01	0.868	0.717	0.788	4.0E+01	5.3E+03	4.736	3.924	9.322
1.0E-01	1.3E+01	0.907	0.747	0.823	5.0E+01	6.7E+03	4.774	3.957	9.730
2.0E-01	2.7E+01	1.221	0.993	1.110	7.5E+01	1.0E+04	4.826	4.001	10.372
3.0E-01	4.0E+01	1.456	1.179	1.334	1.0E+02	1.3E+04	4.852	4.023	10.747
4.0E-01	5.3E+01	1.647	1.332	1.523	2.0E+02	2.7E+04	4.924	4.087	
5.0E-01	6.7E+01	1.809	1.463	1.689	3.0E+02	4.0E+04	5.017	4.174	
6.0E-01	8.0E+01	1.951	1.578	1.838	4.0E+02	5.3E+04	5.149	4.296	
7.0E-01	9.3E+01	2.076	1.680	1.975	5.0E+02	6.7E+04	5.266	4.391	
8.0E-01	1.1E+02	2.189	1.772	2.102	7.5E+02	1.0E+05	5.479	4.563	
9.0E-01	1.2E+02	2.291	1.855	2.221	1.0E+03	1.3E+05	5.629	4.685	

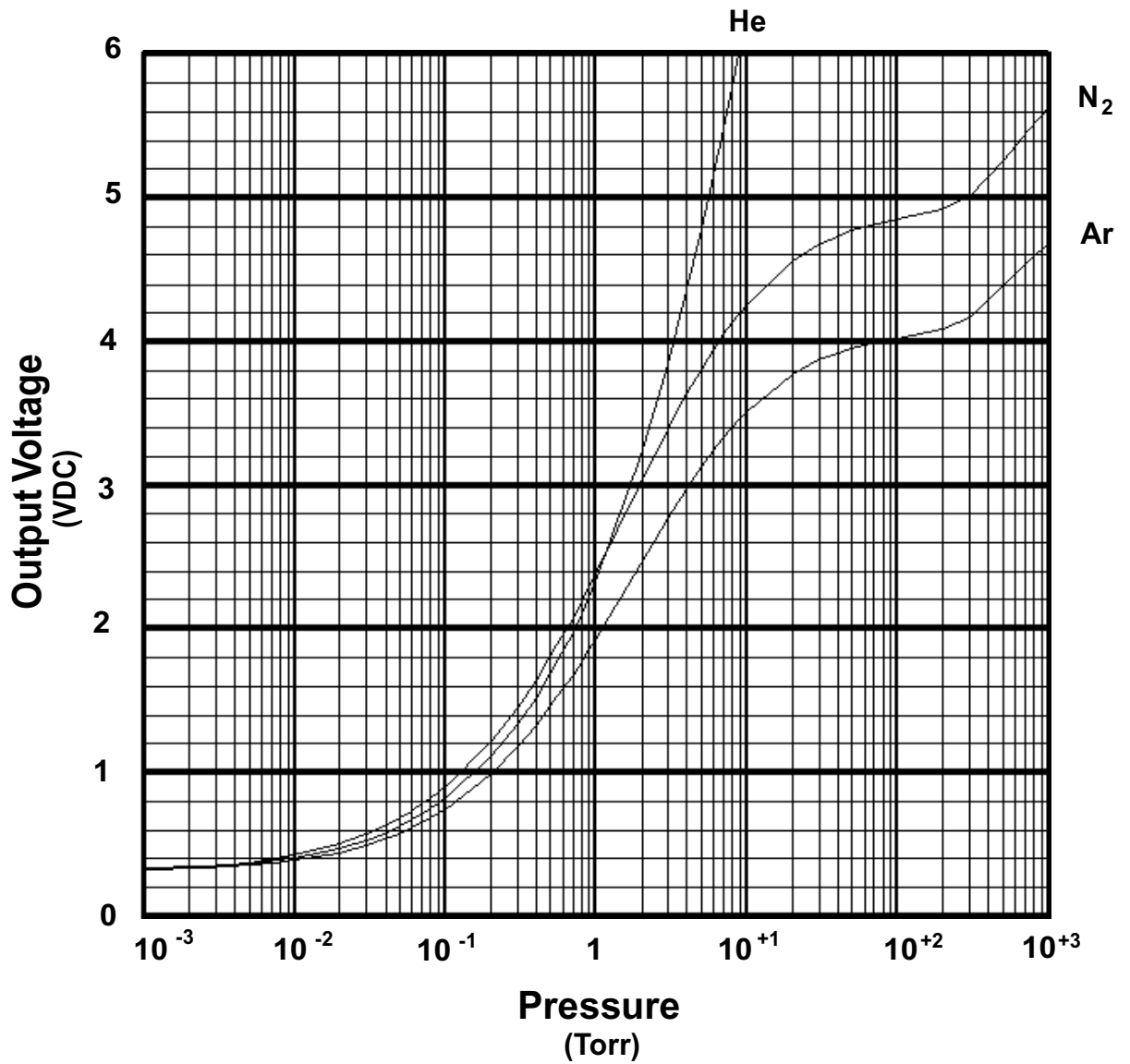

At pressures above 1000 Torr, the Series 947 System's upper measuring limit, the Controller display will show . +9.



When using the graph, remember that the pressure scale is logarithmic, and the voltage scale is linear. Equal increments of distance along the pressure scale do not correspond to equal pressure changes.

Sensor Adjustment

Series 947 CEP Controllers and their Sensors are factory calibrated. However, instances in which user-calibration will be required are:

 After installation on your system, the Controller and Sensor need to be calibrated as a unit. They are not factory calibrated as a unit. From Sensor to Sensor, readings may differ. Calibration at higher pressures may also differ if the Sensor is not oriented with the port facing down.

 If the Sensor becomes contaminated with process chemicals or pump oil, the calibration may shift.

Calibrating for Zero and Atmosphere

Vacuum and atmosphere adjustment potentiometers are located on the front panel as shown below. The two adjustments can be made independently, but because of some interaction between them, we recommend making the adjustments in the order below.

 **For best results, let the CEP System remain at the calibration pressure for at least 15 minutes before adjusting the potentiometers.**

1. To adjust for atmosphere, an accurate high pressure reference sensor will be required. With the reference sensor at local atmospheric pressure (between 500 and 1000 Torr), adjust the *Atm* potentiometer until the display indicates the correct pressure.

2. To adjust for vacuum, the CEP Sensor needs to be on a vacuum system pumped down to less than 1.0×10^{-5} Torr. At this pressure, the Series 947 Controller display should read 0.0 -3 Torr (0.0 +0 microns, 0.0 -3 mbar, or 0.0 -1 Pa). If only 3 is shown, turn the *Vac* potentiometer clockwise until 0.0 -3 is displayed. If the reading is 1.0 -3 or higher, turn the *Vac* potentiometer counterclockwise until 0.0 -3 is displayed. For best results, adjust the potentiometer closer to 1.0 -3 rather than 0.0 -3.

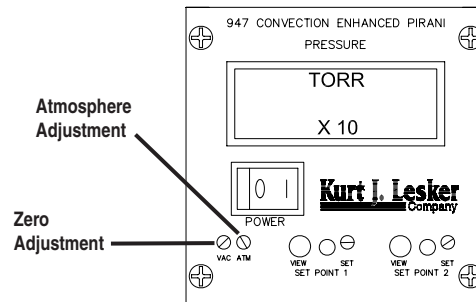

Adjusting the Set Points

To adjust a set point to open or close the relay contact at a particular pressure, press the view button for the desired set point on the front panel. Keeping this button depressed, use a small screwdriver to adjust the corresponding potentiometer until the reading coincides with the desired set point pressure.

When an LED is on, the measured pressure is below the set point value, the normally open relay contact is closed, and the normally closed contact is

open. When an LED is off, the measured pressure is above the set point value, the normally open relay contact is open, and the normally closed contact is closed.

Venting to Atmosphere

The CEP Sensor senses pressure by measuring heat loss from a heated fine wire. Sudden venting at its port can greatly stress the Sensor physically.



To avoid damage to the Sensor, vent the vacuum system to atmosphere *before* removing it.

Buffered Analog Output

The Series 947 CEP Controller's analog output voltage is buffered. The temperature compensated signal from the Sensor is buffered by a unity gain amplifier, then connected to the *Accessory* port. This signal has an amplitude of approximately 0.33 V in vacuum to 5.5 V at atmosphere and follows the voltage-versus-pressure curve shown on page 17. Since this signal is not digitally processed, the Series 947 CEP System is suitable for use in applications in which measurement speed is important.

Use with Computers

The Series 947 CEP System is designed to operate in highly automated systems (especially those controlled by digital computers), as well as in manual systems. It is compatible with a wide variety of computers, interfaces, and software.

In order to take full advantage of the System's capabilities, an analog-to-digital (A/D) converter should be used with an input voltage span of 0 to 6 V. The A/D conversion rate should be at least 6 Hz (150 msec conversion time). A resolution of 12 bits is needed, corresponding to 1.46 mV per bit. The A/D converter should have a differential input to prevent ground currents from affecting the measurements.

Leak Detection

Its inherent sensitivity to gas type makes the Series 947 CEP System useful for detecting leaks, at rates greater than 10^{-4} std cc/sec of helium, in foreline and roughing systems. It is a useful complement to a mass spectrometer leak detector, which locates smaller leaks.

- 1) Pump your vacuum system to a base pressure.
- 2) Slowly and methodically probe with a small amount of gas.



Flooding the leak or moving quickly past the leak can confuse the search since system time lags may be significant.

- 3) Note the pressure reading.

The pressure will either rise or fall, depending upon the thermal conductivity of the probe gas relative to the system gas. The largest change in value indicates the probe gas is nearest the leak location.

4) Repeat the test to confirm.

As with any leak testing, many factors can influence the sensitivity of the test. Explained in further detail below, these include chamber volume; system pressure; probe gas; type of vacuum pump; location of the Sensor, leak, and the pump; and others such as pumping speed and size of tubing in the system.



Minimize the chamber volume to reduce the search area and increase the efficiency of the test.



Sensitivity to gas leaks is also pressure dependent due to the complex nature of heat transfer at pressures above 10^{-1} Torr and the presence of significant radiation and end losses below 10^{-3} Torr. Leak test sensitivity is generally greater for lower system pressures.



The Series 947 CEP System is sensitive to any leak probe gas lighter or heavier than the system gas, however, for optimal sensitivity, select a probe gas with the largest difference between its molecular weight and that of the system gas. Lighter gases increase thermal energy transfer while heavier gases reduce it. Helium or argon gas is suitable to probe a system pumping air or nitrogen.



The type of vacuum pump used can also affect the accuracy of the leak test. For moderate size leaks, pump down the system with a high vacuum pump such as a diffusion or turbo pump if possible (ion and cryo pumps are not recommended). Leak testing can be done with a mechanical pump, however, cyclical variations in pressure may result due to rotation of the vanes. This shows up as a large background noise signal, possibly masking the leak signal.



Place the pump away from the suspected leak source and place the Sensor between the leak and the pump to reduce the Sensor response time. Vacuum tubing between the suspected leak and the Pirani Sensor should be as short and wide as possible to shorten the time required for the probe gas to reach the tubing.

If the above detection method does not locate a leak, unexpected high pressures may be caused by a virtual leak, i.e., outgassing of a system component. You can locate outgassing parts, or "virtual leaks", as well as true gas leaks, using the *rate-of-pressure-rise* method.

- 1) With the Controller on, pump down the system to a base pressure.
- 2) Close a valve to isolate the pump.
- 3) Measure the rise in pressure over a time interval. A very fast rise indicates a leak.
- 4) Repeat this procedure as often as necessary.

Using the Series 947 CEP System with Other Gases



Before using the Series 947 CEP System to measure pressure of gases other than air or nitrogen, you should read and understand this section. To answer further questions, contact Kurt J. Lesker Company at 1-412-387-9200 or 1-800-245-1656.

The Series 947 CEP System is designed to give voltage output for air/nitrogen according to the graph on page 17 or the table on page 16. If the CEP System is used to read pressure of gases with poorer heat transfer properties than nitrogen, the true system pressure may be much higher than indicated. *This reading error could lead to dangerous overpressure.*



A system which is backfilled from a pressurized gas source should contain a safety device, such as a burst disc.

Nitrogen Equivalent Pressure

The thermal loss from a heated sensor element is a function of the transporting gas (see p. A.1, **Theory of a Thermal Conductivity Sensor.**) Since the Series 947 CEP System's Sensor is such a gauge, the voltage output depends upon the gas measured.

When used with gases other than nitrogen (N_2), the System reads in *nitrogen equivalent pressure*. For example, when the Sensor is set up to read pressure for N_2 but is used with the gases helium (He) or argon (Ar), the data for He and Ar in the graph on page 17 are used to convert *nitrogen equivalent pressure* to true pressure.

1. Locate the indicated pressure on the pressure axis of the graph on page 17 (as shown in the example to the right). Locate the point at which a vertical line from this point intercepts the curve for N_2 .
2. Locate the point at which a horizontal line from the point on the N_2 curve intercepts the He or Ar curve.
3. Locate the point at which a vertical line from the He or Ar curve intercepts the pressure axis. This point corresponds to the true pressure for He or Ar.

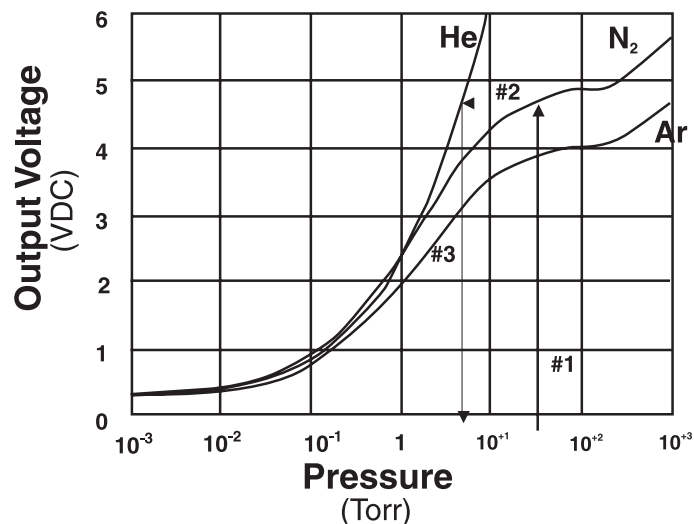



The *nitrogen equivalent pressures* of some gases can exceed the measuring capabilities of the Series 947 CEP Controller. For example, a true pressure of 20.0 Torr of helium is equivalent to a *nitrogen equivalent pressure* of several 1000 Torr. The Series 947 CEP Controller is not capable of measuring this pressure of helium.

Calibrating for Other Gases

To determine the voltage/pressure relationship for gases which are not shown in the graph or table, you might need to calibrate the Series 947 CEP System with this gas. This calibration requires a gas-independent sensor, such as a capacitance manometer, to act as a standard. A curve like that of page 17 can then be generated and used as described above.



The Series 947 CEP Controller is *not* intended to be calibrated for direct pressure readings of gases other than air or nitrogen. The calibration is intended *only* to match the air/nitrogen curve of the Controller to the characteristic of a particular sensor.

Maintaining the Series 947 CEP System

Troubleshooting and Service

The Series 947 CEP Controller is designed to be maintenance-free under normal operation. If a problem should occur, the following chart lists symptoms, possible causes, and their remedies. With this guide, you should be able to diagnose some problems and correct them. Those which fall outside the scope of this chart are generally not serviceable by the user, and the unit should be returned to Kurt J. Lesker for repair.

Cleaning the Series 947 CEP Controller Front Panel

The front panel of the CEP Controller is designed to resist many laboratory solvents. The casing can be cleaned with water or alcohol.



Do not use acetone on the front panel.

Troubleshooting Chart

Symptom	Possible Cause	Remedy
Pressure readings are too high or too low.	<ol style="list-style-type: none"> 1. Contaminated Sensor. 2. Gas other than air is used. 3. Controller incorrectly calibrated. 	<ol style="list-style-type: none"> 1. Test and replace if necessary. Refer to page 24. 2. Refer to page 21. 3. Refer to page 18.
No analog output voltage, and no display.	<ol style="list-style-type: none"> 1. Power supply turned off. 2. Fuse is blown. 3. Defective PC board. 	<ol style="list-style-type: none"> 1. Turn power on. 2. Replace fuse. 3. Return to Kurt J. Lesker for repair.
No analog output voltage, but set points functional.	<ol style="list-style-type: none"> 1. Analog output shorted to ground. 2. <i>Accessory</i> or <i>Gauge</i> connector disconnected. 3. Defective PC board. 	<ol style="list-style-type: none"> 1. Check cable connections at <i>Accessory</i> port. 2. Connect cable to its port. 3. Return to Kurt J. Lesker for repair.
Set point relay will not operate.	<ol style="list-style-type: none"> 1. Set point voltage incorrectly set. 2. Broken or shorted Sensor filament. 3. Defective PC board. 	<ol style="list-style-type: none"> 1. Check set point. 2. Test and replace if necessary. Refer to page 24. 3. Return to Kurt J. Lesker for repair.

Cleaning the CEP Sensor

Roughing pump oils and other fluids condensing or decomposing on the heated filament can contaminate the Sensor. This changes the emissivity of the filament, which in turn can cause the calibration to change, especially at low pressure.



It is not advisable to clean the Sensor. Trying to clean it may either deform or break the filament, and the deformed filament would then cause additional error from a shift in the Sensor's output.

Replace the Sensor if it becomes contaminated (see **Accessories**, p. 26).

Testing the CEP Sensor

Make sure the Controller is turned off and the Sensor is disconnected from the cable beforehand.

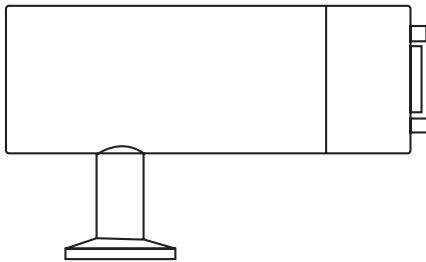

Sensor side view

1. With a #1 Phillips head screwdriver, remove the two screws to separate the connector/electronics subassembly from the end of the Sensor as shown to the right.
2. Check the resistance on the Sensor's PC board for the pins listed in the first column below. Test the Sensor with an ohmmeter with less than 5 mA of current. The resistance readings of a normal Sensor measured at atmospheric pressure and at room temperature (20°C) are listed in the middle column. If the condition shown in the right column exists, the Sensor should be replaced.

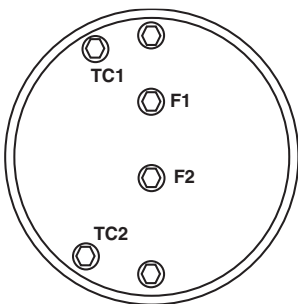

Sensor PC board

Check	Resistance (Ω)	If Reading Is
F1 to F2	20	Higher, filament is broken or burned out.
F1 to Sensor port F2 to Sensor port	20×10^6	Lower, Sensor is damaged or contaminated.
TC1 to TC2	27	Higher, temperature compensation winding is broken.
TC1 to Sensor port TC2 to Sensor port	20×10^6	Lower, temperature compensation winding is shorted to Sensor body.

Preparing for Bakeout

Remove the cable from the CEP Sensor. As shown on the previous page, use a #1 Phillips head screwdriver to remove the two screws at the end of the connector/electronics subassembly to separate it from the Sensor. The standard CEP Sensor can be baked up to 200°C and the Shielded CEP Sensor can be baked up to 100°C.

Accessories

	Part #
Sensor 945 output Connector kit	K8103
Cables for the CEP Sensor	
10 ft (3.0 m)	K31706S
25 ft (7.6 m)	K31707S
50 ft (15.2 m)	K31708S
CEP Sensors, Shielded	
KF 16	K31710S
KF 25	K31727S
1/8" NPT-M with 1/2" Compression Seal Option	K31711S
8 VCR®-F (1/2")	K31712S
1 1/3" CF (Non-rotatable)	K31713S
2 3/4" CF (Non-rotatable)	K31714S
4 VCR®-F	K31729S
Mounting Hardware Kit	K5021
Power Cord, 115 VAC	103150001
Series 947 Digital Convection Enhanced Pirani (CEP) Vacuum Sensor System User's Manual	100014431

Please call Kurt J. Lesker Customer Service Department at 1-412-387-9200 or 1-800-245-1656 to order any of these accessories or to receive catalogs for other Kurt J. Lesker products.



Notes

Notes



Notes

Appendix A: How the Series 947 CEP System Works

The Series 947 CEP System is a heat-loss manometer which infers the pressure of a gas by measuring thermal loss from a heated wire.

Theory of a Thermal Conductivity Sensor

A hot wire suspended from supports in a partial vacuum loses thermal energy in three ways:

- ◆ **gas transport, which is pressure dependent,**
- ◆ **end loss to the supports, and**
- ◆ **radiation to surrounding surfaces.**

Convection enhanced Pirani and thermocouple sensors use pressure-dependent gas transport from a hot wire to measure pressure. Because end loss and radiation are constant for a wire at constant temperature, they provide a masking signal which largely determines the low pressure limit of the sensor. Optimizing parameters of the wire length and diameter, thermal emissivity, thermal conductivity, and wire temperature can control but not eliminate these terms.

A convection enhanced Pirani sensor may be operated at constant current, voltage, or resistance (equivalent to temperature) at the sensor wire. The Series 947 System's CEP Sensor is operated at constant temperature to increase high pressure sensitivity. At constant current or voltage, the wire temperature at high pressure is much less than the temperature value at vacuum, reducing the high pressure sensitivity.

Measurement Limits

At 10^{-3} Torr, the sum of end and radiation losses is about 10 times the energy lost to the gas through conduction. This determines the practical lower limit for thermal conductivity sensors.

At pressures between 20 to 200 Torr, the gas acts as an insulation layer around the filament, which reduces the sensitivity of the sensor.

At pressures above 200 Torr, convection currents contribute to energy transport from the filament, increasing sensitivity at these pressures. In the case of the Series 947 System's CEP Sensor, the upper measurement limit is determined by the amount of energy the electronics is able to provide to the filament.

The Series 947 CEP System Design Overview

This section is intended to give the reader an overview of the internal workings of the Series 947 CEP System. This manual does not provide sufficient detail for advanced levels of troubleshooting. Refer to the block diagram while reading this section.

Bridge Amplifier

The Sensor uses a wire as one arm of a balanced Wheatstone bridge. The bridge amplifier maintains the wire at a constant temperature. Thus, the bridge driving voltage from the amplifier is related to the pressure in the Sensor.

This voltage is buffered by an op amp and then fed to the analog output, the Controller's digital display, and the comparator circuit.

Output

The analog output is driven by an op amp. Although it has a fairly low output impedance, it is best to measure the analog output signal with an instrument having at least 1 M Ω of input impedance.

Set Point Relays

A reference voltage and op amp form a precision adjustable reference that is fed to the comparator circuit. A potentiometer can be adjusted to the proper voltage to trigger the set point relay at the desired pressure.

Comparator

An analog comparator circuit compares the voltage from the buffer amplifier (pressure signal) to the set point. When the pressure signal falls below the adjusted reference voltage, a transistor turns on, which energizes the set point relay. A resistor provides a feedback path around the op amp, which increases the set point voltage by approximately 10 mV. This hysteresis provides stable operation even though some noise may be present on the buffered output signal.

