

Kurt J. Lesker
Company

UHV VIEWPORTS

OPTICAL & LASER

BIOTECHNOLOGY PHARMACEUTICAL DISPLAY TECHNOLOGIES OLED/PLED NANOTECHNOLOGY

MEMS NIGHT VISION AEROSPACE SEMICONDUCTOR SUPERCONDUCTOR OPTICAL & WEB COAT



REFRIGERATION LASER TECHNOLOGY DATA STORAGE MASS SPECTROMETRY THIN FILM PHARMA

AUTOMOTIVE LIGHTING SURFACE ANALYSIS R&D HIGH ENERGY PHYSICS HEAT TREATING DISP

For More Choices - Think Lesker!

True UHV – Laser Transmission Series Viewports

Common Specifications:

Leak Test – 2×10^{-10} cc/sec
304 Stainless Steel Flange
Parallelism – < 3 Arc Seconds
Flatness – $\lambda/4$ @ 632nm Transmitted Wavefront
Surface Finish – 20/10 Scratch-Dig
Max Bakeout – 200°C
Window Material – Corning HPFS 7980 Fused Silica
Homogeneity Grade – A
Inclusion Class – 0
Coating – $R < 0.25\%$ Per Surface, Transmission $> 99.5\%$

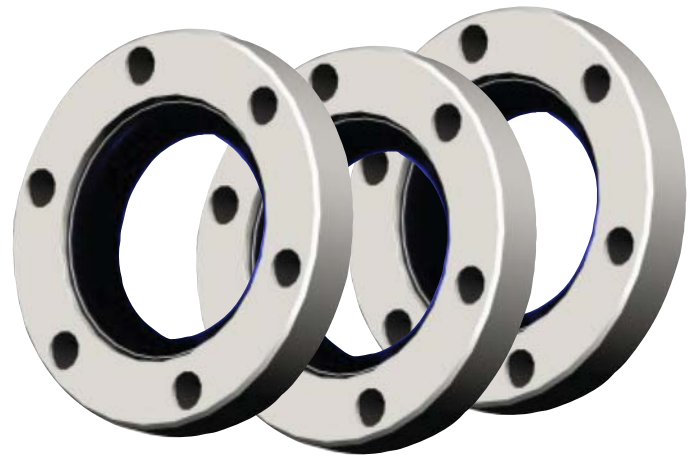

Part Number	Laser Style	Threshold (10ns pulse)	Coating (Both Sides)	Transmission Grade
VPZL-275LYAG	1064nm YAG	10J/cm ²	V-Coat 1064nm	IR Grade
VPZL-275LDIO	780nm Diode	10J/cm ²	V-Coat 780nm	DUV Grade
VPZL-275LARF	193nm ArF Excimer	1J/cm ²	V-Coat 193nm	Excimer Grade
VPZL-275LKRF	248nm KrF Excimer	1J/cm ²	V-Coat 248nm	DUV Grade

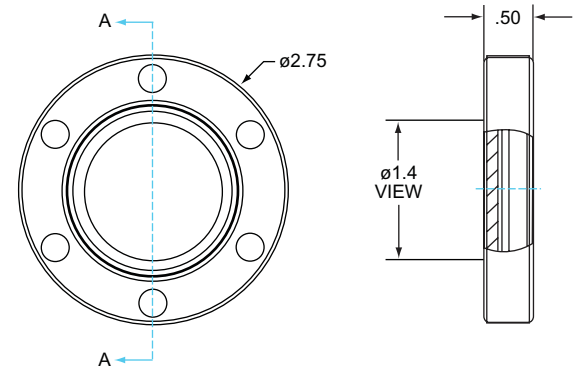

True UHV – Optical Series Exotic Glass Viewports

Common Specifications:

Leak Test – 2×10^{-10} cc/sec
304 Stainless Steel Flange
Parallelism – 3 Arcminutes
Flatness – $\lambda/4$



Part Number	Window Material	Surface Finish	Max Bakeout	Coating
VPZL-275UZ	Zinc Selenide	40-20	200C	N/A
VPZL-275UM	Magnesium Fluoride	20-10	200C	N/A
VPZL-275UC	Calcium Fluoride	20-10	200C	N/A
VPZL-275UZC	Zinc Selenide	40-20	150C	8-12 Microns, $R(\text{avg}) < 0.5\%$ Per Surface (Coated Both Sides)

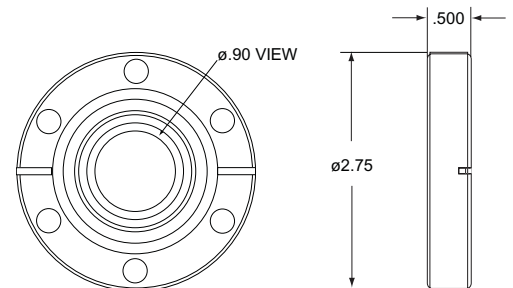

Kurt J. Lesker
Company

www.lesker.com 1.800.245.1656 sales@lesker.com