

STANDARD CHAMBERS

Box & Cylindrical



Features

- 304 Stainless Steel
- 6061-T6 Aluminum hinged door, o-ring sealed with rectangular viewport
- O-ring sealed box chambers are capable of reaching High Vacuum (HV) levels

Options

- ISO, QF, or CF style ports can be added
- Water-cooling for high-temperature applications
- Standard pumping and gauging packages
- Standard frames—carbon steel and extruded aluminum

Downloads & Ordering

- All of our standard chamber designs may be purchased through our website
- Dimensional 2D Drawings in Adobe PDF format available
- Engineering Files in DXF (2D) and STP (3D) formats available
- Interactive 3D Models using 3D PDF format

Online Product Configurator

- Build your own custom product using standard envelopes
- Produce a 3D viewable PDF file and a downloadable STP file
- Modify your design as many times as you like
- Add-to-cart feature for instant pricing

www.lesker.com

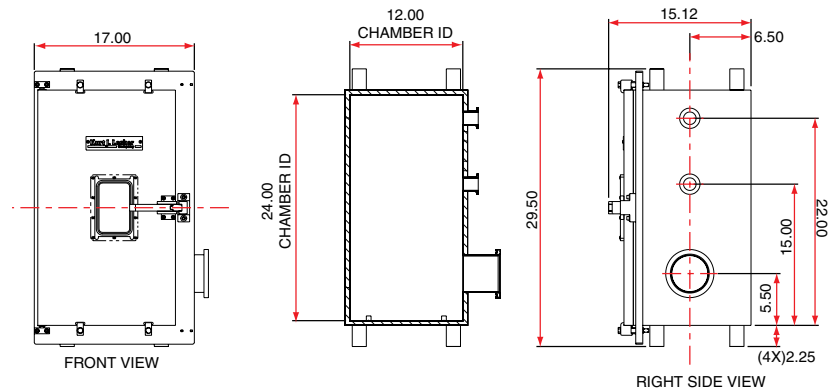

BX1224S
Dimensions Shown

Specifications: Box Chamber

	BX1212S	BX1224S	BX1616S	BX2424S	BX2430S	BX3030S	BX3648S
Inside Width	12"	12"	16"	24"	24"	30"	36"
Inside Depth	12"	12"	16"	24"	24"	30"	36"
Inside Height	12"	24"	16"	24"	30"	30"	48"
Body Material	304 SS	304 SS	304 SS	304 SS	304 SS	304 SS	304 SS
Door Material	6061 Al	6061 Al	6061 Al	6061 Al	6061 Al	6061 Al	6061 Al
Ports	(1) QF40, (1) QF100-SWK	(2) QF40, (1) QF100-SWK	(2) QF40, (1) QF100-SWK	(2) QF40, (1) QF100-SWK	(4) QF40, (1) QF160-SWK	(4) QF40, (1) QF100-SWK & (1) QF160-SWK	(4) QF40, (1) QF100-SWK & (1) QF320-SWK
Approx. Weight	172 lbs.	266 lbs.	253 lbs.	670 lbs.	775 lbs.	1,471 lbs.	2,690 lbs.

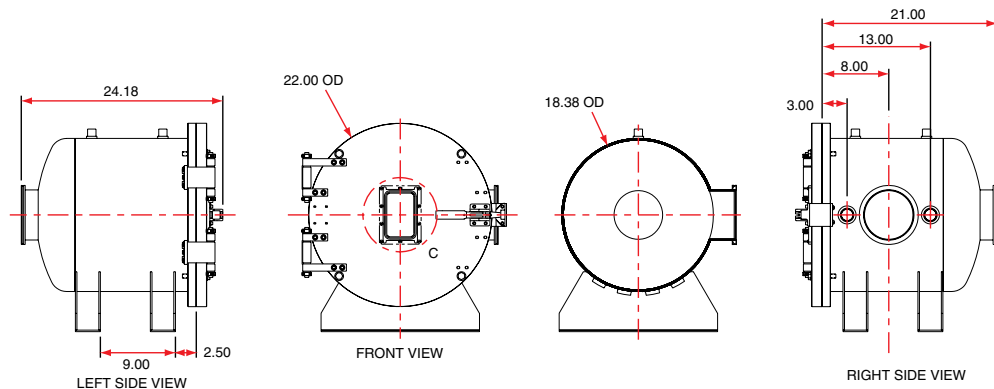

CA1821S
Dimensions Shown

Specifications: Cylindrical Chamber

	CA1821S	CA1830S	CA2430S	CA3030S	CA3050S
Chamber O.D.	18.38	18.38	24	30	30
Door O.D.	22	22	28	34	34
Length	24.18	33.19	33.19	33.41	53.41
Ports	(2) QF40, (2) QF160-SWK	(2) QF40, (1) QF160-SWK, (1) QF250-SWK	(2) QF40, (1) QF160-SWK, (1) QF250-SWK	(2) QF40, (1) QF160-SWK, (1) QF250-SWK	(2) QF40, (1) QF160-SWK, (1) QF250-SWK

Kurt J. Lesker Company (KJLC®) specifications and/or test data may not be copied, reproduced or referenced without express written permission of KJLC.

Kurt J. Lesker
Company

www.lesker.com

Kurt J. Lesker Company
United States
412.387.9200
800.245.1656
salesus@lesker.com

Kurt J. Lesker Canada Inc.
Canada
416.588.2610
800.465.2476
salescan@lesker.com

Kurt J. Lesker Company Ltd.
Europe
+44 (0) 1424 458100
saleseu@lesker.com

Kurt Lesker (Shanghai) Trading Company
科特·莱思科(上海)商贸有限公司
Asia
+86 21 50115900
saleschina@lesker.com

