



HiPace 60 P

Turbopump

Operating Instructions

Table of contents

1	About this manual	3
	1.1 Validity	3
	1.2 Conventions	3
2	Safety	5
	2.1 Safety precautions	5
	2.2 Protective equipment	6
	2.3 Proper use	7
	2.4 Improper use	7
3	Transport and storage	8
	3.1 Transport	8
	3.2 Storage	8
4	Product description	9
	4.1 Product identification	9
	4.2 Function	10
	4.3 Range of application	11
5	Installation	12
	5.1 Set-up	12
	5.2 Preparatory work	12
	5.3 Assembly	12
	5.4 Connections to the turbopump	15
6	Operation	21
	6.1 Commissioning	21
	6.2 Operation modes	21
	6.3 Function description	21
	6.4 Monitoring of the operation conditions	22
	6.5 Switching off and venting	23
7	Maintenance / replacement	24
	7.1 Maintenance intervals and responsibilities	24
	7.2 Replacing the operating fluid reservoir	24
	7.3 Replacing the electronic drive unit	26
8	Decommissioning	27
	8.1 Shutting down for longer periods	27
	8.2 Re-starting	27
	8.3 Disposal	27
9	Malfunctions	28
	9.1 Rectifying malfunctions	28
10	Service	29
11	Spare parts HiPace 60 P	30
12	Accessories	31
13	Technical data and dimensions	32
	13.1 General	32
	13.2 Technical data	32
	13.3 Dimensions	33
	Declaration of conformity	34

1 About this manual

1.1 Validity

This operating manual is for customers of Pfeiffer Vacuum. It describes the functioning of the designated product and provides the most important information for safe use of the unit. The description follows applicable EU guidelines. All information provided in this operating manual refers to the current state of the product's development. The documentation remains valid as long as the customer does not make any changes to the product.

Up-to-date operating instructions can also be downloaded from www.pfeiffer-vacuum.com.

Applicable documents

HiPace 60 P	Operating instructions
Operating instructions "Electronic drive unit TC 110"	PT 0204 BN*
Declaration of conformity	Part of this document

*also available via www.pfeiffer-vacuum.com

1.2 Conventions

Safety instructions

The safety instructions in Pfeiffer Vacuum operating instructions are the result of risk evaluations and hazard analyses and are oriented on international certification standards as specified by UL, CSA, ANSI Z-535, SEMI S1, ISO 3864 and DIN 4844. In this document, the following hazard levels and information are considered:

DANGER
Imminent danger Indicates an imminent hazardous situation that will result in death or serious injury.
WARNING
Possibly imminent danger Indicates an imminent hazardous situation that can result in death or serious injury.
CAUTION
Possibly imminent danger Indicates an imminent hazardous situation that can result in minor or moderate injury.
NOTICE
Command or note Command to perform an action or information about properties, the disregarding of which may result in damage to the product.

Pictographs



Prohibition of an action or activity in connection with a source of danger, the disregarding of which may result in serious accidents



Warning of a displayed source of danger in connection with operation of the unit or equipment



Command to perform an action or task associated with a source of danger, the disregarding of which may result in serious accidents



Important information about the product or this document

Instructions in the text

→ Work instruction: here you have to do something.

Abbreviations used

DCU: Display Control Unit
HPU: Handheld Programming Unit
TC: Electronic drive unit for turbopump
TPS: Mains pack

Symbols used

The following symbols are used consistently throughout the diagrams:

- Ⓜ High vacuum flange
- Ⓥ Fore-vacuum flange
- Ⓣ Electric connection
- Ⓧ Cooling water connection
- ⓕ Venting connection
- Ⓢ Sealing gas connection

2 Safety

2.1 Safety precautions



Duty to inform

Each person involved in the installation, operation or maintenance of the vacuum pump must read and observe the safety-related parts of these operating instructions.

→ The operator is obligated to make operating personnel aware of dangers originating from the vacuum pump, the pumped medium and the entire system.



Installation and operation of accessories

Pfeiffer Vacuum pumps can be equipped with a series of adapted accessories. The installation, operation and maintenance of connected devices are described in detail in the operating instructions of the individual components.

→ For information on order numbers of components, see "Accessories".

→ Use original accessory parts only.



NOTICE

Checking the safety system against excess rotation speed

To provide the functioning of the integrated safety system for avoiding excess rotation speed, the pump must run-up from the standstill at least once a year.

→ Switch off the pump and await the complete standstill (rotation speed = 0 Hz).

→ Run-up the pump according to this operating instructions.



WARNING

Danger of unsafe electrical installation

Safe operation after installation is the responsibility of the operator.

→ Do not independently modify or change the pump and electrical equipment.

→ Make sure that the system is integrated in an emergency off safety circuit.

→ Consult Pfeiffer Vacuum for special requirements.



WARNING

Danger due to lack of power disconnection device as defined in SEMI-S2

Pump and electronic drive unit are not equipped with a power disconnection device. Installation of a user-supplied power disconnection device in accordance with SEMI-S2.

→ Fit a circuit breaker with an interruption rating of min. 10,000 A.



WARNING

Danger of electric shock

In case of defect, the parts connected to the mains supply are under voltage.

→ Always keep the mains connection freely accessible so you can disconnect it at any time.

- Do not expose any body parts to the vacuum.
- Observe all safety and accident prevention regulations.
- Regularly check the proper observance of all safety measures.
- **Power supply:** The turbopump power supply must apply to the requirements of double insulation between mains input voltage and operating voltage according to the regulations of IEC 61010 and IEC 60950. Therefore Pfeiffer Vacuum recommends to use exclusively original-power packs and -accessories. Only in this case Pfeiffer Vacuum is able to guarantee the compliance of the European and North American guidelines.
- A safe connection to the protective earthing conductor (PE) is recommended (protection class III).

- Do not loosen any plug connection during operations.
- Wait for the rotor to reach standstill before performing work on the high vacuum flange.
- Keep leads and cables well away from hot surfaces (> 70 °C).
- Never fill or operate turbopump with cleaning agent.
- Do not operate the turbopump with open high vacuum flange.
- Do not carry out any unauthorized modifications or conversions to the pump.
- When returning the turbopump observe the shipping instructions.

2.2 Protective equipment

Determined situations concerning the handling of vacuum pumps require wearing of personal protective equipment. The owner, respectively the employer are obligated to provide adequate equipment to any operating persons.



DANGER	
<p>Danger to health by hazardous substances during maintenance or installation Depending on the process vacuum pumps, components or operating fluids can be contaminated by toxic, reactive or radioactive substances.</p> <p>→ Wear adequate protective equipment during maintenance and repairs or in case of reinstallation.</p>	



WARNING	
<p>Risk of injury through falling objects When transporting vacuum pumps by hand, there is a danger through loads slipping and falling down.</p> <p>→ Carry small and mid-size vacuum pumps two-handed. → Carry vacuum pumps > 20 kg by a suitable lifting device. → Wear safety shoes with steel toe cap according to directive EN 347.</p>	



CAUTION	
<p>Risk of injury through hot surfaces Vacuum pumps can become hot during operation.</p> <p>→ Allow the pump to cool before maintenance and repairs. → If necessary wear protective gloves according to directive EN 420.</p>	



CAUTION	
<p>Risk of injury through sharp edges Rotor and stator disks of turbopumps have very sharp edges.</p> <p>→ Before any working wait for the complete standstill of the pump. → Do not reach in the high vacuum flange. → If necessary wear protective gloves according directive EN 420.</p>	

2.3 Proper use



NOTICE

EC conformity

The manufacturer's declaration of conformity becomes invalid if the operator modifies the original product or installs additional components.

→ Following installation into a plant and before commissioning, the operator must check the entire system for compliance with the valid EU directives and reassess it accordingly.

- The vacuum pump may only be used to generate a vacuum.
- Only operate the turbopump with an approved backing pump.

2.4 Improper use

Improper use will cause all claims for liability and warranties to be forfeited. Improper use is defined as usage for purposes deviating from those mentioned above, especially:

- pumping of corrosive or explosive media
- pumping of condensing vapors
- pumping of liquids
- pumping of dusts without using of sealing gas
- operation with improper high gas throughput
- operation with improper high fore-vacuum pressures
- operation with improper high levels of insulated heat input
- operation in improper high magnetic fields
- operation with improper gas mode
- venting with improper high venting rates
- use of the vacuum pump to generate pressure
- operation of the devices in areas with ionizing radiation
- operation in potentially explosive areas
- use of the devices in systems in which impact-like stress and vibrations or periodically forces affect the devices
- use of accessories or spare parts, which are not named in this manual

warranty seal

PFEIFFER  **VACUUM**

Closure seal

The product is sealed at the factory. Damaging or removal of a closure seal leads to the loss of liability and warranty entitlements.

→ Do not open the product within its warranty period!

→ For process-related shorter maintenance intervals please contact the Pfeiffer Vacuum Service.

3 Transport and storage

3.1 Transport

- Reuse the transport container. Vacuum pumps should be transported or shipped in the original packing only.
- Only remove the protective covers from the high vacuum and the fore-vacuum side immediately before connection.
- Keep the original protective covers.
- Always transport the turbopump in an upright position.

3.2 Storage

- Close the flange openings by using the original protective covers.
- Close further connection ports by using the corresponding protective covers.
- Store the pump only indoors at temperatures between -25 °C and +55 °C.
- In rooms with moist or aggressive atmospheres, the pump must be airtight shrink-wrapped in a plastic bag together with a bag of desiccant.

4 Product description

4.1 Product identification

Pump types

The product designation consists of a family designation (1), the size (2), which is oriented on the pumping speed, and if applicable the additional properties (3) of the pump.

HiPace⁽¹⁾ 60⁽²⁾P⁽³⁾

1. Family designation	2. Model designation	3. Property designation
HiPace	60 = Model designation of the pump related to its pumping speed class	none = Standard version U = Upside-down installation orientation C = Corrosive gas version P = Process M = Active magnetic bearing T = Temperature management system

Pump features

C
1

This product has been tested to the requirements of CAN/CSA-C22.2 No. 61010-1, second edition, including Amendment 1, or a later version of the same standard incorporating the same level of testing requirements.

For information about other certifications, if applicable, please see the signet on the product or:

- www.tuvdotcom.com
- TUVdotCOM-ID 0000021320

Characteristics	HiPace 60 P
HV flange	DN 63 ISO-K
Flange material	Aluminium

To correctly identify the product when communicating with Pfeiffer Vacuum, always have the information from the rating plate available.

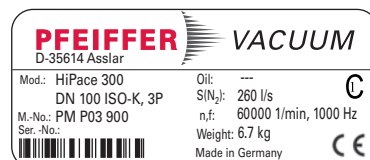

Fig. 1: Example for a rating plate

Scope of delivery

- HiPace 60 P with TC 110 and 24 V DC \pm 5 %
- Protective cover for the high vacuum flange and the fore-vacuum flange
- Operating instructions

4.2 Function

The turbopump HiPace 60 P forms a complete unit together with the electronic drive unit TC 110. For the voltage supply only Pfeiffer Vacuum power supplies may be used (e.g. TPS or DCU).

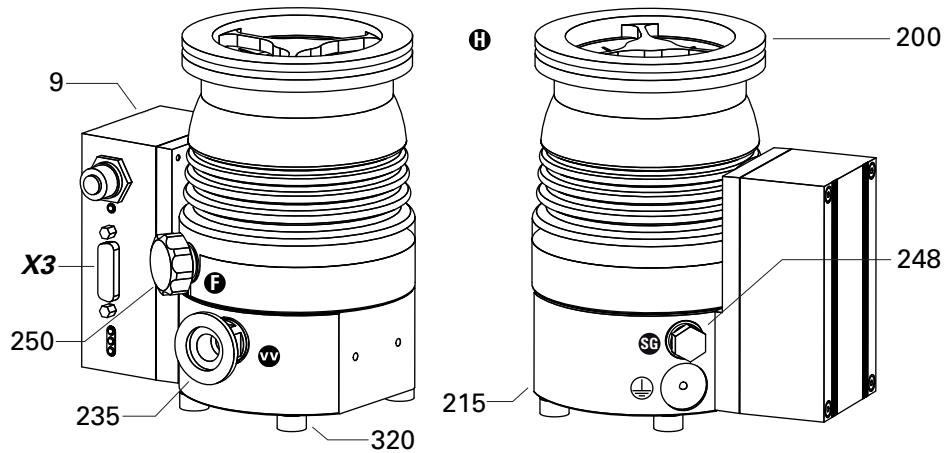

Fig. 2: View of HiPace 60 P with TC 110

8	Electronic drive unit TC 110	235	Fore-vacuum connection	320	Anti-vibration buffer
200	Pump housing	248	Sealing gas connection	X3	Multi-functional connection
215	Pump lower part	250	Venting connection		

Cooling

- Convection cooling
- Air cooling (optional)
- Water cooling (optional)

In the case of excess temperature the electronic drive unit reduces the drive power automatically. Depending on the application and the HiPace different cooling variants are selectable.

Rotor bearing

Hybrid bearing turbopump

- High vacuum side: maintenance-free permanent magnetic bearing
- Fore-vacuum side: ceramic ball bearing

Drive

Electronic drive unit TC 110

4.3 Range of application

The pump HiPace 60 P must be installed and operated under the following ambient conditions:

Installation location	weather protected (indoors)
Protection category	IP 54
Protection class	III
Ambient temperature	+5 °C to +30 °C with convection cooling without gas throughput +5 °C to +35 °C with air cooling +5 °C to +40 °C with water cooling
Relative humidity	max. 80 %, at $T \leq 31$ °C, up to max. 50% at $T \leq 40$ °C
Atmospheric pressure	750 hPa - 1060 hPa
Installation altitude	2000 m max.
Degree of pollution	2
Permissible surr. magnetic field	≤ 4 mT
Overvoltage category	II
Connection voltage TC	24 V DC $\pm 5\%$



Remarks to ambient conditions

The specified permissible ambient temperatures apply to operation of the turbopump at maximum permissible fore-vacuum pressure or at maximum gas throughput depending on the cooling method. The turbopump is intrinsically safe by a redundant temperature monitoring.

- By reducing the fore-vacuum pressure or gas throughput, the turbopump can be operated at higher ambient temperatures.
- If the maximum permissible operating temperature of the turbopump is exceeded, the electronic drive unit reduces drive power first and switches off then, if necessary.

5 Installation



WARNING

Risk of the turbopump being torn-off

In case of sudden blocking of the rotor, torques of up to 620 Nm can occur, which can lead with incorrect attachment to tearing the turbopump off. The energy released thereby can hurl the entire pump or fragments from their inside around the area. This can cause severest injuries (possibly resulting in death) and large property damage.

- Precisely follow installation instructions.
- Only use Pfeiffer Vacuum original components (accessories) for installation.



Installation and operation of accessories

Pfeiffer Vacuum pumps can be equipped with a series of adapted accessories. The installation, operation and maintenance of connected devices are described in detail in the operating instructions of the individual components.

- For information on order numbers of components, see "Accessories".
- Use original accessory parts only.

5.1 Set-up

When installing the pump, observe the following conditions:

- the ambient conditions specified for the range of application
- When using a casing heating and a water cooling unit the temperature of the connected flange of the vacuum chamber must not exceed 120 °C.
- The pump may be fastened to the floor only after consultation with Pfeiffer Vacuum.
- It is not allowed to operate the device in systems where impact-like stresses and vibrations or periodically forces occur.

5.2 Preparatory work

- Ensure sufficient cooling for the turbopump.
- Where magnetic fields > 4 mT are involved, a suitable shielding must be used. Check installation location and consult Pfeiffer Vacuum if needed!
- The maximum permissible rotor temperature for the turbopump is 90 °C. If high temperatures arise for process reasons, the radiated heat input must not exceed 1.2 W. Install suitable screening sheets, if necessary (design information on request).

5.3 Assembly

- Ensure the greatest possible cleanliness when installing any high vacuum parts. Unclean components prolong the pump-down time.
- All flange components must be grease-free, dust-free and dry at installation.
- The operating fluid reservoir is already installed and filled for the turbopump HiPace 60 P.

Earthquake safety

An earthquake can result in contact with the safety bearings. All forces occurring hereby are safely absorbed by the properly installed flange connections.

- The vacuum chamber must be secured by the customer against shifting and tipping.

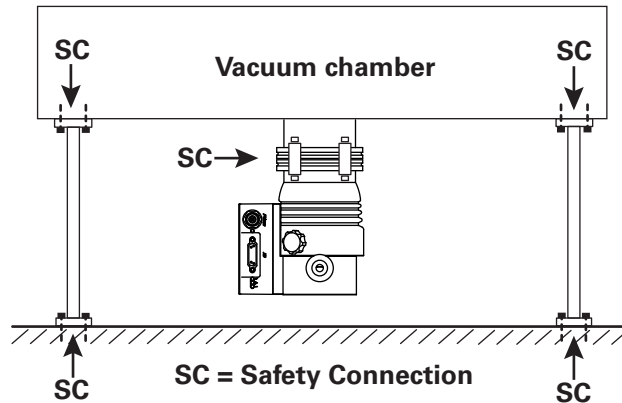

Fig. 3: Example: How to secure against shifting and tipping by external tremors

Use of a splinter shield or protection screen

The installation of a Pfeiffer Vacuum centering ring with splinter shield or protection screen in the high vacuum flange protects the turbopump against foreign bodies coming from the chamber. The pumping speed is reduced.

	Reduced pumping speed in %			
	H ₂	He	N ₂	Ar
Splinter shield DN 63	3	6	15	16
Protection screen DN 63	1	1	4	4

Vibration damper



WARNING

Danger from the turbopump and vibration damper being torn-off

In case of sudden blocking of the rotor, an applied vibration damper cannot compensate any of the occurring forces. There is a danger of the turbopump being torn-off and thereby resulting severest injuries and property damages. Applicable safeguards must be taken to compensate possible occurring torques.

- Definitely consult with Pfeiffer Vacuum.
- Do not exceed the max. permissible temperature at the vibration damper (100 °C).

Mounting orientation

When using dry backing pumps, Pfeiffer Vacuum HiPace pumps are designed for installation in any orientation.

- Support pipes in front of the vacuum pump or remove them. No force from the pipe system may be exerted on the fixed pump.
- To avoid contamination via the fore-vacuum line when using oil-sealed backing pumps the fore-vacuum flange should always point vertically downward ($\pm 25^\circ$).

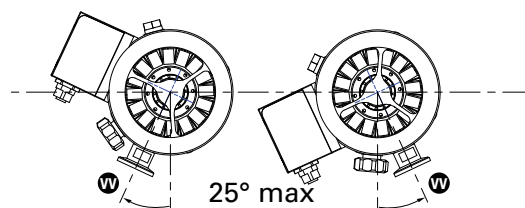

Fig. 4: Recommended orientation of the fore-vacuum flange

The maximum axial loading capacity of the high vacuum flange is 200 N (equals 20 kg). A one-sided load on the high vacuum flange is not permitted.

Installing the high vacuum flange

In the case the rotor suddenly blocks, the torques arising from the system and the high vacuum flange must be absorbed. Only the components listed in the following can be used to fasten the turbopumps to the high vacuum flange. The components for installing the turbopumps are special designs of Pfeiffer Vacuum. Observe the minimum strength of 170 N/mm^2 for the flange material.



NOTICE

Observe shape tolerances for the counter flange!

Unevennesses of the customer supplied counter flange can lead to warping of the pump casing despite proper fastening. Leakiness and negative running characteristics can be the result.

→ Do not exceed an evenness of max. 0.05 mm for the whole surface.



Mounting of ISO flanges

If the rotor suddenly blocks the connection of high vacuum flanges of types ISO-KF or ISO-K can lead to twisting despite proper installation.

- The tightness of the high vacuum flange is not at risk thereby.

Installation of ISO-K flange with ISO-K flange

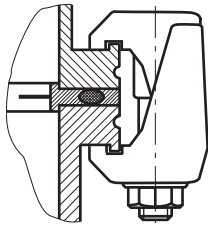

For the installation of the flange connections the following components are available:

- the valid mounting kit of the Pfeiffer Vacuum accessories programme
 - protection screen or splinter shield are optionally
- Mind that the sealing surfaces are not damaged.
- Connect the flanges according to the drawing and with the component parts of the mounting kit.
- Use the required number of 4 claw clamps.
- Tighten the claw clamps crosswise in three steps.
- Tightening torque: 5, 15, 25 \pm 2 Nm

Installation of ISO-K flange with ISO-F flange

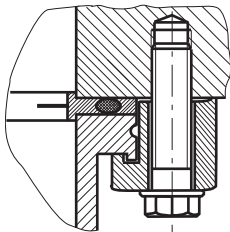

For the installation of the flange connections the following components are available:

- the valid mounting kit of the Pfeiffer Vacuum accessories programme
 - protection screen or splinter shield are optionally
- Mind that the sealing surfaces are not damaged.
- Connect the flanges according to the drawing and with the component parts of the mounting kit.
- Use the required number of 4 claw grips.
- Tighten the claw grips crosswise in three steps.
- Tightening torque: 3, 10, 16 \pm 1 Nm.

5.4 Connections to the turbopump

Electronic drive unit

Turbopumps with integrated electronic drive unit are designed for various applications. Therefore different connection panels are available.

- TC 110 in standard version
- TC 110 PB for Profibus linking
- TC 110 E74 in dependence on specification SEMI E74
- TC 110 DN for DeviceNet linking
- TC 110 RS with interface RS-485

Detailed description for function, configuration and operation with the respective connection panel are given in the specific operating instructions for the electronic drive unit.

Connecting the power supply

For voltage supply of the electronic drive unit TC 110, only use original power supplies (e.g. TPS 110 or DCU 110). Use of other power supplies only after consultation with Pfeiffer Vacuum. Connecting cables are available from the Pfeiffer Vacuum accessories.

Connecting cable	Function
TC 110 - TPS/DCU 110/180 with bridges, RS-485	<ul style="list-style-type: none"> • Voltage supply via power supply pack • Automatic start by bridges on pins 2, 5, 7 • Connection to a display and control unit via RS-485
TC 110 - TPS/DCU 110/180 with accessory ports, RS-485	<ul style="list-style-type: none"> • Voltage supply via power supply pack • Accessory connection via M8 plugs • Connection to a display and control unit via RS-485
TC 110 - TPS 110/180 with bridges	<ul style="list-style-type: none"> • Voltage supply via power supply pack • Automatic start by bridges on pins 2, 5, 7
TC 110 - TPS 110/180 with bridges, with accessory ports	<ul style="list-style-type: none"> • Voltage supply via power supply pack • Automatic start by bridges on pins 2, 5, 7 • Accessory connection via M8 plugs



WARNING

Danger of electric shock

In case of defect, the parts connected to the mains supply are under voltage.

→ Always keep the mains connection freely accessible so you can disconnect it at any time.

→ Make sure that the voltage of the turbopump is valid.

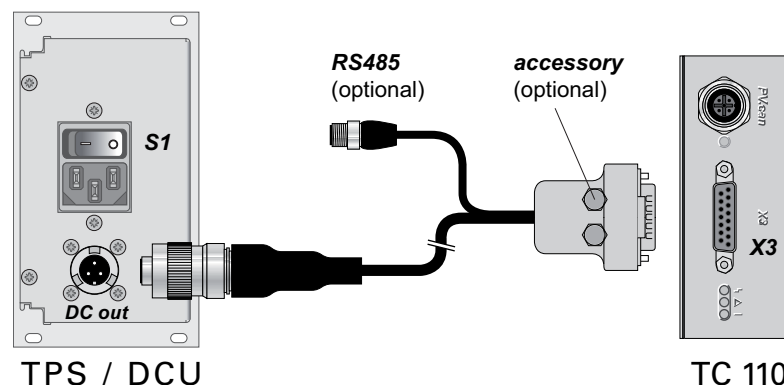

Fig. 5: Connecting the TC 110 to a power supply using a Pfeiffer Vacuum connecting cable

- Switch off switch S1 on the power pack (position "0").
- Place and fix the connecting cable with the 15-pole mating plug into the connection "X3" on the electronic drive unit.
- Insert the connection cable with the plug in the connection "DC out" on the power supply and close the bayonet lock.

When using a Pfeiffer Vacuum display and control unit:

→ Connect the display and control unit to the plug "RS485" of the adapter or the connecting cable.

Accessory connection

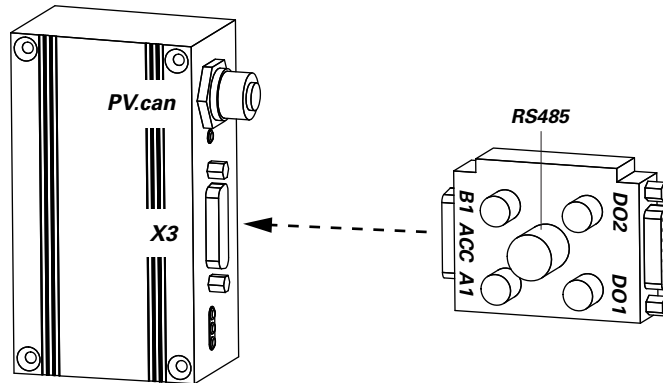

Fig. 6: Example: Connections on the electronic drive unit TC 110 with adapter TCS 12



Accessory connection on the TC 110

The connection of Pfeiffer Vacuum accessory units to the electronic drive unit TC 110 is only possible by using respective connecting cables or adapters.

- Configure the preferred accessory output via RS-485 using a Pfeiffer Vacuum display and control unit or a PC.
- Consider the operating instructions "Electronic Drive Unit TC 110".



Accessory connection to an electronic drive unit in special design

Differing to the standard model, drive units in special design (e.g. Profibus panel) can be equipped with accessory connections.

- Refer to the operating instructions of the respective electronic drive unit.
- Connect the control lead of the accessory directly to the electronic drive unit.
- Configure the preferred accessory output via RS-485 using a Pfeiffer Vacuum display and control unit or a PC.

Connecting the fore-vacuum side

Recommendation: As backing pump, use a dry-compressing vacuum pump or a rotary vane pump from the Pfeiffer Vacuum programme. The backing pump must generate a vacuum pressure of ≤ 1 hPa.



WARNING

Damage to health due to poisonous gases

Process gases can damage health and contaminate the environment.

- Safely lead away the gas emission from the backing pump!
- Observe all safety recommendations of the gas producer.

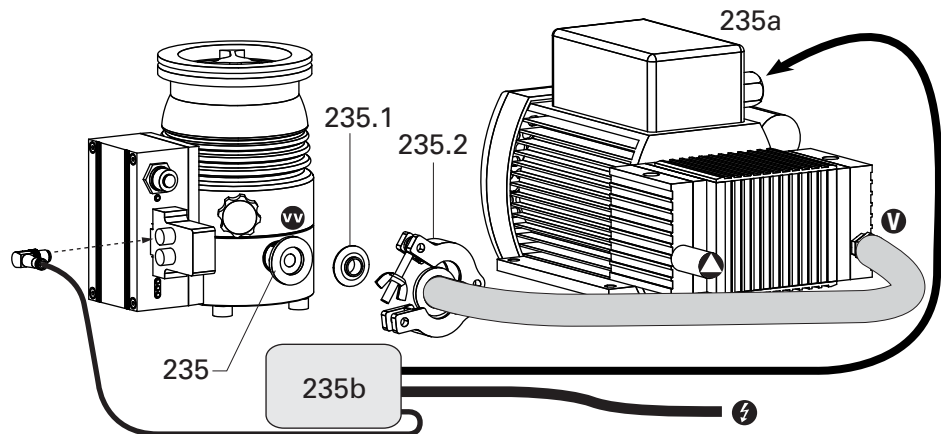

Fig. 7: Connecting the backing pump

235 Fore-vacuum connection
235a Backing pump

235b Backing pump relay box
235.1 Centering ring

235.2 Clamping ring



NOTICE

Design of the fore-vacuum connection regarding sudden twisting of the pump

If the rotor suddenly blocks the connection of high vacuum flanges of types ISO-KF or ISO-K can lead to twisting despite proper installation.

- Keep masses small, which can be installed directly to the pump.
- Connect flexible line elements directly to the turbopump, if necessary.
- With rigid pipe connections: Install bellows for attenuation of vibrations in the connection line.
- Connect the fore-vacuum line with small-flange components or threaded hose couplings. Do not narrow the free cross section of the fore-vacuum flange!
- The backing pump is connected electrically via a relay box.
- Plug in and fix the accessory's control lead to a free connection port on the connecting cable or adapter of the electronic drive unit.
- Establish the mains supply for the relay box according to the accessory operating instructions.
 - Make sure the supply voltage for the backing pump is valid.
- Make the settings and control via the interfaces of the electronic drive unit.

Air cooling

Turbopumps with the electronic drive unit TC 110 (24 V DC) may be operated with air cooling up to an ambient temperature of +35 °C.

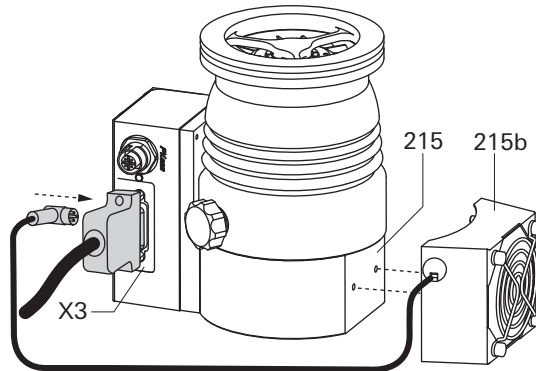

Fig. 8: Connecting the air cooling

215 Pump lower part 215b Air cooling unit X3 Multi-functional connection

- ➔ Fix the Pfeiffer Vacuum air cooling unit to the holes of the turbopump using two screws.
- ➔ Plug in and fix the accessory's control lead to a free connection port on the connecting cable or adapter of the electronic drive unit.
- ➔ Make the settings and control via the interfaces of the electronic drive unit.

Venting valve

The Pfeiffer Vacuum venting valve is used for automatic venting in case of shut-down or power failure.

The permissible connection pressure is max. 1500 hPa absolute.

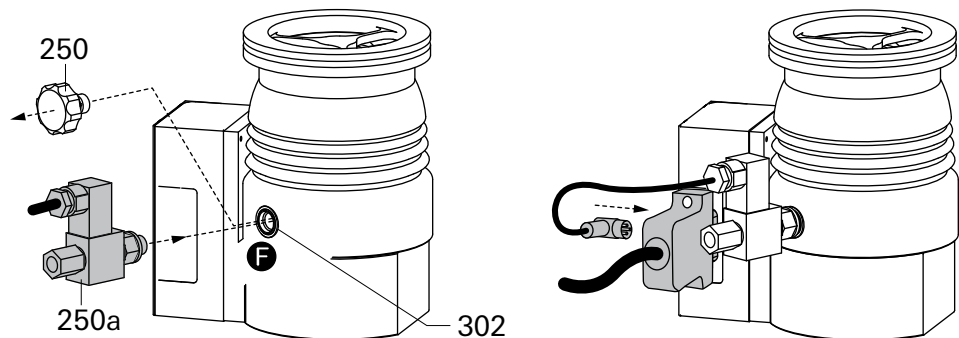

Fig. 9: Connecting the venting valve

302 Seal ring 250 Venting screw 250a Venting valve

- ➔ Unscrew the venting screw with seal ring from the venting connection.
- ➔ Screw in the venting valve with seal ring.
- ➔ Plug in and fix the accessory's control lead to a free connection port on the connecting cable or adapter of the electronic drive unit.
- ➔ Make the settings and control via the interfaces of the electronic drive unit.
- ➔ If necessary install a venting gas supply (e.g. inert gas) to the intake (G 1/8") of the solenoid valve.

Sealing gas connection

The turbopump must be operated with sealing gas to protect it, such as in the case of unclean processes or high gas throughput. The supply is made via a sealing gas valve or alternatively via a sealing gas throttle without control. The activation of the control valve for the sealing gas connection is not pre-installed in the electronic drive unit and has to be configured via their interfaces.

The permissible connection pressure is max. 1500 hPa absolute.

- When operating the pump with more than 50 % of the maximum gas throughput, sealing gas must be used to ensure rotor cooling.

- The sealing gas flow rate amounts 7.5 - 9.5 sccm for the HiPace 60 P.

Sealing gas supply without control valve

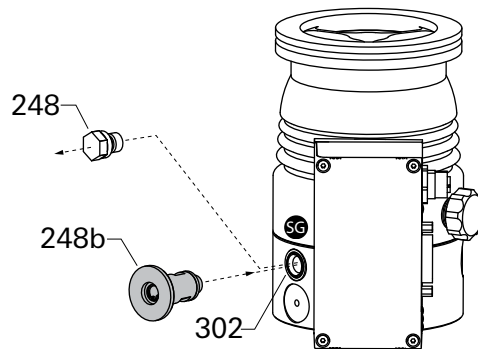

Fig. 10: Connecting the sealing gas throttle

248 Locking screw 248b Sealing gas throttle 302 Seal ring

- ➔ Unscrew the locking screw with seal ring out of the sealing gas connection.
- ➔ Screw the sealing gas throttle with sealing ring into the sealing gas connection.

Sealing gas supply with control valve

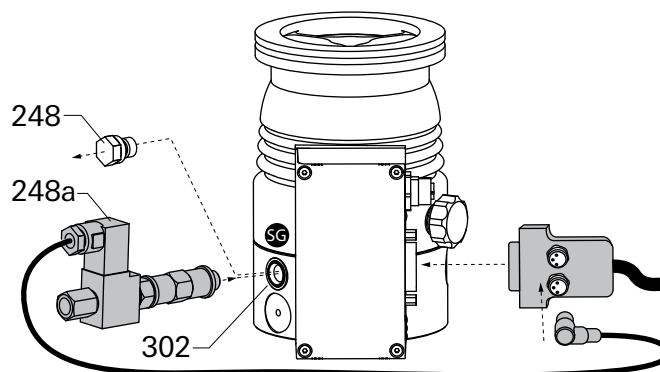

Fig. 11: Connecting the sealing gas valve

302 Seal ring 248 Locking screw 248a Sealing gas valve

- ➔ Unscrew the locking screw with seal ring out of the sealing gas connection.
- ➔ Screw the sealing gas valve with seal ring into the sealing gas connection.
- ➔ Plug in and fix the accessory's control lead to a free connection port on the connecting cable or adapter of the electronic drive unit.
- ➔ Make the settings and control via the interfaces of the electronic drive unit.
- ➔ Install the sealing gas supply (e.g. inert gas) via a connection adapter or on the inlet side (G 1/8") of the control valve.

Water cooling

As an option turbopumps HiPace 60 P with TC 110 can be equipped with water cooling.

- In case of increased backing pressure (> 0.1 hPa) and/or operation with high gas throughputs, either air or water cooling may be used.
- Generally use water cooling if the ambient temperature is > +35 °C.

Cooling water requirements

Cooling water connection	Socket connection
Hose lines	External diameter 8 mm Internal diameter 6 mm
Cooling water quality	filtrated, mechanically clean, optically clear, no turbidity, no sediments, chemically neutral
Oxygen content max.	4 mg/kg
Chloride content max.	100 mg/kg
Water hardness max.	10 °dH 12.53 °e 17.8 °fH 178 ppm CaCO ₃
Consumption of potassium permanganate max.	10 mg/kg
Carbon dioxide content max.	undetectable
Ammonia content max.	undetectable
pH-value	7 - 9
Fore-line overpressure max.	6000 hPa
Cooling water temperature	refer to "Technical Data"
Cooling water consumption at max. gas throughput	refer to "Technical Data"

Connecting to a cooling water system

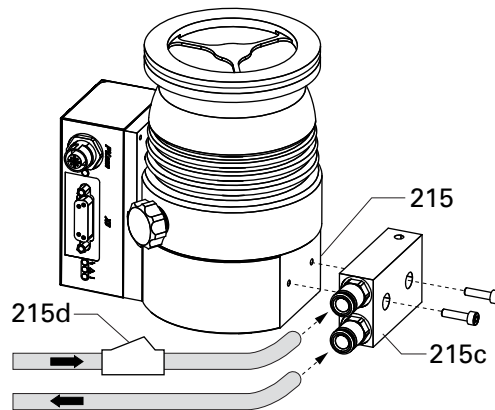

Fig. 12: Connecting the cooling water

215 Pump lower part 215c Water cooling unit 215d Dirt trap

- ➔ Fix the water cooling unit sideways on the pump lower part.
- ➔ Insert hoses for the water cooling fore- and return-line as far as they will go in one cooling water connection each.
- ➔ **Recommendation:** install dirt trap in the fore-line.

6 Operation

6.1 Commissioning

The following important settings are programmed in the electronic drive unit ex factory.

- Parameter **[P:027]** Gas mode: 0 = heavy gases
 - Parameter **[P:700]** Set value max. run-up time monitoring: 8 min
 - Parameter **[P:701]** Rotation speed switchpoint: 80% of the nominal rotation speed
 - Parameter **[P:707]** Set value rotation speed setting mode: 65% of the nominal rotation speed
 - Parameter **[P:708]** Set value power consumption: 70 %
 - Parameter **[P:720]** Venting rotation speed at delayed venting: 50 % of the nominal rotation speed
 - Parameter **[P:721]** Venting time: 3600 s
- When water cooling is used: Open cooling water supply and check the flow.
 → When sealing gas is used: Open the sealing gas supply and check the flow.
 → Establish the mains for the power supply.



NOTICE

Risk of destroying the pump by inputting too much energy

Simultaneous loading by means of high drive power (gas flow rate, fore-vacuum pressure), high heat radiation, or strong magnetic fields results in uncontrolled heating of the rotor and may destroy the pump.

- Reduced limit values apply when combining these loads.
- If necessary consult with Pfeiffer Vacuum.



NOTICE

Danger of the pump being destroyed

Pumping of gases with a higher molecular mass in the wrong gas mode can lead to destruction of the pump.

- Ensure the gas mode is correctly set.
- Contact Pfeiffer Vacuum before using gases with a greater molecular mass (> 80).

6.2 Operation modes

The following operation modes are available:

- Operation without operating unit
- Operation via "X3" connection
- Operation via RS-485 and Pfeiffer Vacuum display and control units or PC
- Operation via field bus

6.3 Function description



WARNING

Danger due to open high vacuum flange

The rotor of the turbopump turns at high speed. If the high vacuum flange is open, there is a danger of cut injuries and that the pump can be destroyed by objects falling into it.

- Never operate the pump with an open high vacuum flange.

Operation without operating unit



CAUTION

Automatic start
 After bridging the contacts Pin 2, 5, 7 on the connection "X3" or using a connecting cable "with bridges" **and** setting up the supply voltage, the turbopump will run up immediately.
 → Switch on the mains supply on the turbopump immediately before operation.

- For operation without the control unit, the respective connecting cable "with bridges" must be in the "X3" connection on the TC 110.
- Switch on the supply voltage with switch S1 on the power supply.

After operating voltage is applied, the TC 110 performs a self-test to check the supply voltage. Once the self-test has been successfully completed on the TC 110, the turbopump and the backing pump - if connected - begin to operate.

Operation via "X3" connection

Remote control options are provided via the 15-pole D-sub connector with the designation "X3" on the electronic drive unit.

- Consider the following manuals for the operation via remote control:
 - Operating instructions "Electronic drive unit TC 110"

Operation with DCU or HPU

→ Consider the following manuals for the operation via Pfeiffer Vacuum display and control units:

- Operating instructions "DCU"
- Operating instructions "HPU"
- Operating instructions "Electronic drive unit TC 110"

- Connect the display and control unit to the plug "RS485" of the adapter or the connecting cable.
- Switch on the supply voltage with switch S1 on the power supply or on the DCU 110.
- Settings are possible via the RS-485 by using DCU, HPU or PC.

Operation via field bus

Integrating and operating Pfeiffer Vacuum turbopumps in the customer's field bus system is possible for electronic drive units with a corresponding field bus panel.

- Consider the following manuals for the operation via field bus:
 - Operating instructions for the electronic drive unit with the respective connection panel

6.4 Monitoring of the operation conditions

Operating mode display via LED

LEDs in the front panel of the electronic drive unit show basic operating conditions of the turbopump. A differentiated malfunction and warning display is possible only for operation with DCU or HPU.

LED	Symbol	Steady OFF	Flashing (1/12 s active)	Blinking (1/2 s active)	Steady ON
Green		insufficient power supply	Pumping station "OFF" Rotation speed ≤ 1Hz	Pumping station "OFF" Rotation speed > 1 Hz	Pumping station "ON"
Yellow	△	no warning			Warning
Red	⚡	no malfunction			Malfunction

Temperature monitoring The drive power is reduced in case of impermissible motor temperature or impermissibly high housing temperature. This can cause falling below the rotation speed switchpoint and so result in turning off the turbopump.

6.5 Switching off and venting

Switching off After the turbopump is switched off, it must be vented to avoid contamination due to particles streaming back from the fore-vacuum area.

- Close the fore-vacuum line: Switch off the backing pump or close a fore-vacuum valve.
- Switch off the turbopump on the control unit or via remote control.
- Venting (possibilities, see below)
- For water cooling: Shut off the water supply.

Venting

Manually venting

- Open the venting screw (included) in the venting connection of the turbopump about one turn.

Venting with Pfeiffer Vacuum Venting Valve

- Enable venting via the functions of the electronic drive unit.
- Settings are possible via the RS-485 by using DCU, HPU or PC.

Venting rotation speed	Switch off the pumping station	Mains power failure ¹⁾
50 % of the nominal rotation speed	Venting valve opens for 3600 s (1 h, works setting)	Venting valve opens for 3600 s (1 h, works setting)

¹⁾When mains power is restored the venting procedure is aborted.

Basic information for the rapid venting



NOTICE

Danger of excessive inlet pressure

The gas flow of the venting gas supply increases according to the inlet pressure. Unacceptably high rates of pressure rise while venting can damage the pump.

- When using venting gas at excess pressure, the permissible rate of pressure rise must be observed.

Venting of the vacuum chamber in two steps. Ask for details on individual solutions from Pfeiffer Vacuum.

- Vent for 20 seconds at a rate of pressure rise of max. 15 hPa/s.
 - The valve cross section for the venting rate of 15 hPa/s must be adapted to the size of the vacuum chamber.
 - For small vacuum chambers, use the Pfeiffer Vacuum venting valve.
- Then vent with an additional venting valve of any desired size.

7 Maintenance / replacement



WARNING

Contamination of parts and operating fluid by pumped media is possible.

Poisoning hazard through contact with materials that damage health.

- In the case of contamination, carry out appropriate safety precautions in order to prevent danger to health through dangerous substances.
- Decontaminate affected parts before carrying out maintenance work.



NOTICE

Disclaimer of liability

Pfeiffer Vacuum accepts no liability for personal injury or material damage, losses or operating malfunctions due to improperly performed maintenance. The liability and warranty entitlement expires.

7.1 Maintenance intervals and responsibilities

- Clean the turbopump externally with a lint-free cloth and little industrial alcohol.
- Replace the operating fluid reservoir and electronic drive unit yourself.
- Change the operating fluid reservoir at least every 4 years.
- Change the turbopump bearing at least every 4 years.
 - Contact Pfeiffer Vacuum Service.
- Clarify shorter maintenance intervals for extreme loads or impure processes with Pfeiffer Vacuum Service.
- For all other cleaning, maintenance or repair work, please contact your Pfeiffer Vacuum service location.

7.2 Replacing the operating fluid reservoir



WARNING

Poisoning hazard through contact with materials that damage health.

The operating fluid reservoir and parts of the pump may contain toxic substances from the pumped media.



- Dispose of operating fluid reservoir in accordance with the applicable regulations. Safety data sheet on request or under www.pfeiffer-vacuum.com
- Prevent health hazards or environmental damage due to contamination by means of appropriate safety precautions.
- Decontaminate affected parts before carrying out maintenance work.



Operating fluid filling

The operating fluid reservoir is sufficiently filled with operating fluid.

- Do not add additional operating fluid.
- Turn off the vacuum pump, vent to atmospheric pressure and allow to cool, if necessary.
- Remove the vacuum pump from the system, if necessary.
- Close the flange openings by using the original protective covers.
- Turn the turbopump over onto the closed high vacuum flange.

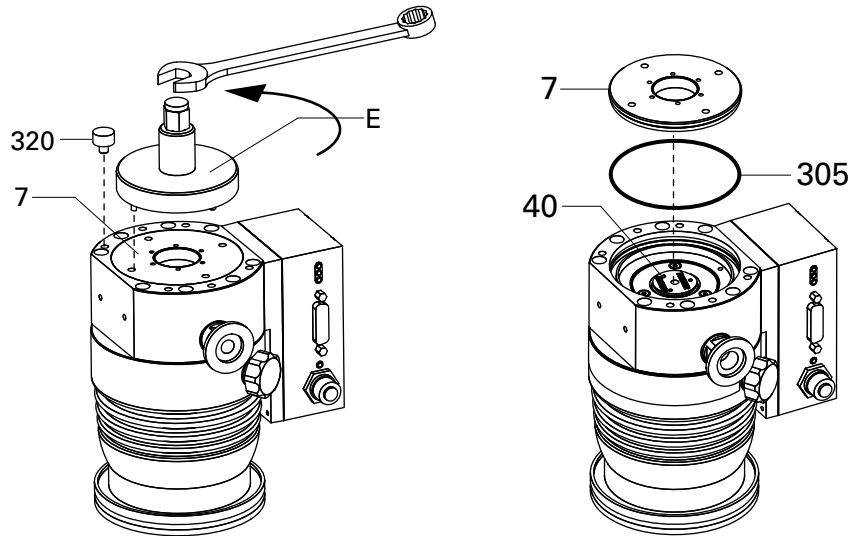
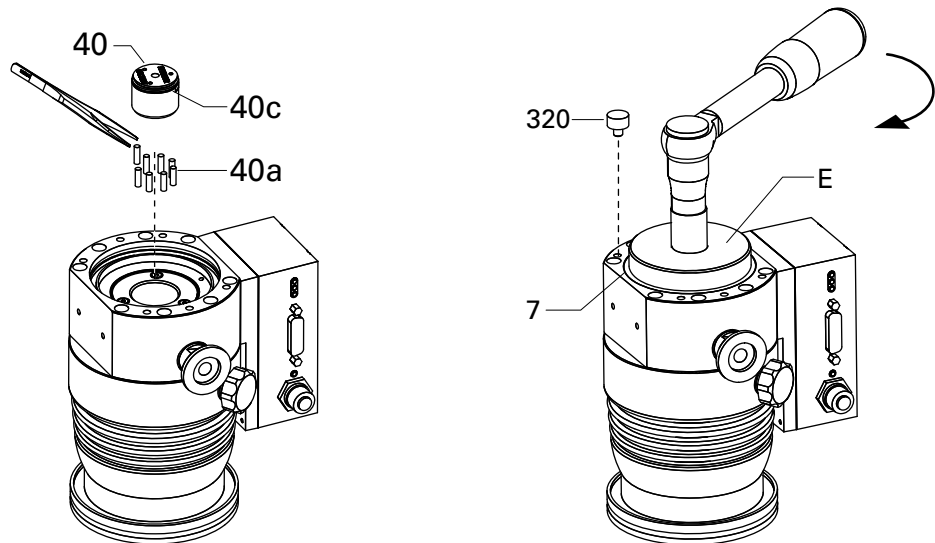

Fig. 13: Assembly / Disassembly of the operating fluid reservoir

7	End cover	40c	O-ring	320	Rubber foot
40	Operating fluid reservoir	305	O-ring	E	Key for end cover (PV M40 813)
40a	Poroplast rod				

- Unscrew the rubber feet 320 from the pump bottom part.
- Screw out the end cover 7 on the bottom of the turbopump with special tool E. Pay attention to O-ring 305.



- Lift out the operating fluid reservoir using two screwdrivers.
- Using tweezers, pull out the Poroplast rods (9 pieces).
- Remove impurities from the turbopump and the end cover with a clean, lint-free cloth.
Do not use any cleaning fluids!
- Using tweezers, insert the new Poroplast rods (9 pieces).
- Push the new operating fluid reservoir up to the O-ring 40c into the pump.
 - **Do not** perform any pressure upon the operating fluid reservoir!
- Screw in the end cover with the new O-ring 305. The operating fluid reservoir is brought into the correct axial position by the end cover.
- Observe the end cover's tightening torque **13 Nm ± 10 %**.
- Screw rubber feet into the pump bottom part.

7.3 Replacing the electronic drive unit

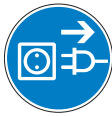

NOTICE

Damages to the pump and drive

Even after the mains power is switched off, the subsequently running pump delivers electric power to the electronic drive unit. There is a danger of electric body contact by premature separating the pump from the electronic drive unit.

→ Never separate the electronic drive unit from the pump when the mains power is connected or the rotor is running.



Operating parameters of the electronic drive unit

The factory operating parameters are always preset with replacement shipments.

→ The use of a HPU enables the storing and the reuse of an existing parameter record.

→ Reset any individually changed application parameters.

→ Refer to the manual "Electronic drive unit".

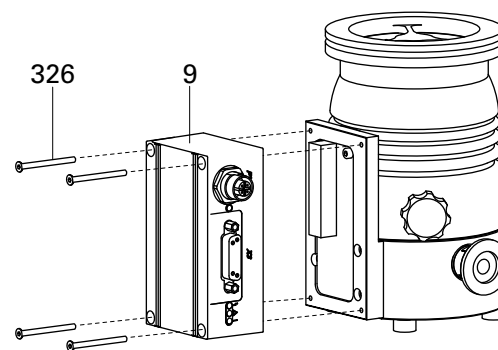

Fig. 14: Assembly / disassembly of the TC 110

9 Electronic drive unit 326 Allen head screw

- Do not exercise any mechanical load on the electronic drive unit.
- Turn off the vacuum pump, vent to atmospheric pressure and allow to cool, if necessary.
- Only separate the pump and the electronic drive unit from each other after disconnecting the supply voltage and the complete standstill of the pump.
- Remove the vacuum pump from the system, if necessary.
- Unscrew Allen head screws (4x) from the electronic drive unit.
- Pull the electronic drive unit off the pump.
- Screw on and connect new electronic drive unit to the turbopump.
 - Tightening torque: **0.6 - 0.8 Nm**.

Rotation speed set value

The typical nominal rotation speed of a turbopump is factory-set in the electronic drive unit. If the electronic drive unit is replaced or a different pump type is used, the reference set value of the nominal rotation speed must be confirmed. This procedure is part of a redundant safety system for avoiding excess rotation speeds.

HiPace	Nominal rotation speed confirmation [P:777]
10 / 60 / 80	1500 Hz
300	1000 Hz

- Adjust the parameter **[P:777]** according to the pump type.
- **Alternatively:** If no display and control unit is available, please use the "SpeedConfigurator" of the spare parts delivery.

8 Decommissioning

8.1 Shutting down for longer periods



WARNING

Contamination of parts and operating fluid by pumped media is possible.

Poisoning hazard through contact with materials that damage health.

- In the case of contamination, carry out appropriate safety precautions in order to prevent danger to health through dangerous substances.
- Decontaminate affected parts before carrying out maintenance work.

If the turbopump should be shut down for longer than a year:

- Remove the vacuum pump from the system, if necessary.
- Change the operating fluid reservoir.
- Close the high vacuum flange of the turbopump.
- Evacuate turbopump via the fore-vacuum flange.
- Vent turbopump via the venting connection with oil-free, dry air or inert gas.
- Close the flange openings by using the original protective covers.
- Close further connection ports by using the corresponding protective covers.
- Place pump upright on rubber feet.
- Store the pump only indoors at temperatures between -25 °C and +55 °C.
- In rooms with moist or aggressive atmospheres, the pump must be airtight shrink-wrapped in a plastic bag together with a bag of desiccant.

8.2 Re-starting



NOTICE

Restarting

The serviceability of the operating fluid of the turbopump without operation is a maximum of 4 years. Before restarting after a shut-down of **4 years or longer**, carry out the following work:

- Replace the operating fluid reservoir
- Replace bearings
- Follow the maintenance instructions and inform Pfeiffer Vacuum
- Check turbopump for contamination and moisture.
- Clean the turbopump externally with a lint-free cloth and little industrial alcohol.
- If necessary, have Pfeiffer Vacuum Service clean the turbopump completely.
- If necessary, have the bearings replaced. Take into account the total running time.
- Change the operating fluid reservoir.
- Installation and commissioning in accordance with the operating instructions.

8.3 Disposal

Products or parts thereof (mechanical and electrical components, operating fluids, etc.) may cause environmental burden.

- Safely dispose of the materials according to the locally applicable regulations.

9 Malfunctions

Please note the following instructions should the pump malfunction:

9.1 Rectifying malfunctions

Problem	Possible causes	Remedy
Pump will not start; none of the built-in LEDs on the TC 110 lights up	• Electrical supply interrupted	⇒ Check plug contacts on the power supply ⇒ Check supply lines on the power supply ⇒ Check the output voltage (24 V DC) on the connection "DC out" of the power supply ⇒ Check the plug contacts on the TC
	• Operating voltage incorrect	⇒ Apply correct operating voltage ⇒ Observe the rating plate
	• No operating voltage applied	⇒ Apply operating voltage
	• TC 110 defective	⇒ Exchange the TC 110 ⇒ Contact the Pfeiffer Vacuum Service
Pump will not start; green LED on the TC 110 is flashing	• At operation without control panel: Pins 2-7 and 5-7 are not connected on the "X3" connection	⇒ Connect the pins 2-7 and 5-7 on the "X3" connection
	• At operation via RS-485: Bridge at Pin 2-7 prevents control commands	⇒ Remove the bridge at the "X3" connection.
	• At operation via RS-485: Parameters of the electronic drive unit not set	⇒ Set parameters [P: 010] and [P: 023] "ON" via interface RS-485. ⇒ Please refer to operating instructions of the electronic drive unit.
	• Voltage drop in the cable too high	⇒ Use a suitable cable
Pump does not attain the final rotational speed within the specified run-up time	• Fore-vacuum pressure too high	⇒ Ensure function and suitability of the backing pump
	• Leak	⇒ Perform leak detection ⇒ Check sealings and flange fastenings ⇒ Eliminate leaks
	• Gas throughput too high	⇒ Reduce process gas supply
	• Rotor is rough-running, bearing defective	⇒ Check the bearing for noises ⇒ Contact the Pfeiffer Vacuum Service
	• Setpoint for run-up time to low	⇒ Extend the run-up time via DCU, HPU or PC
	• Thermal overload: – Lack of air ventilation – Water flow too low – Fore-vacuum pressure too high – Ambient temperature too high	⇒ Reduce thermal loads – Ensure adequate cooling – Ensure the cooling water flow – Lower the fore-vacuum pressure – Adjust ambient conditions
Pump does not attain the ultimate pressure	• Pump is dirty	⇒ Bake out the pump ⇒ Cleaning in case of heavy contamination – Contact the Pfeiffer Vacuum Service
	• Vacuum chamber, pipes or pump are leaky	⇒ Leak detection starting from the vacuum chamber ⇒ Eliminate leaks
Unusual noises during operation	• Bearing damage	⇒ Contact the Pfeiffer Vacuum Service
	• Rotor damage	⇒ Contact the Pfeiffer Vacuum Service
	• Splinter shield or protective screen are loose	⇒ Correct the seat of the splinter shield or the protective screen ⇒ Observe the installation notes
Red LED on the TC 110 is on	• Collective fault	⇒ Reset by switching the mains OFF/ON ⇒ Reset via pin 6 on the "X3" connection ⇒ Differentiated malfunction display is possible via DCU or HPU ¹⁾ ⇒ Contact the Pfeiffer Vacuum Service

¹⁾ If no display and control unit is available, please contact the Pfeiffer Vacuum Service.

10 Service

Pfeiffer Vacuum offers first-class service!

- Operating fluid and bearing change on the spot by Pfeiffer Vacuum FieldService
- Maintenance / repair in the nearby ServiceCenter or ServicePoint
- Fast replacement with exchange products in mint condition
- Advice on the most cost-efficient and quickest solution

Detailed information, addresses and forms at: www.pfeiffer-vacuum.com (Service).

Maintenance and repair in the Pfeiffer Vacuum ServiceCenter

The following steps are necessary to ensure a fast, smooth servicing process:

- Download the forms "Service Request" and "Declaration on Contamination".¹⁾
- Fill out the "Service Request" form and send it by fax or e-mail to your Pfeiffer Vacuum service address.
- Include the confirmation on the service request from Pfeiffer Vacuum with your shipment.
- Fill out the declaration on contamination and include it in the shipment (required!).
- Dismantle all accessories.
- Drain the operating fluid (applies for turbopumps with pumping speed > 800 l/s).
- Leave electronic drive on the pump.
- Close the flange openings by using the original protective covers.
- If possible, send pump or unit in the original packaging.

Sending of contaminated pumps or devices

No units will be accepted if they are contaminated with micro-biological, explosive or radioactive substances. "Hazardous substances" are substances and compounds in accordance with the hazardous goods directive (current version). If pumps are contaminated or the declaration on contamination is missing, Pfeiffer Vacuum performs decontamination at the shipper's expense.

- Neutralise the pump by flushing it with nitrogen or dry air.
- Close all openings airtight.
- Seal the pump or unit in suitable protective film.
- Return the pump/unit only in a suitable and sturdy transport container and send it in while following applicable transport conditions.

Exchange unit

The factory operating parameters are always preset with exchange units. If you use changed parameters for your application, you have to set these again.

Service orders

All service orders are carried out exclusively according to our repair conditions for vacuum units and components.

¹⁾ Forms under www.pfeiffer-vacuum.com

11 Spare parts HiPace 60 P

Item	Designation	Size	Order number	Notes	Pieces
9	Electronic drive unit TC 110		according to the rating plate	depends on the connection panel	1
40	Operating fluid reservoir		PM 143 740 -T	incl. Poroplast rods	1
320	Rubber foot	d = 12 mm	P 3695 700 ZD		4

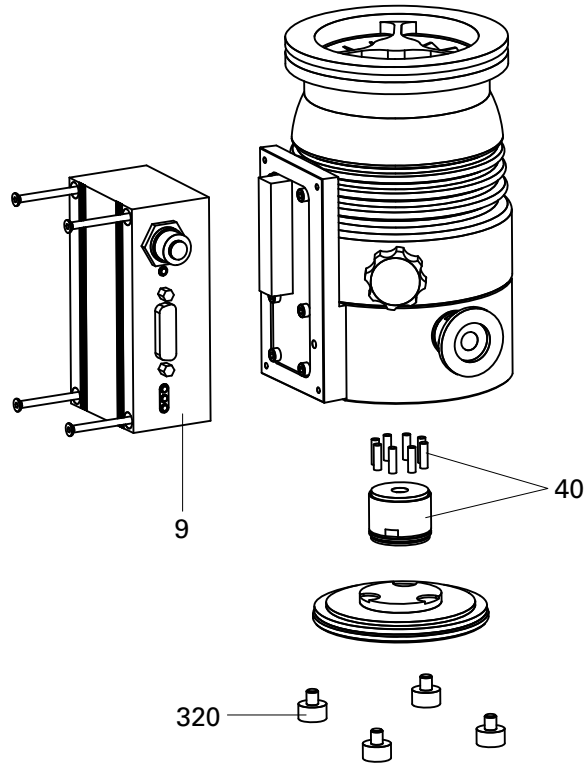

Please also specify model number of the the rating plate when ordering accessories or spare parts.

12 Accessories

Designation	HiPace® 60 P with TC 110, DN 63 ISO-K
TPS 110, mains pack for wall/standard rail fitting	PM 061 340 -T
TPS 180, mains pack for wall/standard rail fitting	PM 061 341 -T
TPS 111, mains pack 19" rack module 3HU	PM 061 344 -T
TPS 181, mains pack 19" rack module 3HU	PM 061 345 -T
Front panel kit for TPS 111	PM 061 393 -T
DCU 110, Display control unit incl. power supply	PM C01 820
DCU 180, Display control unit incl. power supply	PM C01 821
DCU 002, Display control unit	PM 061 348 -T
HPU 001, handheld programming unit	PM 051 510 -T
Accessories package for HPU - Power supply, software and PC cable	PM 061 005 -T
Mains cable 230 V AC with safety plug, Euro socket C13 (straight), 3 m	P 4564 309 ZA
Mains cable 115 V AC with UL plug, Euro socket C 13 (straight), 3 m	P 4564 309 ZE
Mains cable 208 V AC with UL plug, Euro socket C 13 (straight), 3 m	P 4564 309 ZF
Connection cable for HiPace with TC 110 and RS-485 interface to power supply TPS/DCU 110/111/180/181	PM 061 350 -T
Connection cable for HiPace with TC 110 and RS-485 interface and 2 accessory ports to power supply TPS/DCU 110/111/180/181	PM 061 351 -T
Venting valve, shielded, 24 V DC, G 1/8", for connection to TC 110	PM Z01 290
TTV 001, air drier for venting turbopumps	PM Z00 121
Air cooling for SplitFlow 50, HiPace 60/80 with TC 110	PM Z01 300
Water cooling for HiPace 60/80 for plug-in connection 8 mm	PM 016 623 -T
Relay box, shielded, for backing pumps, 1-phase 7A for TC 110 and TCP 350, M8	PM 071 282 -X
Backing pump relay box, single phase 20 A, for TC 110 and TCP 350, M8 plug	PM 061 373 -T
TVV 001 fore-vacuum safety valve, 230 V AC	PM Z01 205
TVV 001 fore-vacuum safety valve, 115 V AC	PM Z01 206
Sealing gas valve, shielded for HiPace 60/80 with TC 110	PM Z01 310
Sealing gas throttle for HiPace 60/80	PM Z01 316
Centering ring with multifunction coating, DN 63 ISO-K/-F	PM 016 206 -U
Centering ring with multifunction coating and integrated protection screen, DN 63 ISO-K/-F	PM 016 208 -U
Centering ring with multifunction coating and integrated splinter shield, DN 63 ISO-K/-F	PM 016 207 -U
Vibration damper for HiPace 60/80, DN 63 ISO-K	PM 006 800 -X
USB converter to RS-485 interface	PM 061 207 -T
Interface cable, M12 m straight / M12 m straight, 3.0 m	PM 061 283 -T
Y-Connector M12 to RS-485	P 4723 010
HiPace-ACP connection cable	PM 071 142 -X
TCS 11, adapter for TC 110 with interface RS-485	PM 061 636 -U
TCS 12, adapter for TC 110 with interface RS-485, 4 accessory ports and coupling set	PM 061 638 -U
TCS 15 for controlling backing pumps	PM 061 685 -X
Mounting kit for HiPace 60/80, DN 63 ISO-K, including coated centering ring and bracket screws	PM 016 360 -T
Mounting kit for HiPace 60/80, DN 63 ISO-K, including coated centering ring, protection screen and bracket screws	PM 016 362 -T
Mounting kit for HiPace 60/80 with DN 63 ISO-K, including coated centering ring, splinter shield and bracket screws	PM 016 361 -T
Mounting kit for HiPace 60/80, DN 63 ISO-K, including coated centering ring and claws	PM 016 510 -T
Mounting kit for HiPace 60/80, DN 63 ISO-K, including coated centering ring with integrated protection screen and claws grips	PM 016 512 -T
Mounting kit for HiPace 60/80, DN 63 ISO-K to DN 63 ISO-F, including coated centering ring, splinter and claw grips	PM 016 511 -T

13 Technical data and dimensions

13.1 General

Basic principles for the Technical Data of Pfeiffer Vacuum Turbopumps:

Maximum values refer exclusively to the input as a single load.

- Recommendations of PNEUROP committee PN5
- ISO 21360; 2007: "Vacuum technology - Standard methods for measuring vacuum-pump performance - General description"
- ISO 5302; 2003: "Vacuum technology - Turbomolecular pumps - Measurement of performance characteristics"
- Ultimate pressure: using a test dome and a 48 hrs. period of baking out
- Gas throughput: water cooling; backing pump = rotary vane pump (10 m³/h)
- Cooling water consumption: at max. gas throughput, cooling water temp. 25 °C
- Integral leak rate: using a Helium concentration of 100 %, period 10 s
- Sound pressure level: Distance 1 m to the pump

Conversion table: pressure units

	mbar	bar	Pa	hPa	kPa	Torr mm Hg
mbar	1	$1 \cdot 10^{-3}$	100	1	0.1	0.75
bar	1000	1	$1 \cdot 10^5$	1000	100	750
Pa	0.01	$1 \cdot 10^{-5}$	1	0.01	$1 \cdot 10^{-3}$	$7.5 \cdot 10^{-3}$
hPa	1	$1 \cdot 10^{-3}$	100	1	0.1	0.75
kPa	10	0.01	1000	10	1	7.5
Torr mm Hg	1.33	$1.33 \cdot 10^{-3}$	133.32	1.33	0.133	1

1 Pa = 1 N/m²

Conversion table: gas throughput units

	mbar l/s	Pa m ³ /s	sccm	Torr l/s	atm cm ³ /s
mbar l/s	1	0.1	59.2	0.75	0.987
Pa m ³ /s	10	1	592	7.5	9.87
sccm	$1.69 \cdot 10^{-2}$	$1.69 \cdot 10^{-3}$	1	$1.27 \cdot 10^{-2}$	$1.67 \cdot 10^{-2}$
Torr l/s	1.33	0.133	78.9	1	1.32
atm cm ³ /s	1.01	0.101	59.8	0.76	1

13.2 Technical data

Parameter	HiPace [®] 60 P
Flange (in)	DN 63 ISO-K
Flange (out)	DN 16 ISO-KF / G 1/4"
Pumping speed for Ar	63 l/s
Pumping speed for H ₂	28 l/s
Pumping speed for He	48 l/s
Pumping speed for N ₂	64 l/s
Compression ratio for Ar	$2 \cdot 10^6$
Compression ratio for H ₂	$2 \cdot 10^2$
Compression ratio for He	$3.5 \cdot 10^2$
Compression ratio for N ₂	$1 \cdot 10^6$
Gas throughput at full rotational speed for Ar	0.83 hPa l/s
Gas throughput at full rotational speed for He	55 hPa l/s
Gas throughput at full rotational speed for H ₂	55 hPa l/s
Gas throughput at full rotational speed for N ₂	9.2 hPa l/s
Fore-vacuum max. for Ar	0.9 hPa
Fore-vacuum max. for H ₂	12 hPa

Parameter	HiPace® 60 P
Fore-vacuum max. for He	12 hPa
Fore-vacuum max. for N ₂	4 hPa
Run-up time	1.1 min
Ultimate pressure according to PNEUROP	< 1 · 10 ⁻⁶ hPa
Rotation speed ± 2 %	90000 min ⁻¹
Rotation speed variable	50-100 %
Power characteristic line in gas mode 1, vertex A	58/90000 W/min ⁻¹
Power characteristic line in gas mode 1, vertex B	64/81000 W/min ⁻¹
Power characteristic line in gas mode 0, vertex C	28/90000 W/min ⁻¹
Power characteristic line in gas mode 0, vertex D	38/81000 W/min ⁻¹
Power characteristic line in gas mode 2, vertex E	58/90000 W/min ⁻¹
Power characteristic line in gas mode 2, vertex F	64/81000 W/min ⁻¹
Sound pressure level	≤ 48 dB (A)
Relative humidity of air	5-85, non-condensing %
Protection category	IP 54
Connection pressure max. for venting/sealing gas valve	1500 hPa
Operating voltage	24 (± 5 %) V DC
Operating voltage power supply	90-265 V AC
Integral leak rate	< 1 · 10 ⁻⁸ Pa m ³ /s
Power consumption max.	110 W
Current consumption max.	4.6 A
Shipping and storage temperature	-25-+55 °C
Mounting orientation	in any orientation
Venting connection	G 1/8"
Weight	2.2 kg
Cooling method, standard	Convection
Cooling method, optional	Air/water
Cooling water temperature	5-25 °C
Cooling water consumption	75 l/h
Permissible irradiated thermal power max.	1.2 W
Permissible magnetic field max.	4 mT
Interfaces	RS-485, Remote

13.3 Dimensions

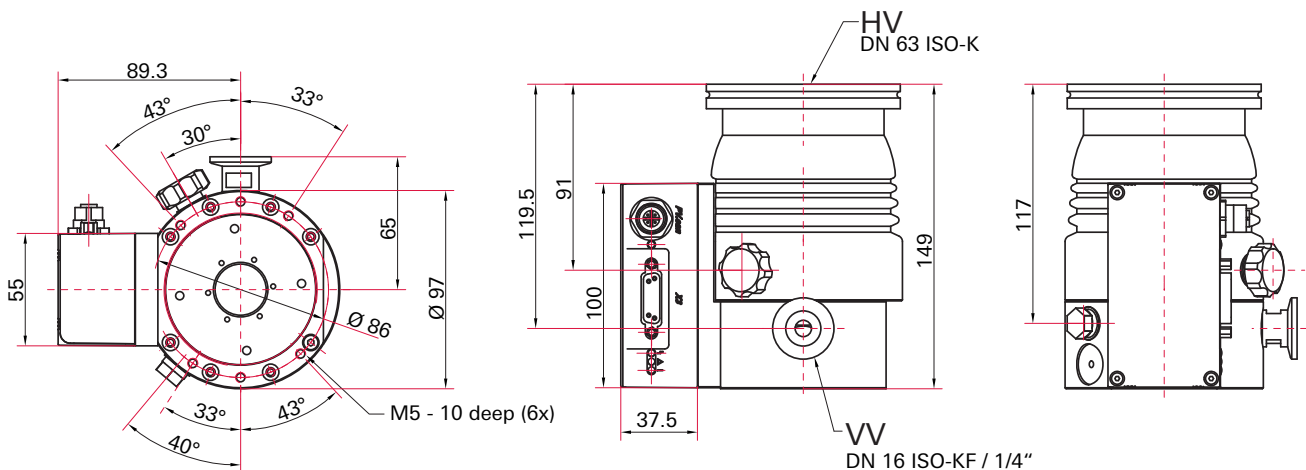

Fig. 15: HiPace 60 P, DN 63 ISO-K



Declaration of conformity

We hereby declare that the product cited below satisfies all relevant provisions according to the following **EC directives**:

- **Machinery 2006/42/EC (Annex II, no. 1 A)**
- **Electromagnetic Compatibility 2004/108/EC**

The agent responsible for compiling the technical documentation is Mr. Helmut Bernhardt, Pfeiffer Vacuum GmbH, Berliner Straße 43, 35614 Asslar.

HiPace 60 P

Harmonised standards and national standards and specifications which have been applied:

DIN EN ISO 12100 : 2011-03
DIN EN 1012-2 : 1996
DIN EN 61010-1 : 2011

Signatures:

Pfeiffer Vacuum GmbH
Berliner Straße 43
35614 Asslar
Germany

(M. Bender)
Managing Director

(Dr. M. Wiemer)
Managing Director

CE/2013

**Vacuum solutions
from a single source**

Pfeiffer Vacuum stands for innovative and custom vacuum solutions worldwide, technological perfection, competent advice and reliable service.

**Complete range
of products**

From a single component to complex systems: We are the only supplier of vacuum technology that provides a complete product portfolio.

**Competence in
theory and practice**

Benefit from our know-how and our portfolio of training opportunities! We can support you with your plant layout and provide first-class on-site-service worldwide.

**Are you looking for a
perfect vacuum solution?
Please contact us**

Pfeiffer Vacuum GmbH
Headquarters • Germany
T +49 6441 802-0
info@pfeiffer-vacuum.de