

---

---

# Turbo Molecular Pump

## STP-A803/A1303 series

### Specification

---

---

#### Pump Type

- STP-A803C
- STP-A1303C
- STP-A803CV
- STP-A1303CV

## TABLE OF CONTENTS

<b>1</b>	<b>Introduction</b> .....	<b>2</b>
1.1	Application .....	2
1.2	Configuration.....	3
<b>2</b>	<b>STP pump</b> .....	<b>4</b>
2.1	STP pump specification .....	4
2.2	Precaution before installing the STP pump.....	5
2.2.1	How to secure the STP pump.....	5
2.2.2	Purge gas for STP pump.....	6
<b>3</b>	<b>STP control unit specification</b> .....	<b>7</b>
<b>4</b>	<b>Power cable specification</b> .....	<b>8</b>
<b>5</b>	<b>STP connection cable specification</b> .....	<b>8</b>
<b>6</b>	<b>TMS unit specification</b> .....	<b>9</b>
6.1	TMS connection cable .....	9
6.2	TMS sensor cable .....	9
6.3	TMS valve (with cable) .....	9
<b>7</b>	<b>STP pump detailed specification</b> .....	<b>10</b>
7.1	Pumping speed graph.....	10
7.2	Throughput graph (P-Q curve) .....	11
7.3	STP pump external views .....	12
<b>8</b>	<b>STP control unit detailed specification</b> .....	<b>16</b>
8.1	I/O Remote.....	16
8.2	RS232/RS485 .....	17
<b>9</b>	<b>Attachment component</b> .....	<b>17</b>
<b>10</b>	<b>Accessory</b> .....	<b>17</b>

## PRECAUTIONS

- 1) No part of this documents may be reproduced and transmitted in any means without prior written permission from Edwards.
- 2) Edwards pursues a policy of continuing improvement in design and performance of this product. The right is, therefore, reserved to vary specifications and design without notice. Understand that the product you purchased and its contents including specifications described in this manual may differ.

## 1 Introduction

Turbo Molecular pump is one of the most important Vacuum Components in the most-advanced technologies field like Semiconductor and LCD manufacturing tools, high-energy physics, etc.

This document describes the standard specification for the magnetically levitated turbo molecular pumps of STP-A803C/A1303C and STP-A803CV/A1303CV.

- STP-A803C/A1303C is one of A (Advanced high throughput) series turbomolecular pump and has features of high throughput performance.
- STP-A803CV/A1303CV is one of A series turbomolecular pump with TMS<sup>\*1</sup> in order to reduce the deposition inside the pump from by-products.

\*1: TMS (Temperature Management System) keeps the pump inside temperature high. TMS controls the pump temperature based on TMS sensor information in order to make ON/OFF control of TMS heater band and TMS water control valve. If by-products deposition is expected, Edwards recommends the customer to use TMS Unit as an option.

### 1.1 Application

Semiconductor / LCD manufacturing tools like Dry Etching, CVD, Sputtering, Ion implantation, etc.

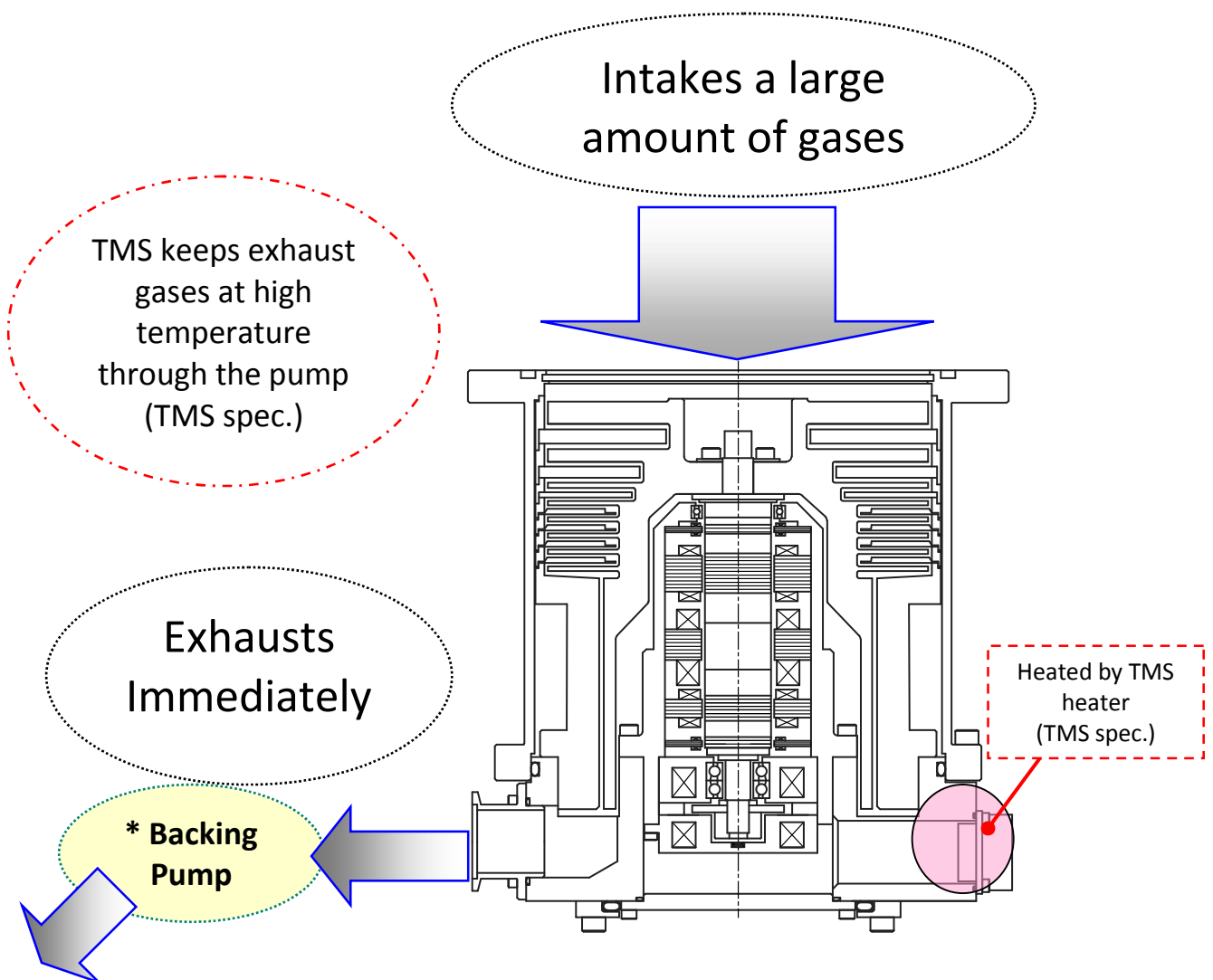

\* The backing pump is needed to operate the turbomolecular pump.

## 1.2 Configuration

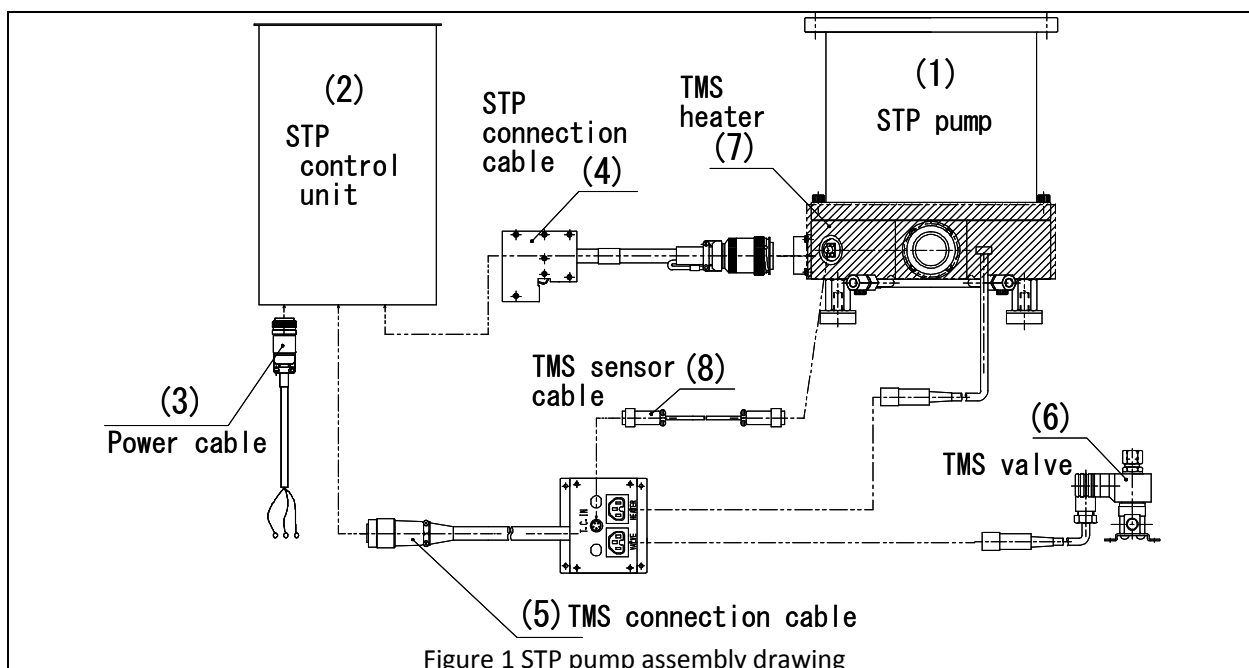

Figure 1 STP pump assembly drawing

Item	Q'ty	Description	Need to specify at order
(1) STP pump	1	Please select pump type and inlet flange type according to the customer specifications. See the chapter 2.1 for the pump specifications. If the TMS is required, select STP-A803CV or STP-A1303CV (CV version).	- Inlet flange type - TMS option
(2) STP control unit	1	The control unit has a remote function to communicate with the customer tool. The controller accepts Start/Stop commands and delivers the pump operating status (Levitation, Normal, Alarm etc)	
(3) Power cable	1	Power cable to supply AC power to the controller. Please specify the cable length to order. (5 m/10 m/15 m/20 m)	- Cable length
(4) STP connection cable	1	The connection cable between STP pump and STP control unit. Straight-shape type and L-shape type are available on the pump side connector. Please specify the angle for the L-shape connector to order. (0° / 90°) Please specify the cable length to order. (5 m/10 m/15 m/20 m)	- Connector type (Angle for L-type connector) - Cable length
The parts under this line, (5) to (8), are needed for STP-A803CV/A1303CV which have TMS.			
(5) TMS connection cable	1	This cable is to connect between TMS heater, TMS water control valve, TMS sensor and the control unit. Please specify the cable length to order. (5 m/10 m/15 m/20 m)	- Cable length
(6) TMS valve (with cable)	1	Cool down the pump with ON/OFF control of cooling water.	
(7) TMS heater	1	Heat up the pump with ON/OFF control.	
(8) TMS sesor cable	1	Connection cable for TMS sensor.	

\* Use the STP selection sheet at the end of this document when you order our pumps.

## 2 STP pump

### 2.1 STP pump specification

Pump Type		STP-A803C	STP-A1303C	STP-A803CV	STP-A1303CV
TMS unit		Without TMS		With TMS	
Flange size	Inlet port flange	ICF203/VG150 ISO160F	ICF253VG200 ISO200F	ICF203/VG150 ISO160F	ICF253VG200 ISO200F
	Outlet port flange	KF40			
	Purge port flange	KF10			
Pumping speed (L/s) <sup>*1</sup> (see chapter 7.1)	N <sub>2</sub>	800	1300	800	1300
	H <sub>2</sub>	520	800	520	800
Compression ratio <sup>*1</sup>	N <sub>2</sub>	> 10 <sup>8</sup>			
	H <sub>2</sub>	10 <sup>3</sup>			
Allowable maximum continuous flow rate <sup>*1,*2</sup> (sccm)	N <sub>2</sub>	1500		1000	
Ultimate pressure <sup>*1,*3</sup>	Pa	10 <sup>-7</sup> (10 <sup>-9</sup> Torr) order			
Allowable maximum backing pressure <sup>*1</sup>	Pa	270 (2 Torr)			
Enable exhaust gas	Chlorine and Fluorine gas can be used. When you want to use the following gas, please contact Edwards. <ul style="list-style-type: none"> <li>- The gas including alkali metal, but except "Li".</li> <li>- The gas including "Ga", "Hg", "In" and "Sn".</li> <li>- HBr</li> </ul>				
Purge gas flow rate	sccm	20 (see chapter 2.2.2)			
Back pump size	L/min	> 1300			
Rated speed	rpm	32,500 (Allowable speed range: between 16,000 and 32,500)			
Starting time	min	7			
Stopping time	min	8			
Baking temperature	°C	< 120		No baking possible with TMS	
Lubricating oil	Not necessary				
Installation position	Free				
Cooling method	Water cooling		Water cooling controlled by TMS		
TMS temperature setting	°C	-		60	
Water Cooling	Flow rate	L/min	2		
	Temperature	°C	5 to 25		
	Pressure	Mpa	< 0.3		
Water cooling fitting	Size	Rc 1/4 (ISO standard)			
	Material	Brass			
Mass	kg	39			
Dimension	mm	See chapter 7.3 Pump Overview Chart			
Ambient air temp. range	°C	0 to 40			
Storage temp. range	°C	-25 to 55			
Connection cable length	m	30 (maximum)			

The data inside above table are the typical measured value. It's not guaranteed performance.

\*1: Pumping speed, compression ratio, allowable maximum continuous flow rate, ultimate pressure and allowable maximum backing pressure are measured by Edwards method

\*2: Allowable maximum continuous flow rate varies depend on the cooling methods. The pumping speed of 1,300 (L/min) dry pump was used for the measurements.

\*3: Ultimate pressure is a value after baking.

## 2.2 Precaution before installing the STP pump

### 2.2.1 How to secure the STP pump

The STP pump has a high-speed rotor. The worst-case failure may result in a jump in rotational torque leading to personal injury or equipment damages.

The generated torque during a pump failure is called "Destructive torque". Design and secure the mounting for the STP pump on the tools in order to withstand this destructive torque. Refer to Table 2.1 for destructive torque values and recommended bolts. All flange bolts size should be the size specified by the flange standard. And it is necessary to use all flange holes in order to secure the STP pump mounting.

Table 2.1 (a) Destructive torque and recommended bolts

For flange secured only

Pump type	STP-A803			STP-A1303		
Flange type	VG150	ISO160F	ICF203	VG200	ISO200F	ICF253
Destructive torque [Nm]	$3.0 \times 10^4$	$3.0 \times 10^4$	$3.0 \times 10^4$	$2.7 \times 10^4$	$2.6 \times 10^4$	$3.0 \times 10^4$
Base (8 positions) secured	Not available					
Recommended bolts for flange	Shape of bolts	M10 R.D.S.B <sup>*1</sup>		M8 Standard	M12 Standard	M10 Standard M8 Standard
	Q'ty	8	8	20	8	12 24
	Steel type <sup>*2</sup>	Carbon steel/Alloyed steel			Stainless steel	
	Strength class <sup>*2</sup>	Equivalent to AMS6419		12.9 or more	70 or more	

Table 2.1 (b) Destructive torque and recommended bolts

For flange secured + base secured

Pump type	STP-A803			STP-A1303		
Flange type	VG150	ISO160F	ICF203	VG200	ISO200F	ICF253
Destructive torque [Nm]	$3.0 \times 10^4$	$3.0 \times 10^4$	$3.0 \times 10^4$	$2.7 \times 10^4$	$2.6 \times 10^4$	$3.0 \times 10^4$
Base (8 positions) secured	Available					
Recommended bolts for flange	Shape of bolts	M10 Standard		M8 Standard	M12 Standard	M10 Standard M8 Standard
	Q'ty	8	8	20	8	12 24
	Steel type <sup>*2</sup>	Stainless steel				
	Strength class <sup>*2</sup>	70 or more				

Secure the base with all 8 screw-holes for legs or all 8 attached legs.

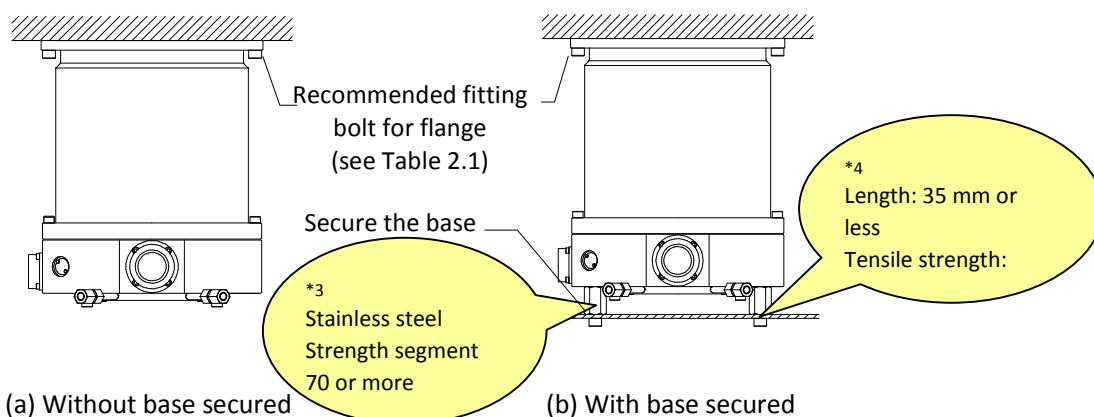

Figure 2.1 Methods of securing the STP pump using inlet flange holes

<sup>\*1</sup> Refer to Figure 2.2. Shape of Reduced Diameter Shank Bolts (=R.D.S.B.)

<sup>\*2</sup> JISB1051 (ISO898-1), JISB1054 (ISO3506), AMS6419 (Aerospace Material Specification).

<sup>\*3</sup> The length of the legs, when the customer would like to make, should be less than attached legs from Edwards. And the material tensile strength should be 600 N/mm<sup>2</sup> or more.

<sup>\*4</sup> The bolts for the base secure will be Stainless Steel with strength segment of 70 or more.

Reduced diameter shank bolts (R.D.S.B.) listed on Table 2.1 (a) are more reinforced bolts over standard bolts by smoothing the portion to attach flange securing bolts to the respective face at the equipment side. Refer to Figure 2.2 for shape of R.D.S.B.

Refer to the following figure for the shape of R.D.S.B.

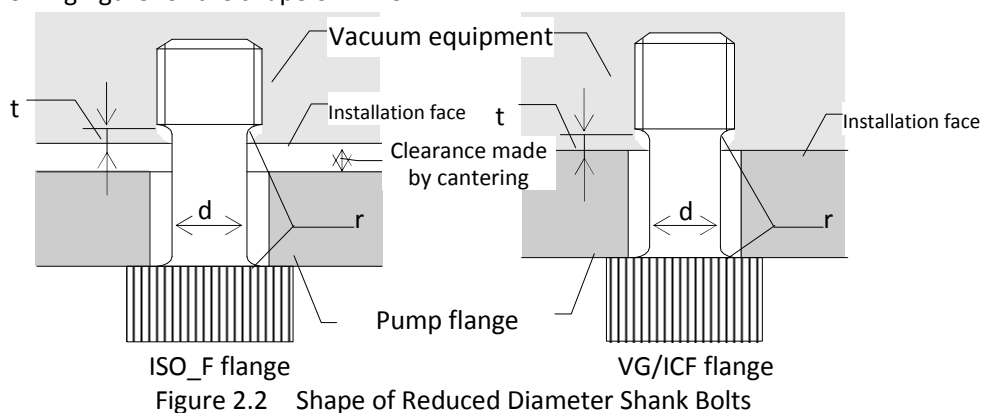

Figure 2.2 Shape of Reduced Diameter Shank Bolts

Bolt size	Type of flange	t	d	r
M8	ISO_F flange	2.5 mm or more	5.9 mm or more	0.8 mm or more
	ICF flange	1 mm or more		
M10	ISO_F flange	3 mm or more	7.5 mm or more	
	VG flange	1.5 mm or more		
M12	ISO_F flange	3.5 mm or more	9.1 mm or more	
	VG flange	2 mm or more		

## 2.2.2 Purge gas for STP pump

When pumping reactive or corrosive gases, introduce the dry N<sub>2</sub> gas or other gas in to the STP pump in order to protect the inside of the STP pump.

- ◇ Introduce dry N<sub>2</sub> or other gas into the pump through the purge port using the electromagnetic valve or the needle valve provided by the customer.
- ◇ Recommended Purge gas flow rate is  $3.4 \times 10^{-2}$  Pa · m<sup>3</sup>/s (20 sccm).
- ◇ The allowable gas pressure ranges from  $1.0 \times 10^5$  Pa (atmospheric pressure) to  $4.9 \times 10^4$  Pa (0.5 kgf/cm<sup>2</sup>) on the introduction side.
- ◇ High-pressure at the inlet port may result in a noise. This is no abnormality/error.

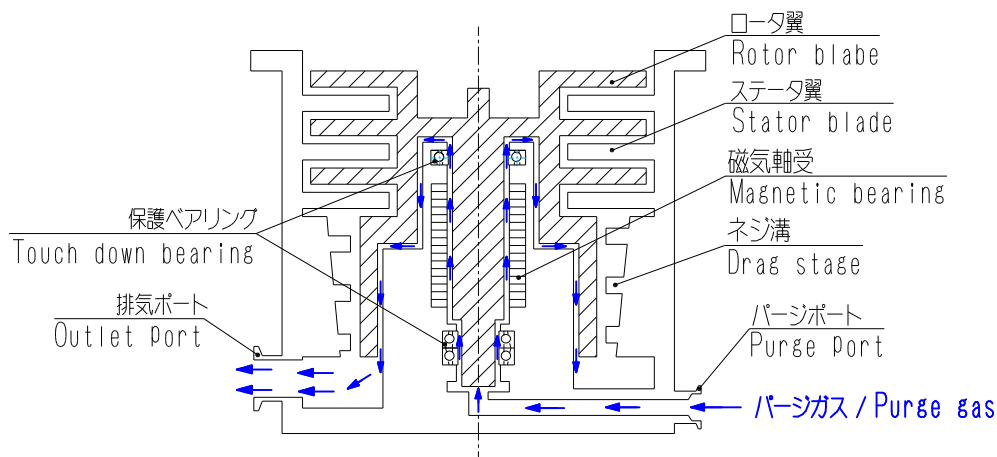
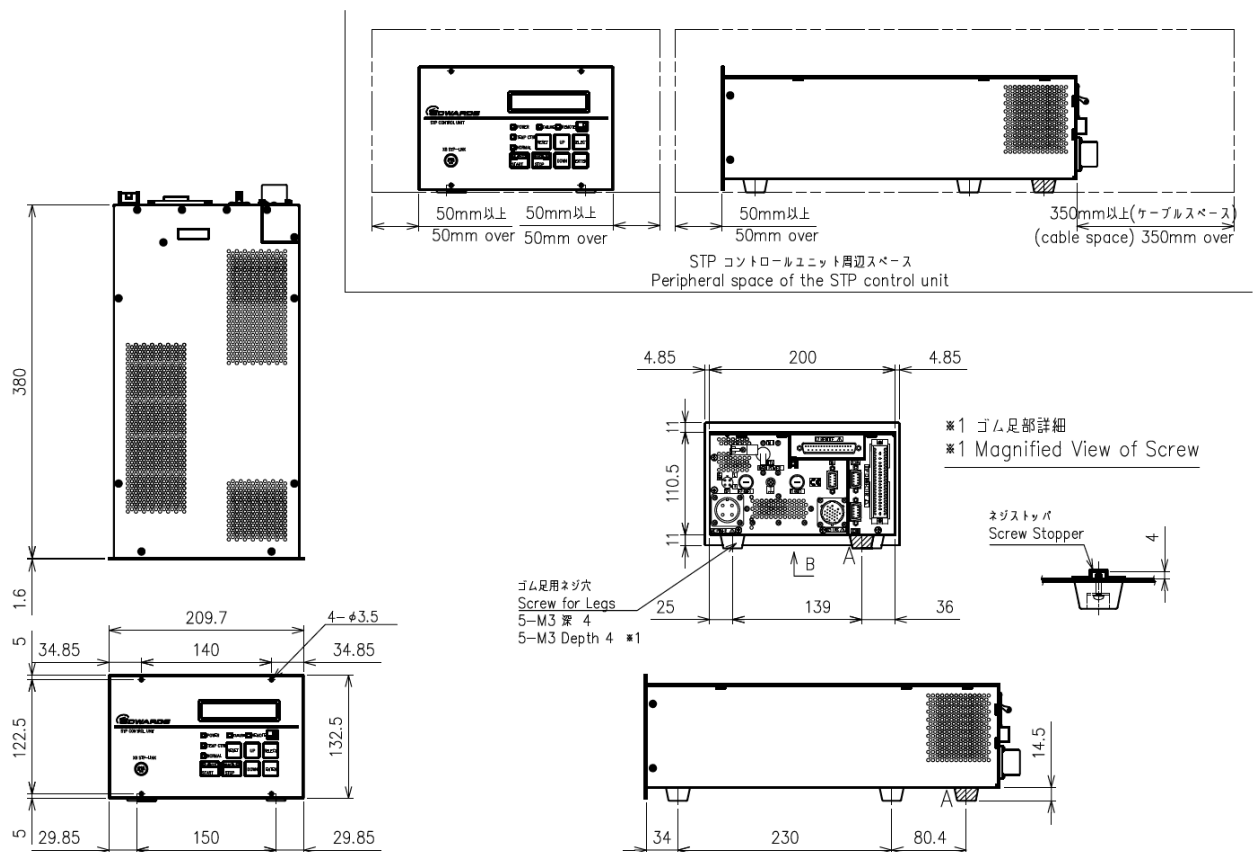

Figure 2.3 Purge gas flow inside the pump

### 3 STP control unit specification

Item		Specification	
Controller type		SCU-800	
Input voltage	Vac	200 to 240	
Input frequency	Hz	50/60+/-2	
Input phase		Single phase	
Input power (Maximum value)	Without TMS	VA	850
	With TMS	VA	1200
Inrush current		A	25 <sub>0-P</sub>
Leakage current		mA	3.5 or less
Main breaker	Rated current	A	15
	AIC: Ampere Interrupting Capacity	A	1000 (240 Vac: 50/60 Hz)
Allowable operating temperature		°C	0 to 40
Allowable storage temperature		°C	-25 to 55
Mass		kg	9
Remote interface		I/O Remote (see 8.1) RS232/RS485 (see 8.2)	



External view of STP control unit SCU-800



#### 4 Power cable specification

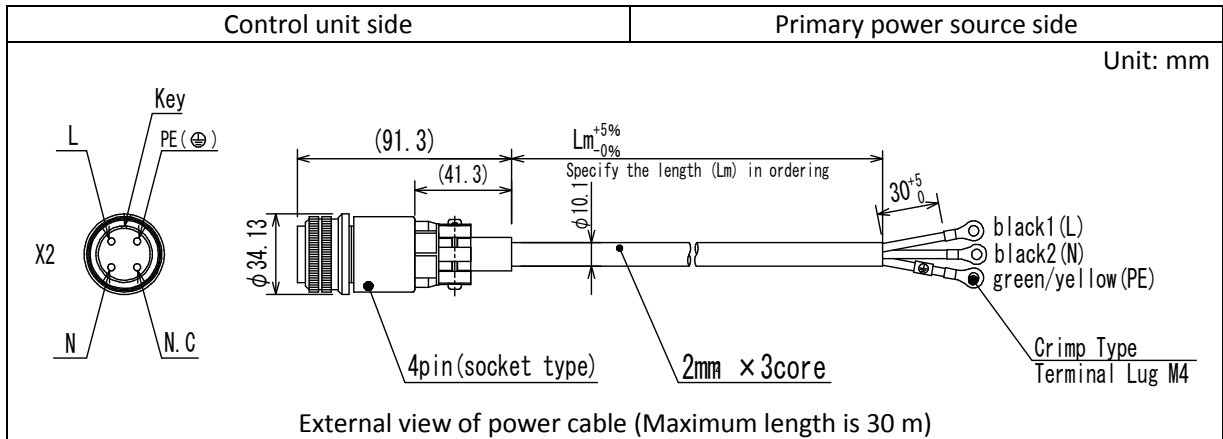

#### 5 STP connection cable specification

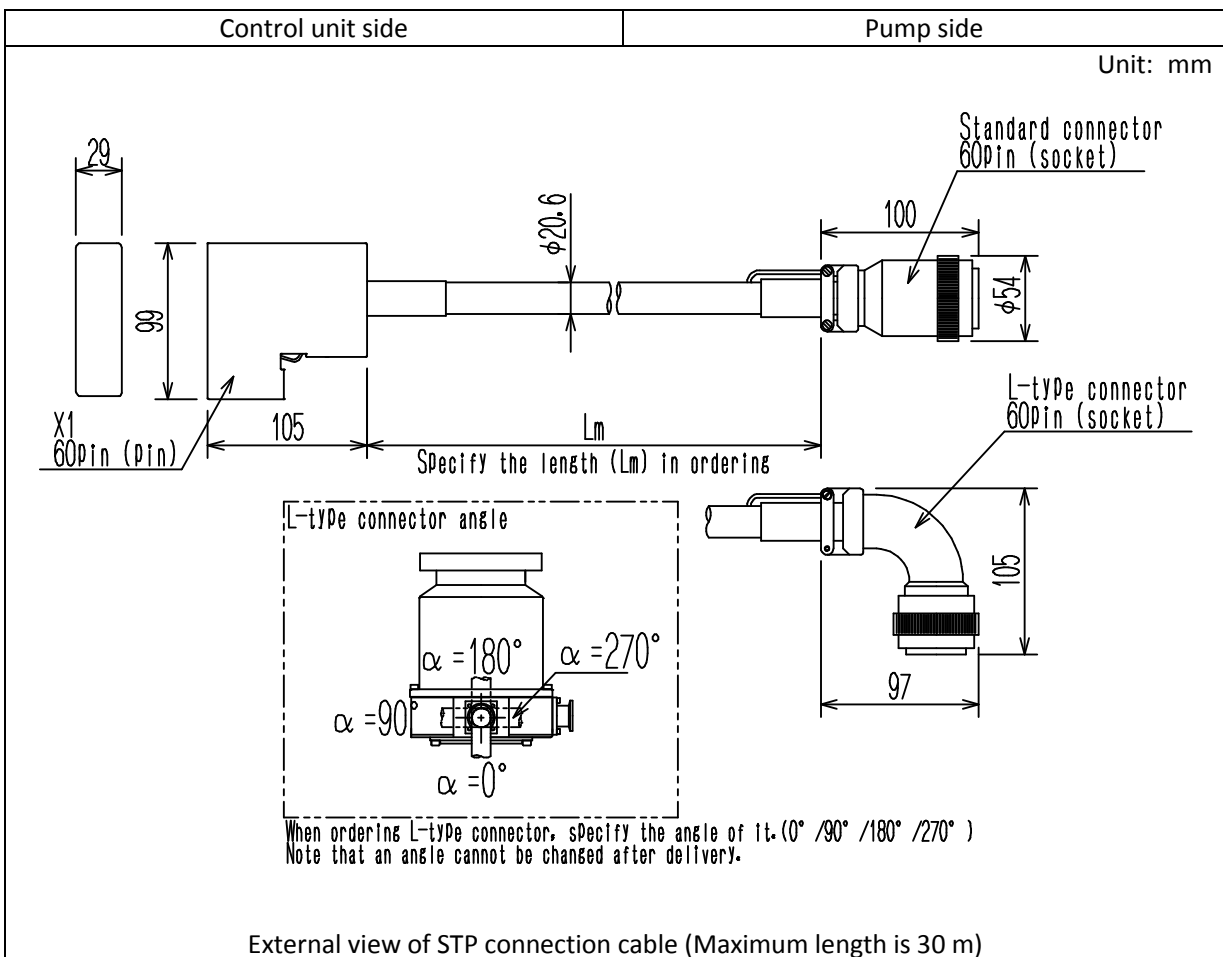

## 6 TMS unit specification

### 6.1 TMS connection cable

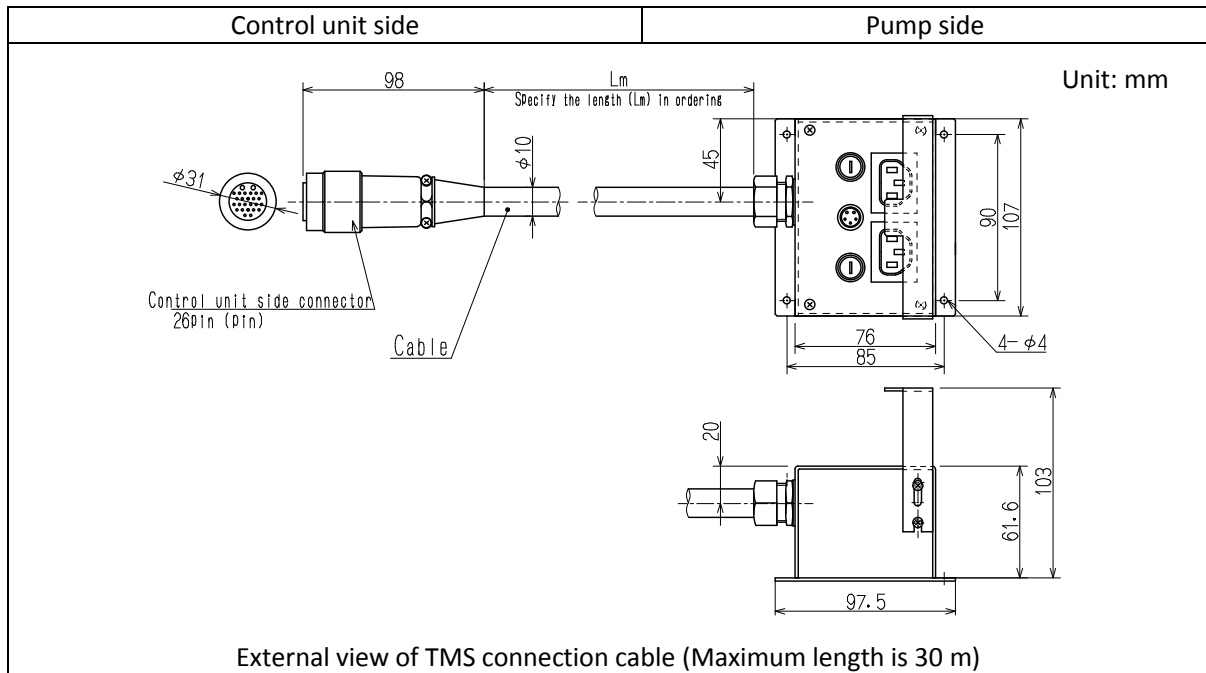

### 6.2 TMS sensor cable

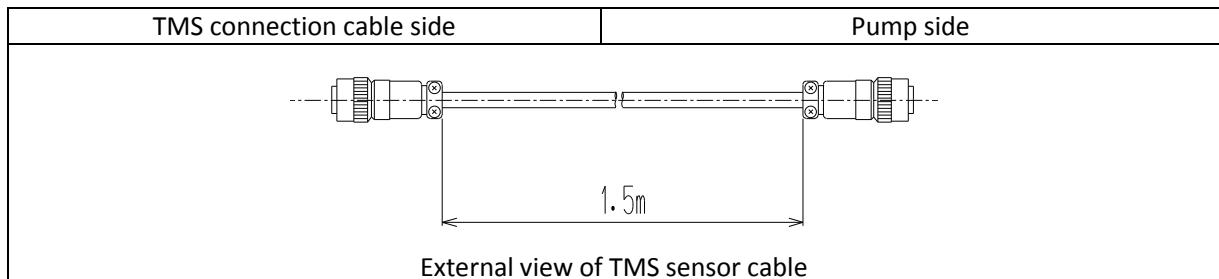

### 6.3 TMS valve (with cable)

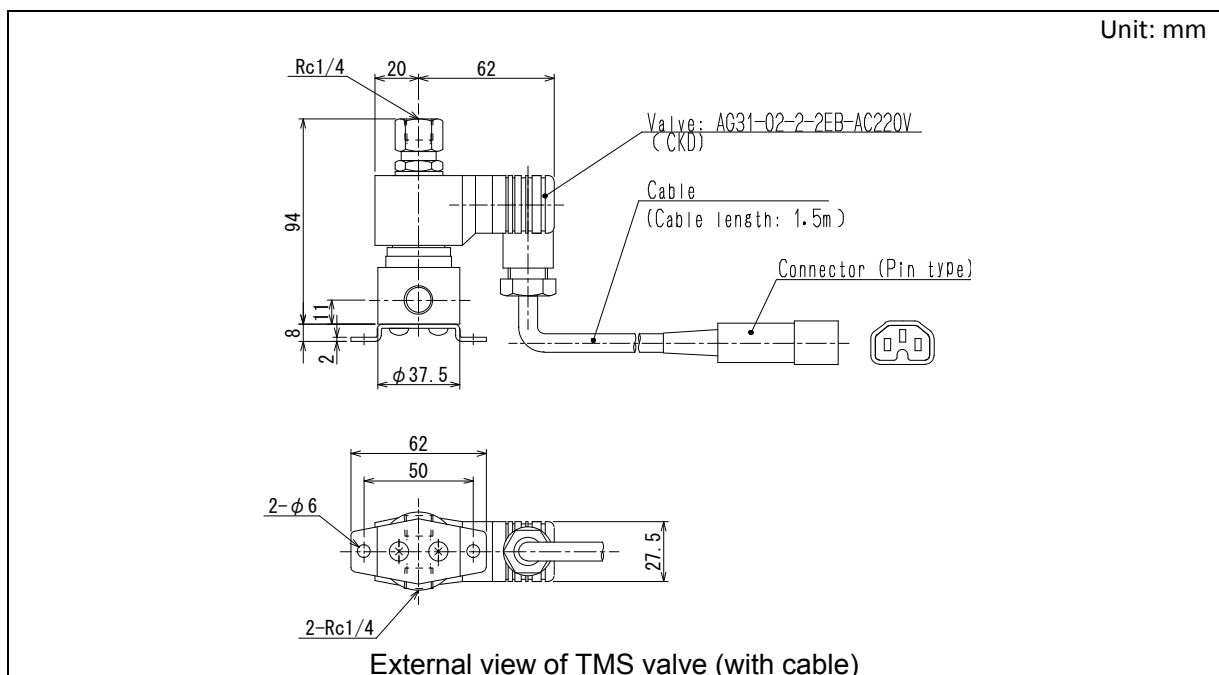

## 7 STP pump detailed specification

### 7.1 Pumping speed graph

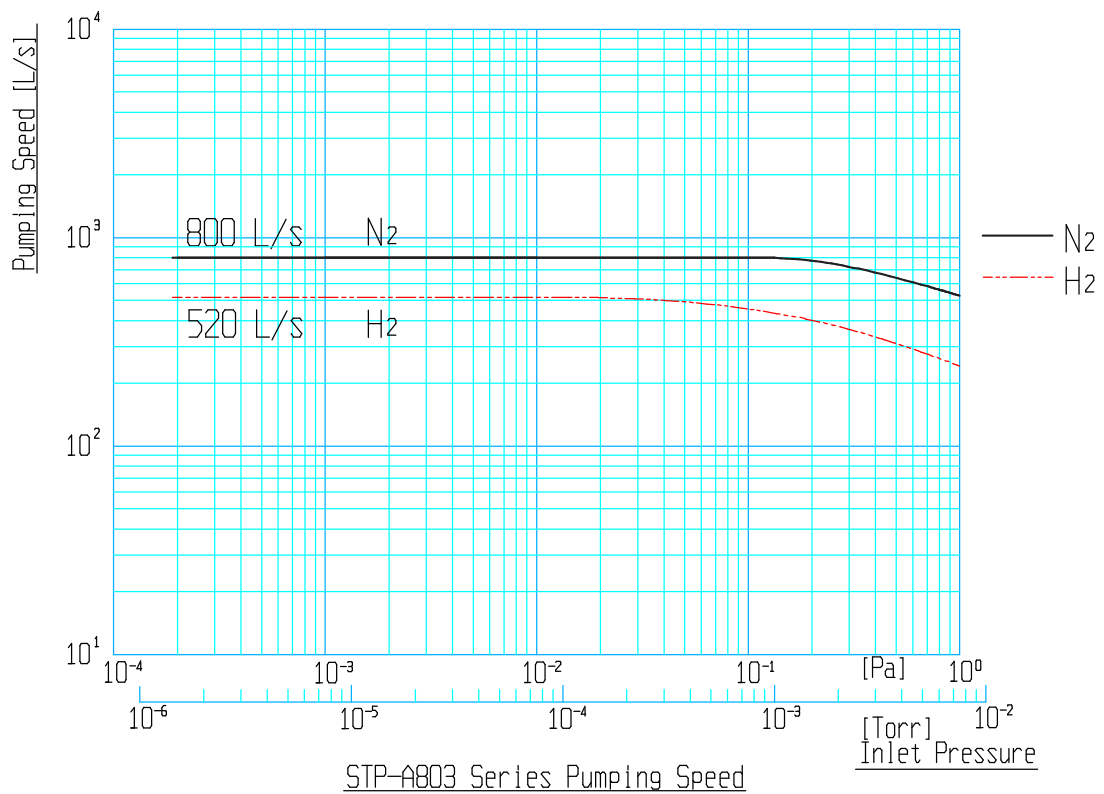

**Graph 1**

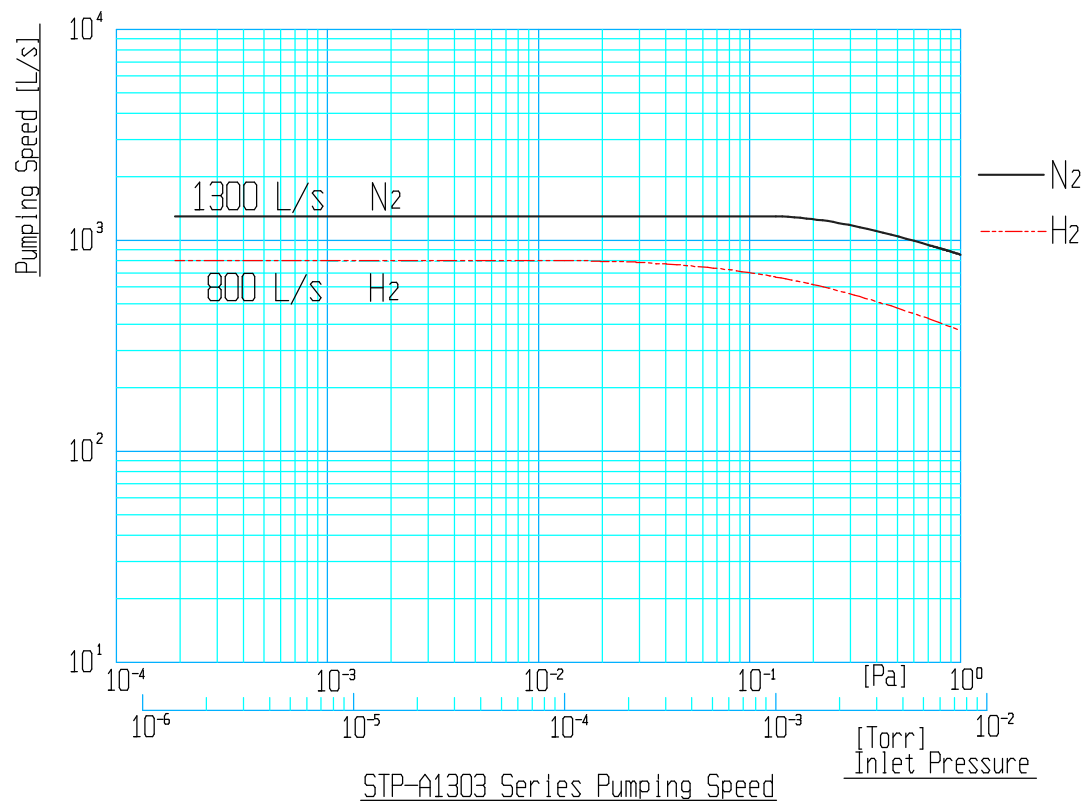

**Graph 2**

7.2 Throughput graph (P-Q curve)

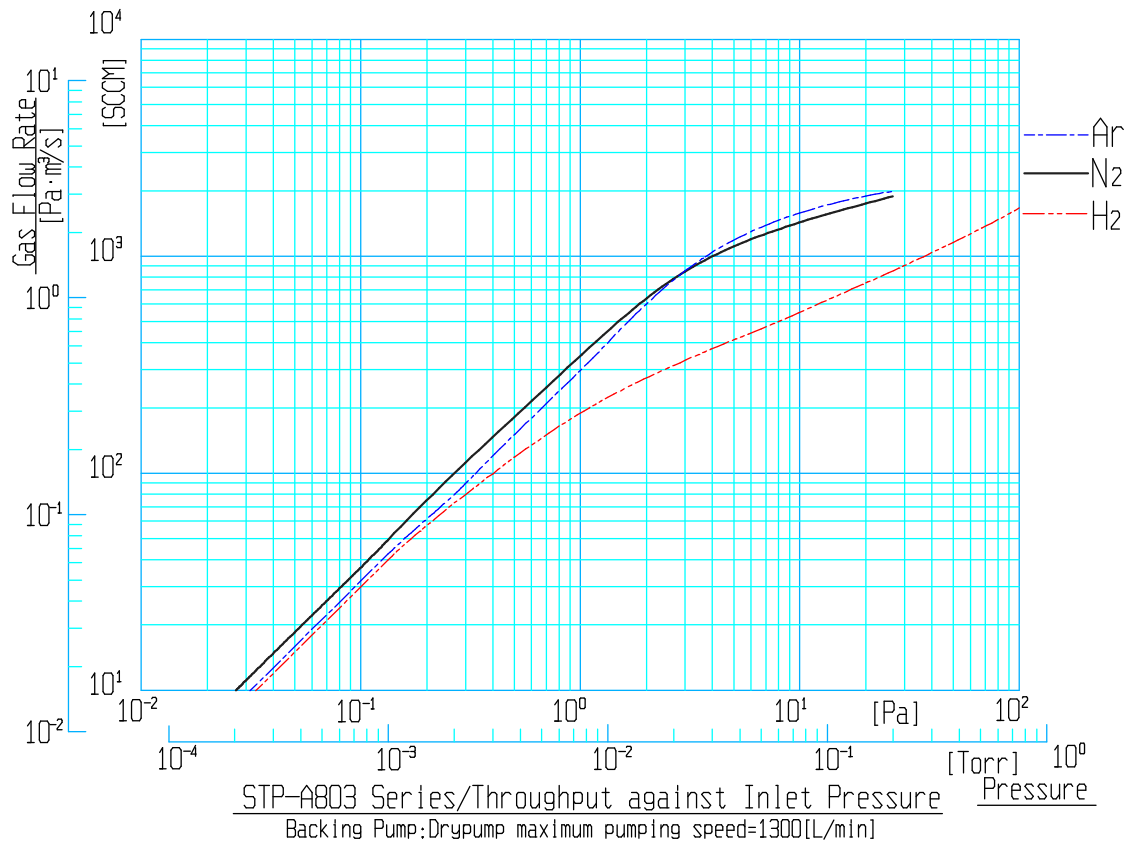

Graph 3

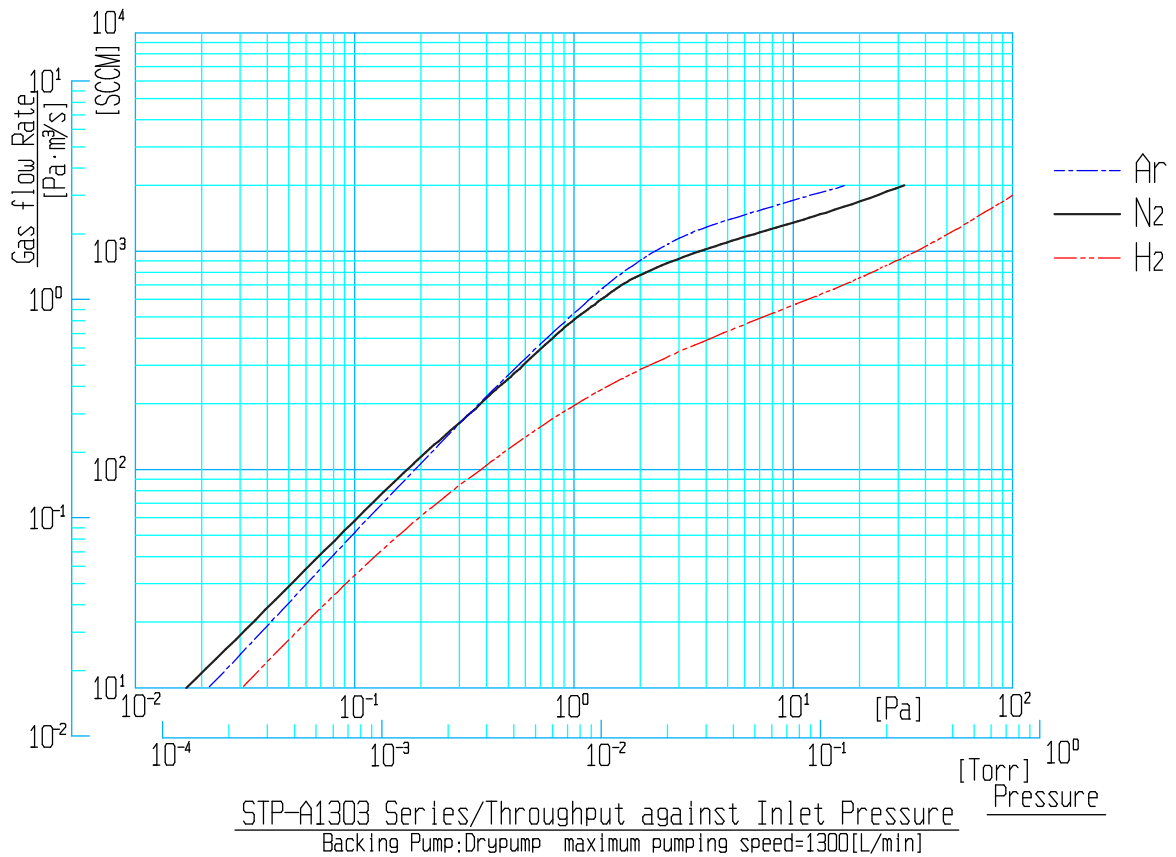

Graph 4

### 7.3 STP pump external views

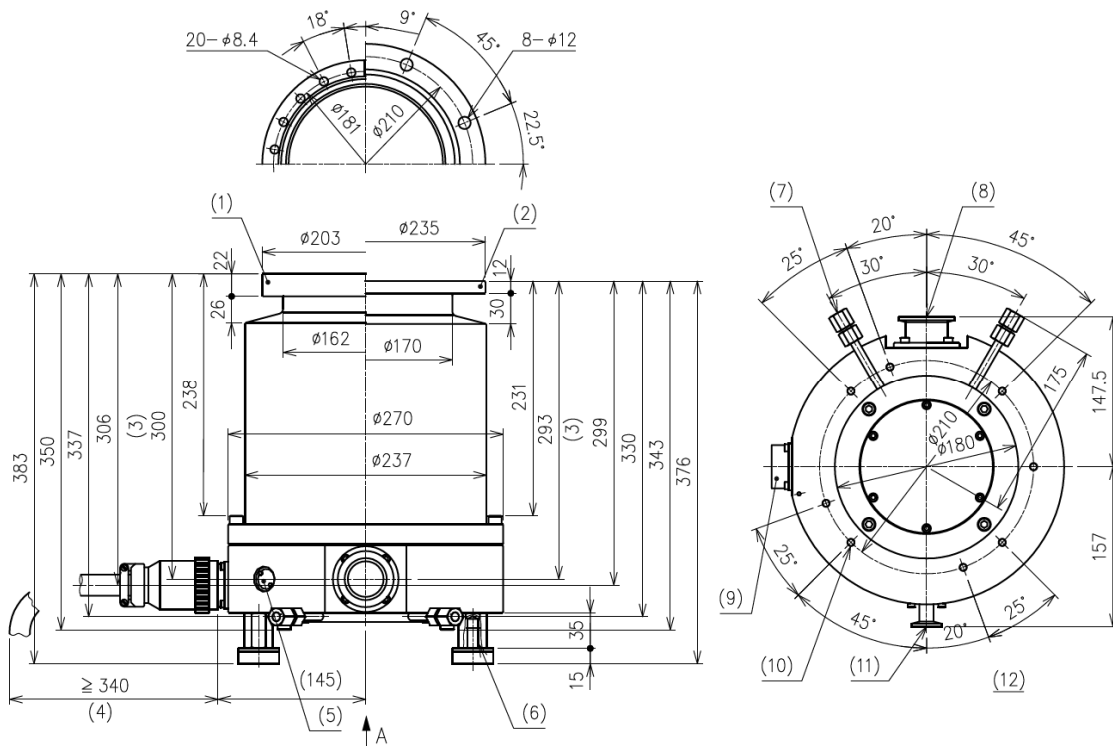

**STP-A803C (ICF203/VG150)**

No.	Item	Description
1	Inlet port flange	ICF <sup>*1</sup> 203
2	Inlet port flange	VG <sup>*2</sup> 150
3	Height of the purge port	
4	Bending dimension of the STP connection cable	
5	Temperature sensor connector	Optional accessory
6	Screw hole of legs	M12 <sup>*2</sup> depth 20
7	Cooling water port	2-Rc <sup>*3</sup> 1/4
8	Outlet port flange	KF <sup>*2</sup> 40
9	STP connector	
10	Screw hole for legs	8-M12 <sup>*2</sup> depth 24
11	Purge port	KF <sup>*2</sup> 10
12	Viewed from arrow A	

\*1 JVIS  
\*2 JIS  
\*3 ISO

## (7.3 Pump external views)

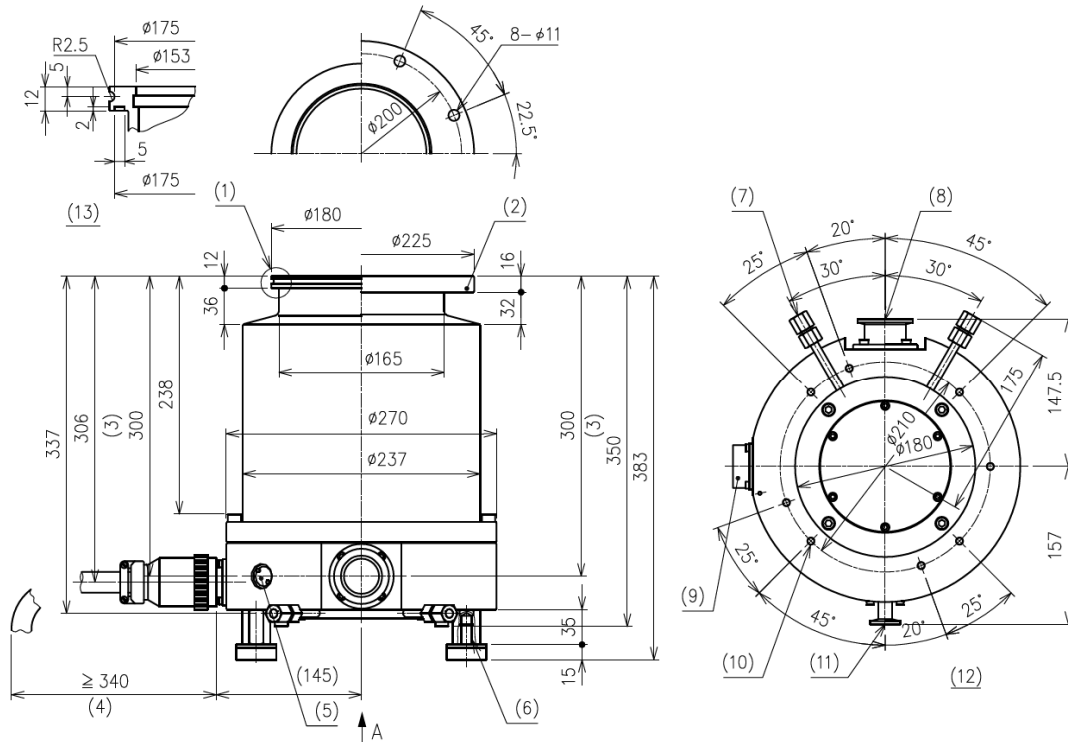
**STP-A803C (ISO160/ISO160F)**

No.	Item	Description
1	Inlet port flange	ISO <sup>*2</sup> 160
2	Inlet port flange	ISO <sup>*2</sup> 160F
3	Height of the purge port	
4	Bending dimension of the STP connection cable	
5	Temperature sensor connector	Optional accessory
6	Screw hole of legs	M12 <sup>*1</sup> depth 20
7	Cooling water port	2-Rc <sup>*2</sup> 1/4
8	Outlet port flange	KF <sup>*1</sup> 40
9	STP connector	
10	Screw hole for legs	8-M12 <sup>*1</sup> depth 24
11	Purge port	KF <sup>*1</sup> 10
12	Viewed from arrow A	
13	Magnified view of the inlet port flange	ISO160

\*1 JIS

\*2 ISO

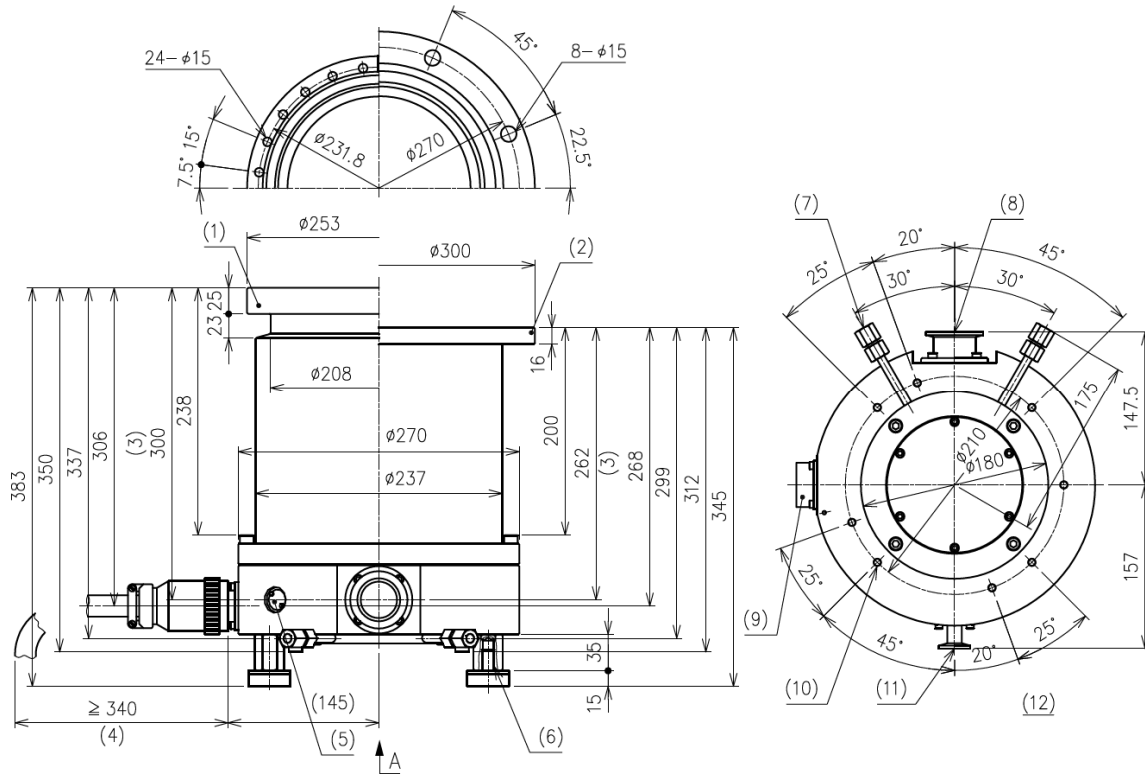

**STP-A803C (ICF253/VG200)**

No.	Item	Description
1	Inlet port flange	ICF <sup>*1</sup> 253
2	Inlet port flange	VG <sup>*2</sup> 200
3	Height of the purge port	
4	Bending dimension of the STP connection cable	
5	Temperature sensor connector	Optional accessory
6	Screw hole of legs	M12 <sup>*2</sup> depth 20
7	Cooling water port	2-Rc <sup>*3</sup> 1/4
8	Outlet port flange	KF <sup>*2</sup> 40
9	STP connector	
10	Screw hole for legs	8-M12 <sup>*2</sup> depth 24
11	Purge port	KF <sup>*2</sup> 10
12	Viewed from arrow A	

<sup>\*1</sup> JVIS

<sup>\*2</sup> JIS

<sup>\*3</sup> ISO

(3 Pump external views)

**【Object pump type】**

- STP-A803C → STP-A803CV
- STP-A1303C → STP-A1303CV

As shown in external view below, TMS heater and TMS sensor are attached to STP pump in TMS specification (CV type).

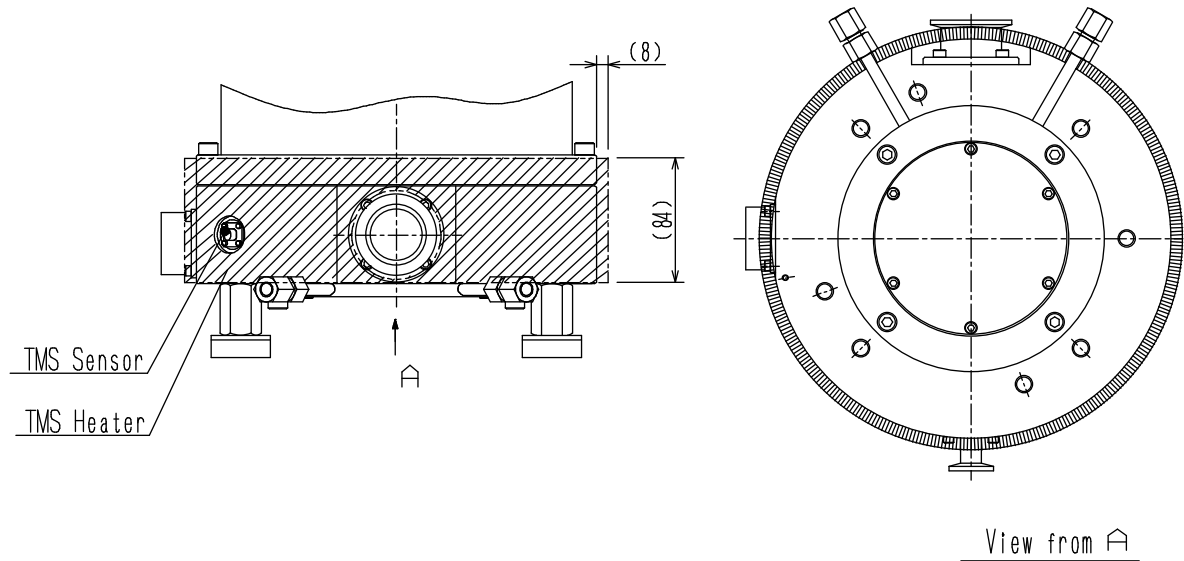

**STP-A803CV/STP-A1303CV**

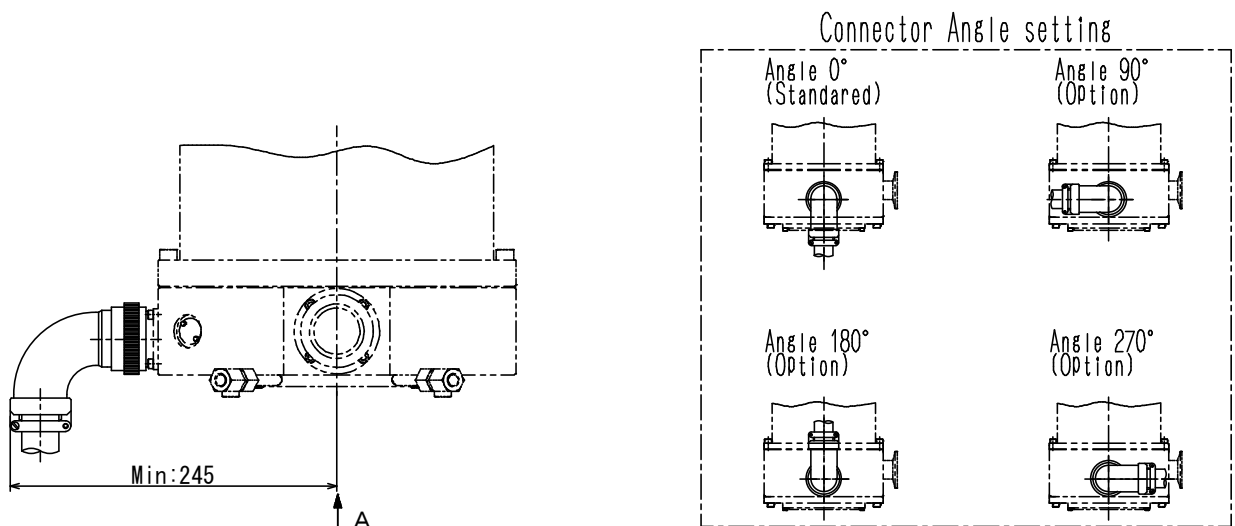

**STP-A803/STP-A1303 series L-type connector**



## 8 STP control unit detailed specification

### 8.1 I/O Remote

Specification for Remote input and output signal on Remote Connector X7<sup>\*1</sup>

Pin No	Description	Pin No	Description
1	COM. (IN)	20	
2		21	STOP IN
3	START IN	22	RESET IN
4	REM_IN_OPT1 <sup>*2</sup>	23	REM_IN_OPT2 <sup>*2</sup>
5	INHIBIT IN	24	WARNING OUT (N.O.)
6	WARNING OUT (COM)	25	WARNING OUT (N.C.)
7	L.VALVE OUT (N.O.) <sup>*2</sup>	26	L.VALVE OUT (N.O.) <sup>*2</sup>
8	REMOTE OUT (N.O.)	27	REMOTE OUT (N.O.)
9	POWER OUT (N.O.)	28	POWER OUT (N.O.)
10	ACCELERATION OUT (N.O.)	29	ACCELERATION OUT (N.O.)
11	NORMAL OUT (N.O.)	30	NORMAL OUT (COM.)
12	NORMAL OUT (N.C.)	31	
13	BRAKE OUT (N.O.)	32	BRAKE OUT (N.O.)
14	ALARM OUT (N.O.)	33	ALARM OUT (COM.)
15	ALARM OUT (N.C.)	34	
16	AT TEMP. OUT (N.O.) <sup>*3</sup>	35	AT TEMP. OUT (N.C.) <sup>*3</sup>
17	AT TEMP. OUT (COM.) <sup>*3</sup>	36	OPT.1 OUT (N.O.) <sup>*2</sup>
18	OPT.1 OUT (COM) <sup>*2</sup>	37	OPT.1 OUT (N.C.) <sup>*2</sup>
19			

IN: Input pin, OUT: Output pin. COM.: Common,  
N.O.<sup>\*4</sup>: Normal Open, N.C.<sup>\*5</sup>: Normal Close,  
Input signal specification: Operation by Close/Open between COM. (IN) and each Input pin.  
Output signal specification: Relay contact output.  
Contact point ratings is 125 Vac/0.5 A, 24 Vdc/1 A  
Connector type: D-sub 37 pin (Socket), The screw for the remote connector is M2.6.  
Connector for the remote cable needs to be provided by the customer.  
It is recommended to use a remote cable with shield type, and connect both terminals to ground.

<sup>\*1</sup>: Please refer to the Instruction Manual for the detail explanations.

<sup>\*2</sup>: This is not used in the standard specification pump.

<sup>\*3</sup>: This signal will be set when TMS detects the measured temperature is inside +/-10 °C from the setting temperature.

<sup>\*4</sup>: N.O; The contact will close when the STP pump status becomes the stated status.

<sup>\*5</sup>: N.C; The contact will open when the STP pump status becomes the stated status.

## 8.2 RS232/RS485

Specification of Serial port COM1 (X3A, X3B) for both RS232 and 485 \*1

	STP control unit side X3A	STP control unit side X3B	PC side connector (example of DOS/V compatible machine)	
	(D-sub 9 pin, Socket)	(D-sub 9 pin, Socket)	D-sub 9 pin	D-sub 25 pin
RS232	2 (TxD)	-	2 (TxD)	3 (TxD)
	3 (RxD)	-	3 (RxD)	2 (RxD)
	5 (GND)	-	5 (GND)	7 (GND)
RS485	7 (D-)	7 (D-)	-	-
	8 (D+)	8 (D+)	-	-
Not for use	1, 4, 6, 9	1, 2, 3, 4, 5, 6, 9	-	-

Screw size of the connector housing for X3A and X3B is M2.6.  
The connectors for the serial cables need to be provided by the customer.  
It is recommended to use a serial communication cable with shield type, and connect both terminals to ground. DO NOT connect anything to these unused pins.

## 9 Attachment component

Below parts are attached with the pump as standard.

Item	Q' ty	Note
Blank fange for parge port (KF10)	1	
Clamper for purge port (KF10)	1	
O-ring for the purge port (KF10)	1	
Leg	8	
Instruction Manual	1	

## 10 Accessory

There is no accessory available for STP-A803/STP-A1303.

---

# Turbo Molecular Pump

## STP-A803/A1303 series Selection Guide

---

### Pump Type

- STP-A803C
- STP-A1303C
- STP-A803CV
- STP-A1303CV

# STP-A803/A1303 series Selection Guide

Please complete a kit using the Product Structure and the Selection Flow Chart.

### <Product Structure>

	Item	Q'ty
(1)	STP pump	1
(2)	STP control unit	1
(3)	Power cable	1
(4)	STP connection cable	1
Parts (5) to (8) under this line are for STP-A803CV/A1303CV (with TMS) only		
(5)	TMS connection cable	1
(6)	TMS valve (with cable)	1
(7)	TMS heater (attached on the pump)	1
(8)	TMS sensor cable	1

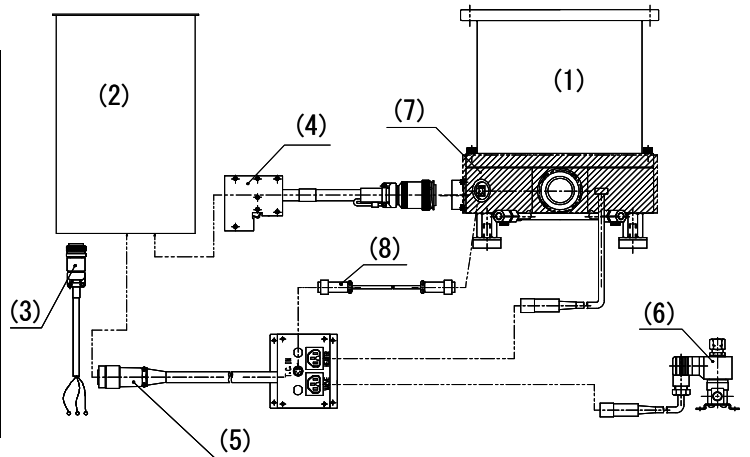

### < Selection Flow Chart >

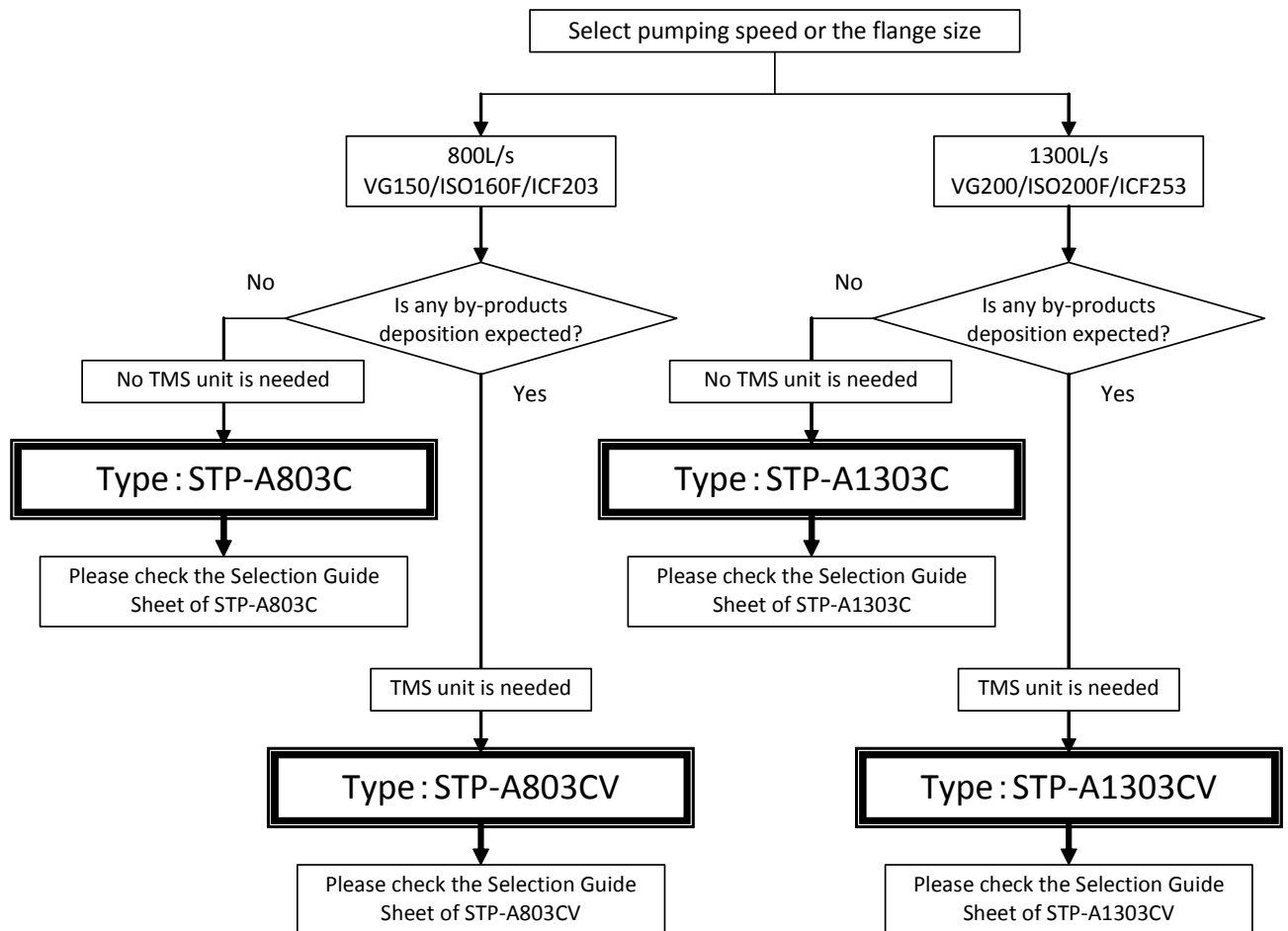

### STP-A803C Selection Guide Sheet

Please tick the boxes to order the components.

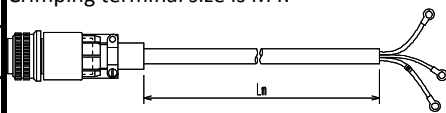
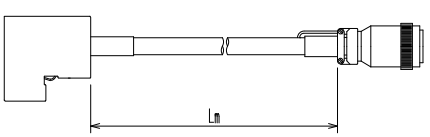
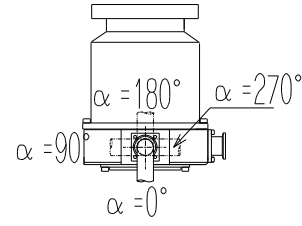
<input type="checkbox"/> Pump type: STP-A803C (without TMS unit)		Item	Part number	Select	Note
(1) STP pump	VG150	YT360Z000	<input type="checkbox"/>	Select flange size. Outlet port: KF40 Purge port: KF10 Water pipe fitting: Rc1/4(ISO standard)	
	ISO160F	YT360Z110	<input type="checkbox"/>		
	ICF203	YT360Z100	<input type="checkbox"/>		
(2) STP control unit	SCU-800	YT49Z2Z00	<input checked="" type="checkbox"/>	Input voltage: 200 Vac to 240 Vac	
(3) Power cable	Please select cable length.				
	5 m	PT49Y0A00	<input type="checkbox"/>	 Crimping terminal size is M4.	
	10 m	PT49Y0A01	<input type="checkbox"/>		
	15 m	PT49Y0A02	<input type="checkbox"/>		
	20 m	PT49Y0A03	<input type="checkbox"/>		
(4) STP connection cable	Please select connector type and cable length.				
Both side straight connector	5 m	B75130020	<input type="checkbox"/>		
	10 m	B75130060	<input type="checkbox"/>		
	15 m	B75130070	<input type="checkbox"/>		
	20 m	B75130190	<input type="checkbox"/>		
- Pump side L-type connector ( $\alpha=0^\circ$ ) - Controller side straight	5 m	PT46Y1B00	<input type="checkbox"/>	 Need to select angle for L-type connector	
	10 m	PT46Y1B01	<input type="checkbox"/>		
	15 m	PT46Y1B02	<input type="checkbox"/>		
	20 m	B71830060	<input type="checkbox"/>		
- Pump side L-type connector ( $\alpha=90^\circ$ ) - Controller side straight	5 m	PT46Y1B05	<input type="checkbox"/>		
	10 m	PT46Y1B06	<input type="checkbox"/>		
	15 m	PT46Y1B07	<input type="checkbox"/>		
	20 m	PT46Y1B28	<input type="checkbox"/>		
Instruction Manual			<input checked="" type="checkbox"/>	CD	

\* Maximum length of all cables is 30 meters.

### STP-A1303C Selection Guide Sheet

Please tick the boxes to order the components.

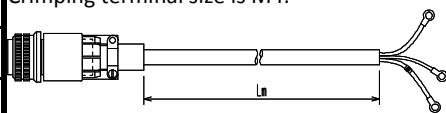
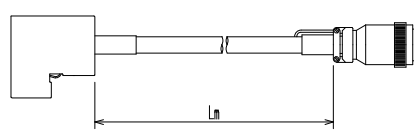
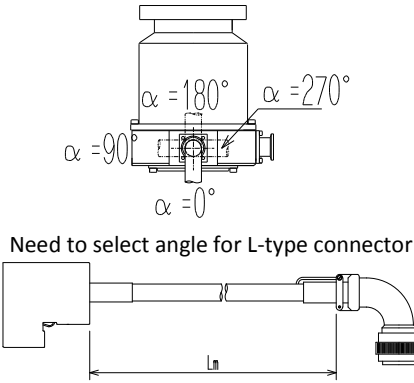

Pump type: STP-A1303C (without TMS unit)

Item		Part number	Select	Note
(1) STP pump	VG200	YT360Z010	<input type="checkbox"/>	Select flange size. Outlet port: KF40 Purge port: KF10 Water pipe fitting: Rc1/4(ISO standard)
	ISO200F	YT36B0120	<input type="checkbox"/>	
	ICF253	YT360Z130	<input type="checkbox"/>	
(2) STP control unit	SCU-800	YT49Z2Z00	<input checked="" type="checkbox"/>	Input voltage: 200 Vac to 240 Vac
(3) Power cable	Please select cable length.			Crimping terminal size is M4. 
	5 m	PT49Y0A00	<input type="checkbox"/>	
	10 m	PT49Y0A01	<input type="checkbox"/>	
	15 m	PT49Y0A02	<input type="checkbox"/>	
	20 m	PT49Y0A03	<input type="checkbox"/>	
(4) STP connection cable	Please select connector type and cable length.			  Need to select angle for L-type connector
Both side straight connector	5 m	B75130020	<input type="checkbox"/>	
	10 m	B75130060	<input type="checkbox"/>	
	15 m	B75130070	<input type="checkbox"/>	
	20 m	B75130190	<input type="checkbox"/>	
- Pump side L-type connector ( $\alpha=0^\circ$ ) - Controller side straight	5 m	PT46Y1B00	<input type="checkbox"/>	
	10 m	PT46Y1B01	<input type="checkbox"/>	
	15 m	PT46Y1B02	<input type="checkbox"/>	
	20 m	B71830060	<input type="checkbox"/>	
- Pump side L-type connector ( $\alpha=90^\circ$ ) - Controller side straight	5 m	PT46Y1B05	<input type="checkbox"/>	
	10 m	PT46Y1B06	<input type="checkbox"/>	
	15 m	PT46Y1B07	<input type="checkbox"/>	
	20 m	PT46Y1B28	<input type="checkbox"/>	
Instruction Manual			<input checked="" type="checkbox"/>	CD

\* Maximum length of all cables is 30 meters.

### STP-A803CV Selection Guide Sheet

Please tick the boxes to order the components.

Pump type: STP-A803CV (with TMS unit)

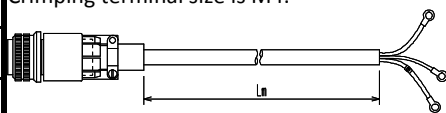
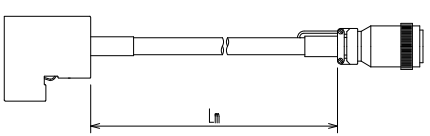
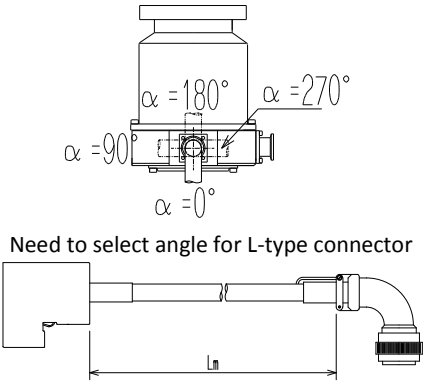
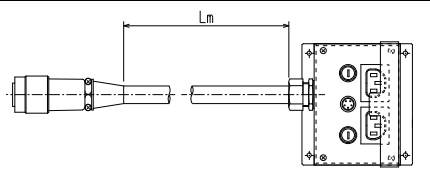
Item	Part number	Select	Note	
(1) STP pump with TMS Heater (7)	VG150	YT3626001	<input type="checkbox"/> Select flange size. Outlet port: KF40 Purge port: KF10 Water pipe fitting: Rc1/4(ISO standard)	
	ISO160F	YT3626000		
	ICF203	YT3626003		
(2) STP control unit	SCU-800	YT49Z2Z00	<input checked="" type="checkbox"/> Input voltage: 200 Vac to 240 Vac	
(3) Power cable	Please select cable length.		Crimping terminal size is M4. 	
	5 m	PT49Y0A00		<input type="checkbox"/>
	10 m	PT49Y0A01		<input type="checkbox"/>
	15 m	PT49Y0A02		<input type="checkbox"/>
	20 m	PT49Y0A03		<input type="checkbox"/>
(4) STP connection cable	Please select connector type and cable length.		  <p>Need to select angle for L-type connector</p>	
Both side straight connector	5 m	B75130020		<input type="checkbox"/>
	10 m	B75130060		<input type="checkbox"/>
	15 m	B75130070		<input type="checkbox"/>
	20 m	B75130190		<input type="checkbox"/>
- Pump side L-type connector ( $\alpha=0^\circ$ ) - Controller side straight	5 m	PT46Y1B00		<input type="checkbox"/>
	10 m	PT46Y1B01		<input type="checkbox"/>
	15 m	PT46Y1B02		<input type="checkbox"/>
	20 m	B71830060		<input type="checkbox"/>
- Pump side L-type connector ( $\alpha=90^\circ$ ) - Controller side straight	5 m	PT46Y1B05		<input type="checkbox"/>
	10 m	PT46Y1B06		<input type="checkbox"/>
	15 m	PT46Y1B07		<input type="checkbox"/>
	20 m	PT46Y1B28	<input type="checkbox"/>	
(5) TMS connection cable Kit	Please select cable length.			
Include TMS connection cable, TMS valve (6), and TMS sensor cable (8). TMS heater (7) is included in the Pump.	5 m	PT330V000		<input type="checkbox"/>
	10 m	PT330V001		<input type="checkbox"/>
	15 m	PT330V002		<input type="checkbox"/>
	20 m	PT330V003		<input type="checkbox"/>
Instruction Manual			<input checked="" type="checkbox"/> CD	

\* Maximum length of all cables is 30 meters.

### STP-A1303CV Selection Guide Sheet

Please tick the boxes to order the components.

Pump type: STP-A1303CV (with TMS unit)

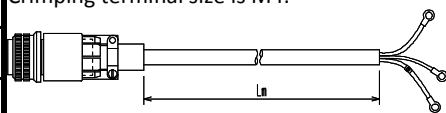
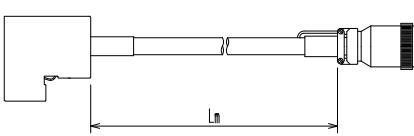
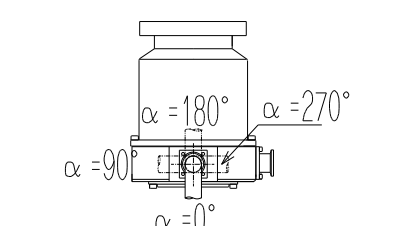
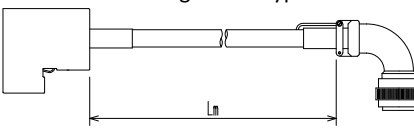
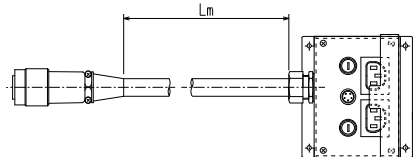
Item	Part number	Select	Note	
(1) STP pump with TMS Heater (7)	VG200	YT3626002	Select flange size. Outlet port: KF40 Purge port: KF10 Water pipe fitting: Rc1/4(ISO standard)	
	ISO200F	YT3626005		
	ICF253	YT3626004		
(2) STP control unit	SCU-800	YT49Z2Z00	<input checked="" type="checkbox"/> Input voltage: 200 Vac to 240 Vac	
(3) Power cable	Please select cable length.		Crimping terminal size is M4. 	
	5 m	PT49Y0A00		<input type="checkbox"/>
	10 m	PT49Y0A01		<input type="checkbox"/>
	15 m	PT49Y0A02		<input type="checkbox"/>
	20 m	PT49Y0A03		<input type="checkbox"/>
(4) STP connection cable	Please select connector type and cable length.		  Need to select angle for L-type connector 	
Both side straight connector	5 m	B75130020		<input type="checkbox"/>
	10 m	B75130060		<input type="checkbox"/>
	15 m	B75130070		<input type="checkbox"/>
	20 m	B75130190		<input type="checkbox"/>
- Pump side L-type connector ( $\alpha=0^\circ$ ) - Controller side straight	5 m	PT46Y1B00		<input type="checkbox"/>
	10 m	PT46Y1B01		<input type="checkbox"/>
	15 m	PT46Y1B02		<input type="checkbox"/>
	20 m	B71830060		<input type="checkbox"/>
- Pump side L-type connector ( $\alpha=90^\circ$ ) - Controller side straight	5 m	PT46Y1B05		<input type="checkbox"/>
	10 m	PT46Y1B06		<input type="checkbox"/>
	15 m	PT46Y1B07		<input type="checkbox"/>
	20 m	PT46Y1B28	<input type="checkbox"/>	
(5) TMS connection cable Kit Include TMS connection cable, TMS valve (6), and TMS sensor cable (8). TMS heater (7) is included in the Pump.	Please select cable length.			
	5 m	PT330V000		<input type="checkbox"/>
	10 m	PT330V001		<input type="checkbox"/>
	15 m	PT330V002		<input type="checkbox"/>
	20 m	PT330V003		<input type="checkbox"/>
Instruction Manual			<input checked="" type="checkbox"/> CD	

\* Maximum length of all cables is 30 meters.