

Instruction Manual

Wide Range Gauge

Description	Item Number
WRG-S-NW25	D14701000
WRG-SL-NW25	D14711000
WRG-D-NW25	D14702000
WRG-S-DN40CF	D14703000

Original Instructions



Declaration of Conformity

Edwards Ltd,
Innovation Drive,
Burgess Hill,
West Sussex,
RH15 9TW, UK

The following product

Wide Range Gauge

WRG-S-NW25	D14701000
WRG-SL-NW25	D14711000
WRG-D-NW25	D14702000
WRG-S-DN40CF	D14703000

Is in conformity with the relevant requirements of European CE legislation:

2014/30/EU	Electromagnetic compatibility (EMC) directive
2012/19/EU	Waste from electrical and electronic equipment (WEEE) directive
2011/65/EU	Restriction of certain hazardous substances (RoHS) directive

Based on the relevant requirements of harmonised standards:

EN 61010-1:2010	Safety requirements for electrical equipment for measurement, control and laboratory use. General requirements
EN 61326-2-3:2013 (Class B Emissions, Industrial Immunity)	Electrical equipment for measurement, control and laboratory use. EMC requirements. Particular requirements. Test configuration, operational conditions and performance criteria for transducers with integrated or remote signal conditioning

The product also complies with the following:

CSA-C22.2 No.61010-1-12	Safety requirements for electrical equipment for measurement, control and laboratory use – Part 1: General requirements
UL61010-1 3 rd Edition	Safety requirements for electrical equipment for measurement, control and laboratory use – Part 1: General requirements

This covers all product serial numbers from the date of this declaration onwards.



Larry Marini, Senior Technical Manager

17.01.2019, Eastbourne

Date and Place

Material Declaration

In accordance with the requirements of the Chinese regulatory requirement on the Management Methods for the Restriction of the Use of Hazardous Substances in Electrical and Electronic Products Order No. 32 (also known as 'China RoHS2') and SJ/T 11364 Marking for the Restricted Use of Hazardous Substances in Electronic and Electrical Products:

Product	Product Label	Meaning
D14701000 WRG-S-NW25 D14711000 WRG-SL-NW25 D14702000 WRG-D-NW25 D14703000 WRG-S-DN40CF		This product contains hazardous substances in at least one of the homogeneous materials used which are above the limit requirement in GB/T 26572 as detailed in the declaration table below. These parts can safely be used for the environmental protection use period as indicated.

材料成分声明 Materials Content Declaration

部件名称 Part name	有害物质 Hazardous Substances					
	铅 Lead (Pb)	汞 Mercury (Hg)	镉 Cadmium (Cd)	六价铬 Hexavalent Chromium (Cr VI)	多溴联苯 Polybrominated biphenyls (PBB)	多溴二苯醚 Polybrominated diphenyl ethers (PBDE)
印刷电路组件 (PCA) Printed Circuit Assembly (PCA)	X	O	X	O	O	O
电缆/电线/连接器 Cable/wire/connector	X	O	O	O	O	O
机械部件 Mechanical Components	X	O	O	O	O	O

O: 表示该有害物质在该部件的所有均质材料中的含量低于 GB/T 26572 标准规定的限量要求。
O: Indicates that the hazardous substance contained in all of the homogeneous materials for this part is below the limit requirement in GB/T 26572.
X: 表示该有害物质在该部件的至少一种均质材料中的含量超出 GB/T26572 标准规定的限量要求。
X: Indicates that the hazardous substance contained in at least one of the homogeneous materials used for this part is above the limit requirement of GB/T26572.

NOTE: These products are EU RoHS compliant, the following Exemptions apply:

- 6(b) **Lead** as an alloying element in aluminium containing up to 0.4% by weight
- 6(c) Copper alloy containing up to 4% **lead** by weight
- 7(a) **Lead** in in high melting temperature type solder (i.e. lead based alloys containing 85% by or more)
- 7(b) **Lead** in solders for servers, storage and storage array systems, network infrastructure equipment for switching, signalling, transmission, and network management for telecommunications
- 7(c) I **Lead** in electrical and electronic components containing **lead** in a glass or ceramic other than dielectric ceramic in capacitors, e.g. piezoelectronic devices, or in a glass or ceramic matrix compound
- 7(c) II **Lead** in dielectric ceramic in capacitors for a rated voltage of 125 V AC or 250 V DC or higher
- 8(b) **Cadmium** and its compounds in electrical contacts
- 15 **Lead** in solders to complete a viable electrical connection between semiconductor die and carrier within integrated circuit flip chip packages
- 34 **Lead** in cermet-based trimmer potentiometer elements

Page left blank for D of C to be inserted
This page has been intentionally left blank.

Contents

Section	Page
1	Introduction 1
1.1	Scope and definitions 1
1.2	Description 1
1.3	Gas dependency 2
2	Technical data 5
2.1	Mechanical data 5
2.2	Performance, operating and storage conditions 5
2.3	Electrical data 5
2.4	Materials exposed to vacuum 6
3	Installation 11
3.1	Unpack and inspect 11
3.2	Fit the WRG to the vacuum system 11
3.3	Electrical connections 11
3.3.1	Connect to Edwards controllers or AGD display 11
3.3.2	Connect to customer supply and control equipment 12
4	Operation 13
4.1	Safety 13
4.2	Pressure measurement 14
4.3	Atmosphere adjustment 14
4.4	Vacuum adjustment 15
4.5	Setpoint 15
4.6	Error monitoring 16
5	Maintenance 17
5.1	Introduction 17
5.2	Replace the body tube 17
5.3	Replace the electrode and pirani assemblies 18
5.4	Replace the electronics and magnet housing 19
5.5	Clean the internal components 19
6	Storage and disposal 21
6.1	Storage 21
6.2	Disposal 21
7	Service, spares and accessories 23
7.1	Introduction 23
7.2	Service 23
7.2.1	Return the equipment or components for service 23
7.3	Spares 24
7.4	Accessories 24

Illustrations

Figure	Page
1 General view of the WRG-S and -SL	2
2 General view of the WRG-D	3
3 Dimensions (mm) of the WRG-S-NW25 and WRG-SL-NW25	7
4 Dimensions (mm) of the WRG-D-NW25	8
5 Dimensions (mm) of the WRG-S-DN40CF	9
6 Schematic diagram of typical electrical connections for the WRG	12
7 Pressure-voltage characteristic of the WRG	14
8 Refitting the body tube assembly	18
9 Exploded view of the body tube assembly	20

Tables

Table	Page
1 Pin identification	12

Trademark credits

Edwards and the Edwards logo are trademarks of Edwards Limited, Innovation Drive, Burgess Hill, West Sussex, RH15 9TW, UK.

Scotchbrite™ is a trademark of 3M Global Trading, Inc.

1 Introduction

1.1 Scope and definitions

This manual provides installation, operation and maintenance instructions for the Edwards Wide Range Gauge (WRG). The WRG must be used as specified in this manual. Read this manual before installing and operating the WRG.

Important safety information is highlighted as WARNING and CAUTION instructions; these instructions must be obeyed. The use of WARNINGS and CAUTIONS is defined below.



WARNING

Warnings are given where failure to observe the instruction could result in injury or death to people.

CAUTION

Cautions are given where failure to observe the instruction could result in damage to the equipment, associated equipment or process.

The units used throughout the manual conform to the SI international system of units of measurement.

The following symbol is on the Wide Range Gauge:



Edwards offer European customers a recycling service.

1.2 Description

The Wide Range Gauge, shown in [Figure 1](#), is a combined inverted magnetron and pirani gauge in a single compact unit.

The WRG incorporates a unique striking mechanism consisting of a small incandescent filament mounted inside the magnetron tube. This filament is automatically ignited, providing enough emission electrons to initiate the discharge.

The WRG incorporates an intelligent, microprocessor-based control system that is used to control various features, including:

- Automatic control of the magnetron HT voltage during the ignition of the gauge.
- Reduction of the HT voltage after ignition to enhance the life time of the gauge.
- Automatic adjustment of the pirani vacuum reading.
- Provision of an error monitoring feature which will help identify the exact cause of failure.
- Simple adjustment of the setpoint trip level.

Three versions of the WRG are available: the 'S', 'SL' and the 'D' gauges. The 'S' and 'SL' versions have an FCC68 connector socket while the 'D' version has a 9-way, D-type socket. The 'SL' gauges have a very low external magnetic field and are suitable for use with sensitive analytical instruments. The 'S' version is available with either a NW25 or DN40CF flange.

The WRG is compatible with the range of Active Gauge Controllers (AGC) and with the appropriate versions of the Active Gauge Display (AGD). Alternatively, an independent power supply can be used for the WRG and the output signal can be read with a voltmeter or an analogue-to-digital converter.

The WRG has a setpoint facility. The setpoint signal is an open-collector transistor output that is on when the pressure measured by the gauge is below a preset pressure. The pressure at which the setpoint output is activated can be adjusted (refer to Section 4.5).

Note: If an Active Gauge Controller or Active Gauge Display is used, the WRG setpoint output signal is not used.

1.3 Gas dependency

In the pirani measurement range, the rate of heat transfer through a gas is dependent upon both the pressure and the Relative Molecular Mass (RMM) of the gas. Similarly, in the inverted magnetron measurement range, the ionisation of the gas in the vacuum system is dependent on both the pressure and the physical properties of the gas, therefore the output signal of the WRG is gas dependent.

The output signal voltage to pressure conversion equations in Section 4.2 apply for nitrogen and dry air.

Figure 1 - General view of the WRG-S and -SL

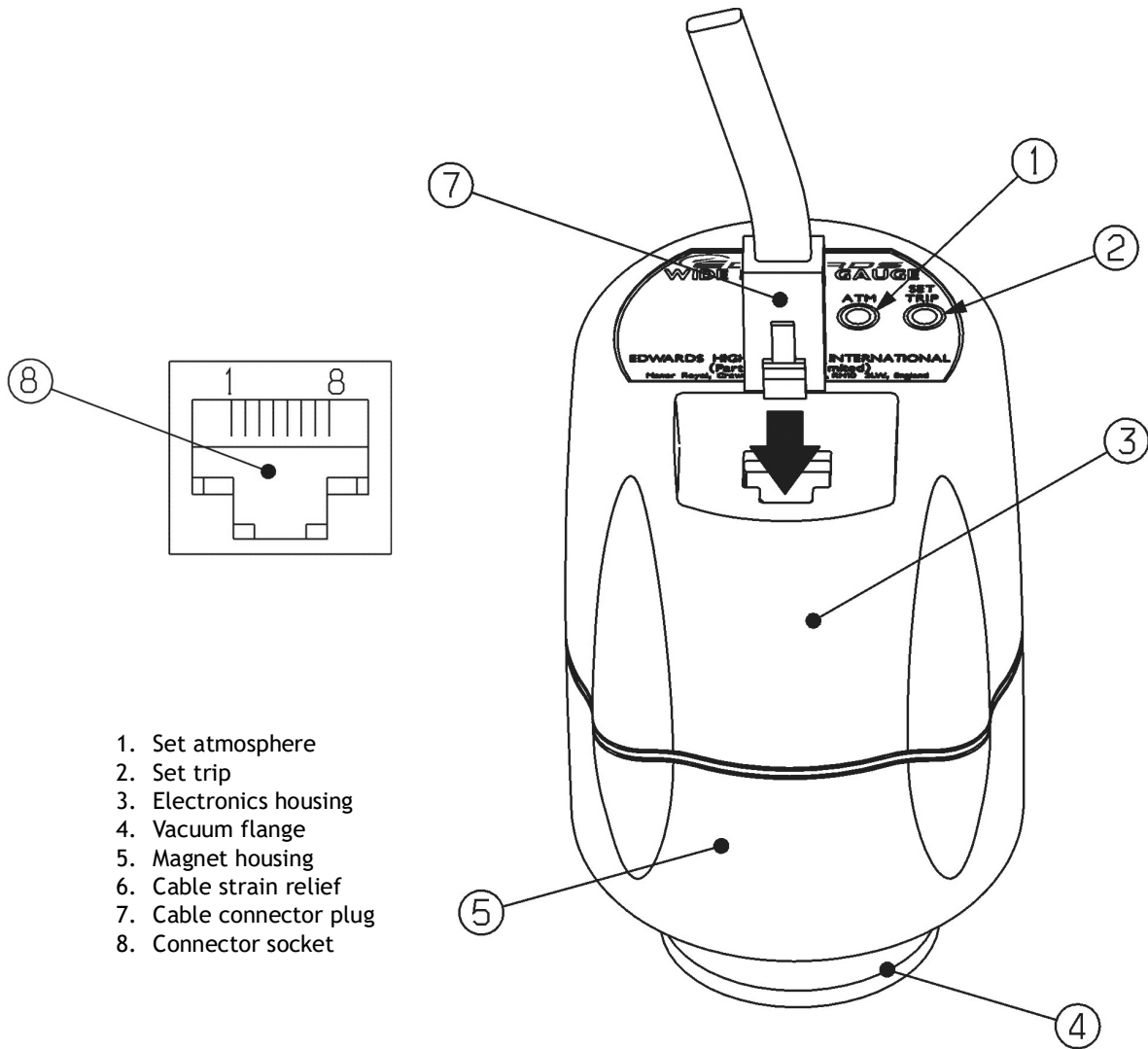

- 1. Set atmosphere
- 2. Set trip
- 3. Electronics housing
- 4. Vacuum flange
- 5. Magnet housing
- 6. Cable strain relief
- 7. Cable connector plug
- 8. Connector socket

DCS/7823/001

Figure 2 - General view of the WRG-D

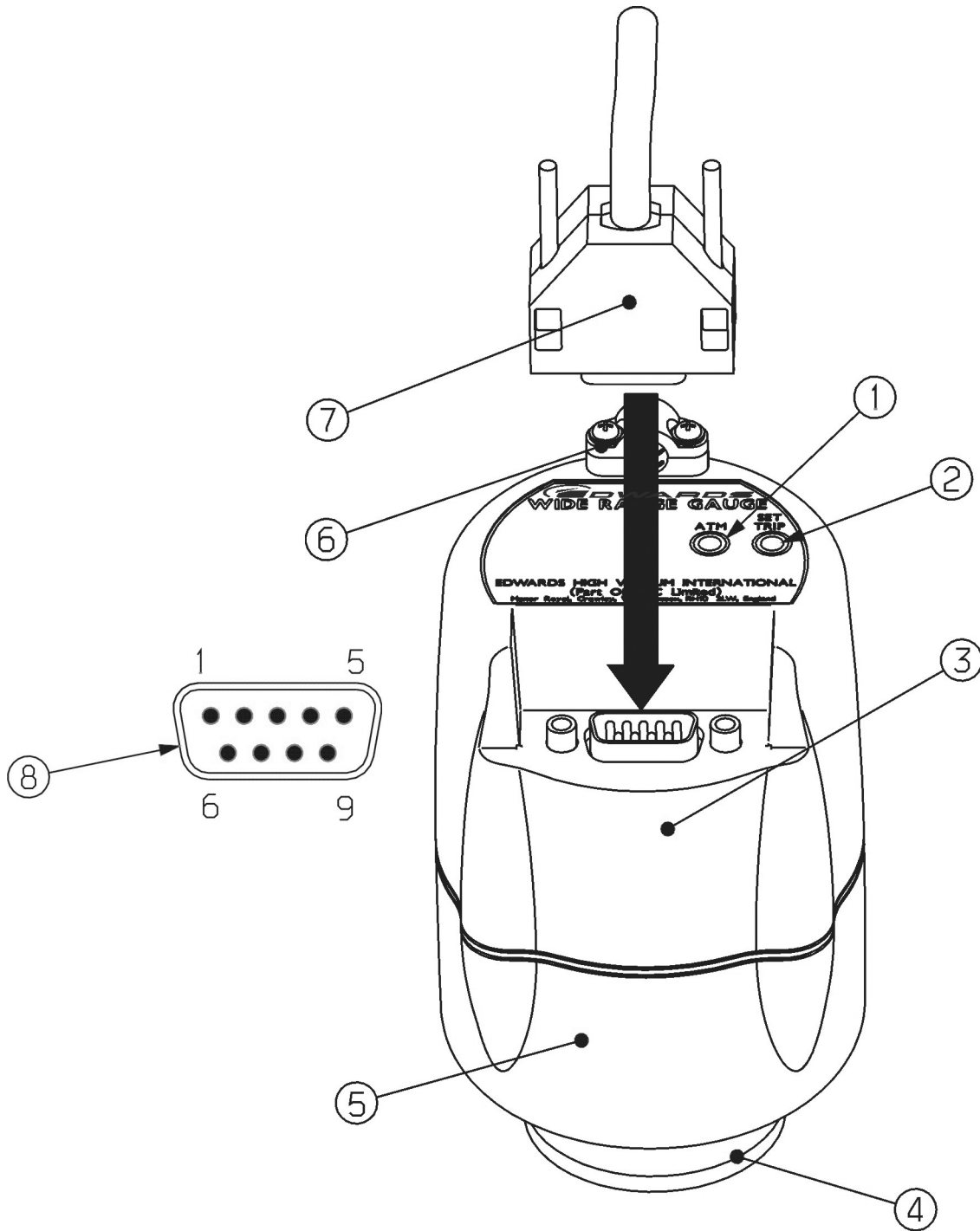

DCS/7823/002

- | | |
|------------------------|-------------------------|
| 1. Set atmosphere | 5. Magnet housing |
| 2. Set trip | 6. Cable strain relief |
| 3. Electronics housing | 7. Cable connector plug |
| 4. Vacuum flange | 8. Connector socket |

This page has been intentionally left blank.

2 Technical data

2.1 Mechanical data

Dimensions	See Figures 3, 4 and 5
Mass	
WRG-S-NW25	750 g
WRG-D-NW25	750 g
WRG-SL-NW25	800 g
WRG-S-DN40CF	1000 g
Volume of gauge tube	26 cm ³
Enclosure rating	
WRG-S-NW25	IP40
WRG-SL-NW25	IP40
WRG-S-DN40CF	IP40
WRG-D-NW25	IP44 (provided that the gauge is mounted vertically with the vacuum flange at the bottom)

2.2 Performance, operating and storage conditions

Ambient temperature	
Operation	5 to 60 °C
Storage	0 to 70 °C
Ambient humidity (operation)	max 90% RH (non-condensing) up to 31 °C max 70% RH (non-condensing) above 31 °C
Maximum internal pressure	6 bar absolute (5 bar gauge)
Maximum operating altitude	3000 m (indoor use only)
Pressure measurement range	100 to 10 ⁻⁹ mbar (indicates pressures up to 1000 mbar at reduced accuracy)
Pollution degree	2

2.3 Electrical data

Electrical supply	
Type	NEC Class 2 or Limited Power or Limited Energy
Voltage	+14.5 to +36 V d.c.
Max voltage ripple	1 V peak to peak
Max source resistance	50 Ω
Maximum power consumption	2 W
Electrical connector	
WRG-S-NW25	FCC68/RJ45 type, 8-way
WRG-SL-NW25	FCC68/RJ45 type, 8-way
WRG-S-DN40CF	FCC68/RJ45 type, 8-way
WRG-D-NW25	9 way D-type male

Pressure output signal	
Range	2 - 10 V d.c.
Error range	< 1.5 V d.c. or > 10.15 V d.c.
Impedance	0.1 Ω
Min load impedance	10 k Ω
Max current source	1 mA
Set-point output external load rating	40 V d.c., 100 mA maximum
Set-point trip level	
Range	1.8 to 10.2 V
Hysteresis	330 mV
Back EMF suppression diode *	
Min. surge rating	1 A
Min. reverse voltage rating	100 V
Atmosphere calibration input	
Control	Active low
Active level	< 1.5 V
Control impedance	100 k Ω pull-up to positive supply
Gauge identification resistance	75 k Ω \pm 2%

* Required when using an external d.c. relay connected to the setpoint output.

2.4 Materials exposed to vacuum

- Stainless steel (AISI 304, 316, 321, 347)
- Fluoroelastomer
- Soda lime glass
- Tungsten
- Trace of Nickel and Nickel iron

Figure 3 - Dimensions (mm) of the WRG-S-NW25 and WRG-SL-NW25

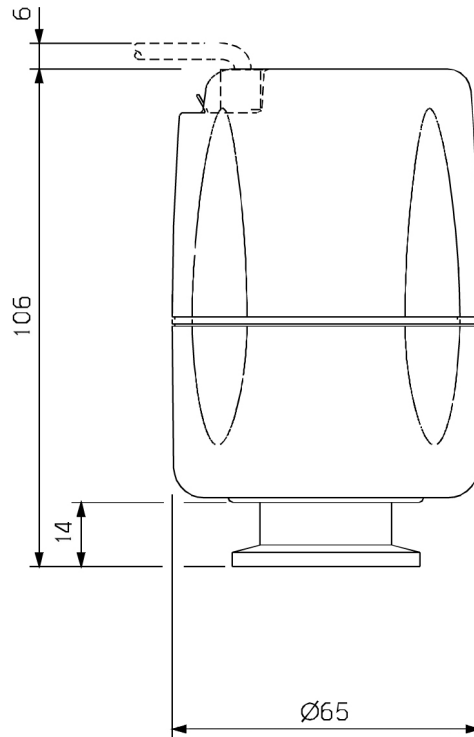

Figure 4 - Dimensions (mm) of the WRG-D-NW25

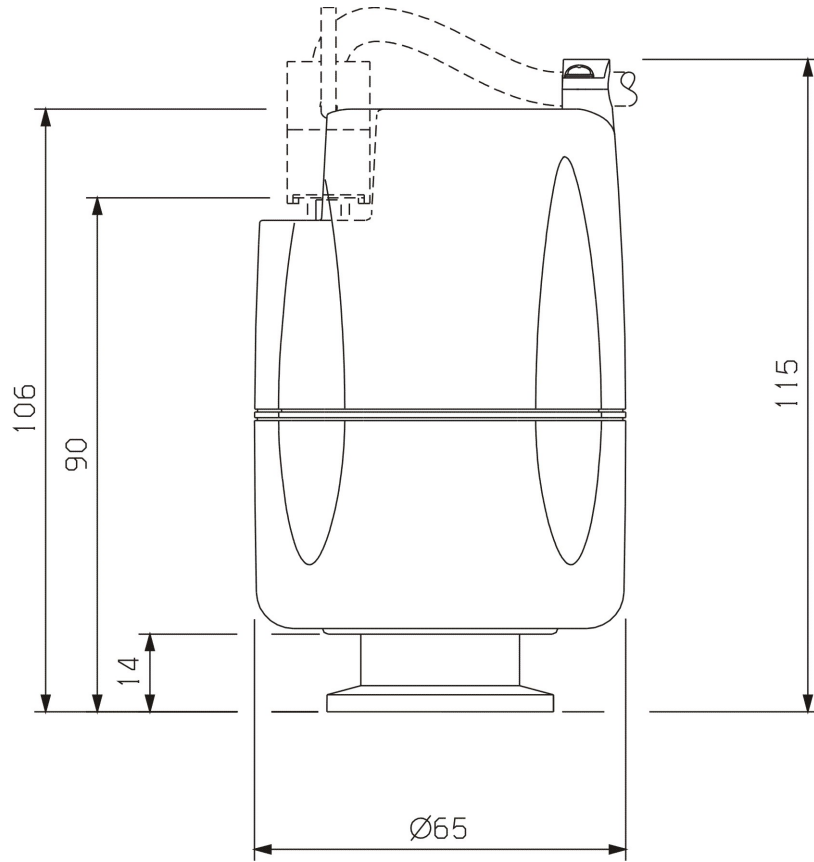
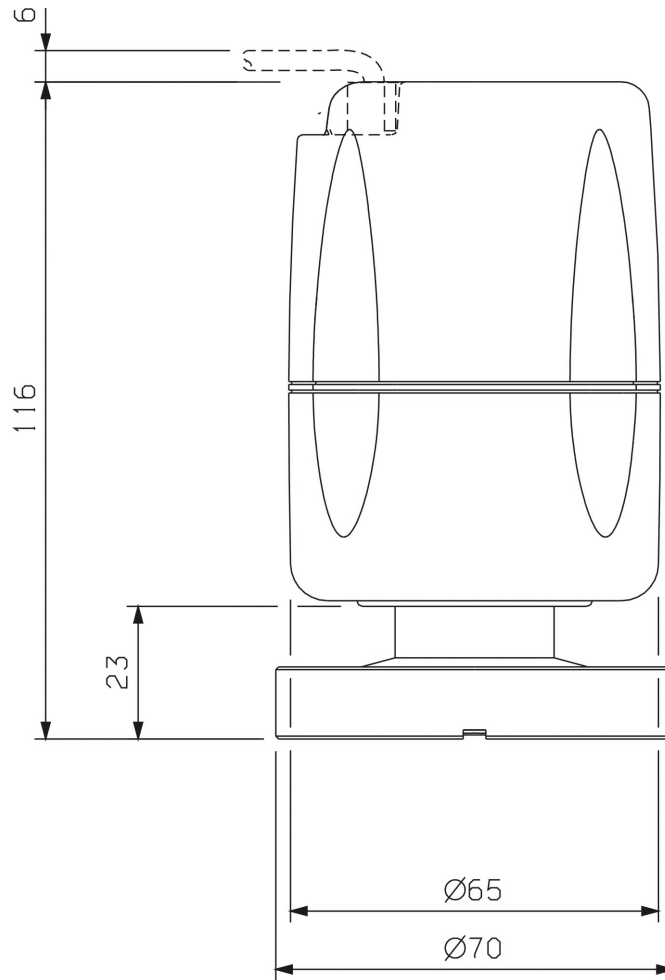

Figure 5 - Dimensions (mm) of the WRG-S-DN40CF



This page has been intentionally left blank.

3 Installation

3.1 Unpack and inspect



WARNING

The WRG incorporates magnets. Keep away from heart pacemakers, computers, credit cards and any other magnetically sensitive devices.



WARNING

Magnetic Field may interfere with pacemakers. Maintain a distance of minimum 10 cm between the magnet and the heart pacemaker. You can also use anti-magnetic shield to prevent the influence of strong magnetic field.



Remove all packing materials and protective covers and check the WRG.

If the WRG is damaged, notify the supplier and the carrier in writing within three days. State the Item Number of the WRG together with the order number and the supplier's invoice number. Retain all packing materials for inspection. Do not use the WRG if it is damaged.

If the WRG is not to be used immediately, replace the protective covers. Store the WRG in suitable conditions as described in [Section 6](#).

3.2 Fit the WRG to the vacuum system

The WRG can be mounted in any orientation. To avoid the buildup of debris or condensable material in the body tube of the WRG (which might cause pressure measurement errors), Edwards recommend installing the WRG vertically, as shown in [Figures 3, 4 and 5](#).

Use an O-ring / centring ring or Co-seal and clamp to connect the NW25 flange of the WRG to a similar flange on the vacuum system.

Use a copper gasket and screws to connect the DN40CF flange of the WRG-S-DN40CF to a similar flange on the vacuum system.

3.3 Electrical connections



WARNING

If the WRG malfunctions, the WRG pressure output may be incorrect. If such a failure could cause injury to people or damage equipment, install a suitable control system to indicate the failure and, if necessary, to close down the process system.

When using a cable longer than 30 m, full compliance with European Standards requires an in-line surge suppressor. (Refer to [Section 7.4](#)).

3.3.1 Connect to Edwards controllers or AGD display

Connect the WRG to the controller or display with a cable that is terminated in suitable connectors. Suitable cables are available upon request. (Refer to [Section 7.4](#)).

3.3.2 Connect to customer supply and control equipment

Note: Do not connect the electrical supply common (pin 2) to the signal common (pin 5) as the WRG pressure output signal may be inaccurate.

A schematic diagram of the recommended electrical connections to the WRG is shown in Figure 6.

The pins of the FCC68 and D-type sockets on the WRG electrical connection are used as shown in Table 1.

Table 1 - Pin identification

Pin Number	Connection
1	Supply positive
2	Supply common
3	Signal output
4	ID resistor
5	Signal common
6	Setpoint output
7	Atmosphere calibration
8	Not connected
9	Not connected (D-type connector only)

Connections to pins 4, 6 and 7 are optional.

Make the connection to pin 6 if connecting the setpoint output signal to a d.c. relay. A suppression diode must be connected between pin 1 and 6 to protect the WRG from transient voltage generated when the d.c. relay is switched off.

Measure between pins 4 and 5 to determine the value of the ID resistor.

Connect a switch between pins 2 and 7 to enable calibration of the gauge at atmosphere and vacuum. (Refer to Sections 4.3 and 4.4).

Figure 6 - Schematic diagram of typical electrical connections for the WRG

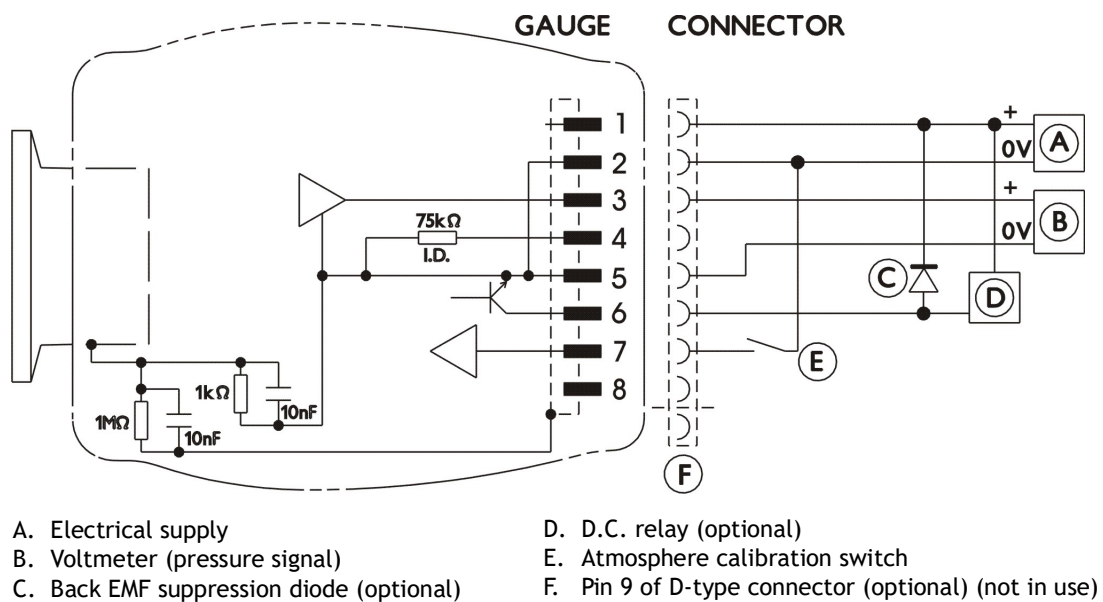

4 Operation

4.1 Safety



WARNING

Do not use the WRG to measure the pressure of explosive or flammable gases or mixtures.



WARNING

Never operate the WRG when it is disconnected from the vacuum system or when there are explosive or flammable gases in the surrounding atmosphere or the vacuum system. High voltages (up to 3 kV) are generated inside the body tube of the WRG; these could cause injury to people or could be a source of ignition.



WARNING

Do not disconnect the electronics and magnet housing from the body tube when the body tube is connected to the vacuum system. If there is a plasma discharge in the vacuum system near the body tube, the body tube can become electrically charged.



WARNING

When the pressure of gases of high molecular weight are measured, the pressure indicated can be below the true pressure. Ensure that the WRG is not over-pressurised when using heavy gases.



WARNING

Use the gauge only for its intended purpose as described in this instruction manual.

CAUTION

The WRG has a magnet that may affect devices that are sensitive to high magnetic fields. The effect is reduced on the -SL version.



WARNING

The WRG incorporates magnets. Keep away from heart pacemakers, computers, credit cards and any other magnetically sensitive devices.

4.2 Pressure measurement

If the WRG is connected to an Edwards AGC controller or AGD display, the pressure measured by the WRG is shown on the display.

If the signal output of the WRG is connected to a voltmeter, convert the measured voltage to the corresponding pressure value using the following equation:

$$\begin{aligned}
 P &= 10^{(1.5 V - 12)} \text{ mbar} \\
 &= 10^{(1.5 V - 10)} \text{ Pascal} \\
 &= 10^{(1.5 V - 12.125)} \text{ torr}
 \end{aligned}$$

where V is the measured voltage. For example, if the measured voltage V = 4, then pressure P = 10⁻⁶ mbar. Refer also to Figure 7.

4.3 Atmosphere adjustment

Use the "ATM" switch (Figures 1 and 2, item 1) or pin 7 and 2 to set the reading at atmosphere.

1. Switch on the power supply to the WRG and allow it to operate at atmospheric pressure for at least 10 minutes.
2. With the vacuum system at atmospheric pressure, press the "ATM" switch with an appropriate tool. The output of the gauge will be automatically adjusted to read atmosphere.

Figure 7 - Pressure-voltage characteristic of the WRG

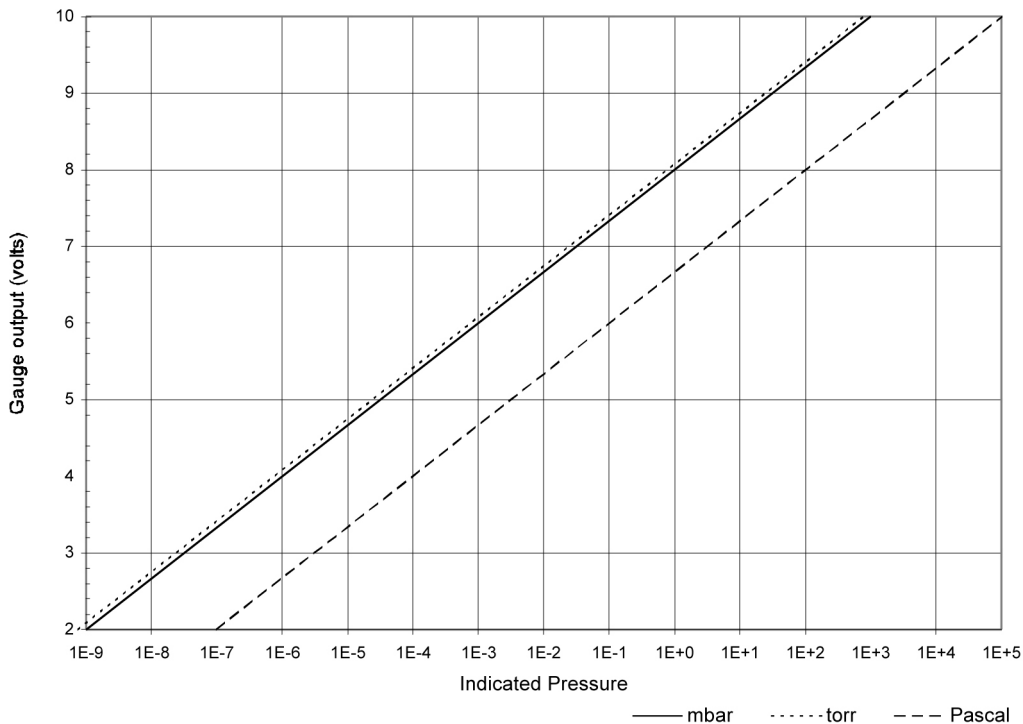

4.4 Vacuum adjustment

The WRG will perform the pirani sensor vacuum setting automatically every time the WRG is pumped down to a pressure lower than 10^{-4} mbar. Manual adjustment of the vacuum reading is recommended when replacing the pirani tube or after a long period of storage.

If the gauge fails to indicate pressure of $< 10^{-3}$ mbar, then a manual vacuum setting is required. To perform this operation, do the following.

1. Reduce the system pressure to 10^{-5} mbar or below and wait for 1 minute.
2. Press and release the “ATM” switch and wait for approximately 30 seconds until the adjustment is completed.

If an operator has tried to set the atmosphere or vacuum reading while the actual pressure is between 10^{-2} and 10^2 mbar, an error voltage of 1 V will be displayed indicating a pirani failure. (Refer to [Section 4.6.](#))

4.5 Setpoint

Note: *The setpoint is not used if the WRG is connected to an Edwards Active Gauge Controller or Active Gauge Display.*

To read the voltage at which the setpoint output signal is activated, press the set trip switch ([Figures 1 and 2](#), item 2) with an appropriate tool. The output of the gauge will indicate the set trip level for 3 seconds after which the output will read the normal voltage output.

To adjust the voltage at which the setpoint output signal is activated, press the set trip switch and hold it down for more than 3 seconds. The setpoint voltage will start scrolling upwards. Remove pressure from the switch as soon as the required trip voltage has been reached. To make a finer adjustment, remove pressure from the set trip switch and immediately depress the switch as many times as required. Each depression will increase the set trip voltage by about 10 mV. Refer to [Section 4.2](#) to determine the operating voltage that corresponds to a given pressure.

The WRG has an error monitoring facility that ensures the setpoint output signal is off:

- when the gauge is switched off
- for 2 seconds immediately after the WRG is switched on
- when the pressure output signal is out of range
- when an error voltage is detected. (Refer to [Section 4.6.](#))

If required, the setpoint operating voltage can be adjusted to < 1.9 V. This ensures that the setpoint output is permanently off.

If required, the setpoint output signal can be used to indicate when the gauge is operating correctly. Adjust the setpoint operating voltage to > 10.15 V. The setpoint output will then be on if the gauge is operating normally, and off if an error condition is detected.

Note: *If the setpoint operating voltage is adjusted to > 9.7 V, the hysteresis voltage will be > 10 V and the setpoint output signal may not switch off when the pressure rises. If so, the setpoint output signal will switch off only when the gauge is switched off.*

4.6 Error monitoring

The gauge is able to perform some internal error monitoring functions, and respond in a defined manner, as summarised below. These operate in conjunction with the user controls to define the gauge operation. The responses are prioritised in the order shown.

The error condition is reset (cleared) when the gauge is disabled or power is removed.

Error indications:	Output Voltage	Edwards Controllers Output
Pirani failure	1 V	ERR A
Inverted magnetron contaminated or short circuited	1.1 V	ERR B
Striker filament broken	1.2 V	ERR C
Inverted magnetron not struck	1.3 V	ERR D

The error condition 'striker filament broken' will occur only if the inverted magnetron fails to strike.

The setpoint will be disabled as soon as one of the above errors is detected.

5 Maintenance

5.1 Introduction



WARNING

Do not disconnect the electronics and magnet housing from the body tube when the body tube is connected to the vacuum system. If there is a plasma discharge in the vacuum system near the body tube, the pins of the anode assembly can become electrically charged.



WARNING

Disconnect the cable from the WRG before removing the WRG from the vacuum system. High voltages are generated inside the WRG.

The internal components of the WRG are shown in [Figure 9](#). The WRG is designed so that the components can be cleaned or replaced using the spares listed in [Section 7.3](#). Refer to the following sections for details of maintenance procedures that should be performed when necessary.

5.2 Replace the body tube

Refer to [Figure 8](#) and use the following procedures to replace the body tube.

To remove the body tube assembly:

1. Switch off the WRG electrical supply and ensure that the vacuum system is at atmospheric pressure.
2. Disconnect the cable connector plug ([Figures 1 and 2](#), item 7) and remove the WRG from the vacuum system.
3. Hold the magnet housing firmly and pull the body tube assembly to remove.

To refit the body tube assembly:

1. Insert the body tube assembly into the magnet housing and then rotate it while maintaining gentle pressure until the tube assembly locates. Push fully home until the locking spring snaps into position.
2. Refit the gauge to the vacuum system as described in [Section 3.2](#) and reconnect the electrical supply.

Figure 8 - Refitting the body tube assembly

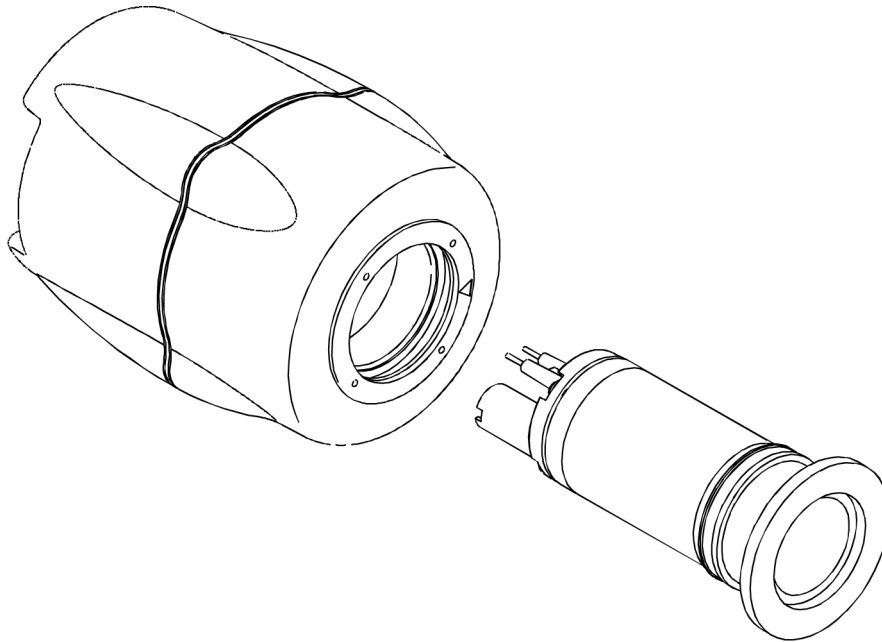

5.3 Replace the electrode and pirani assemblies

Refer to [Figure 9](#) and the following procedure.

1. Remove the WRG from the vacuum system and the body tube assembly from the WRG as described in [Section 5.2](#).
2. Use a suitable screwdriver to unscrew the four screws (1) on the top of the body tube and remove the pirani tube housing (2), pirani tube (4), viton gasket (5), anode assembly (6) and the viton O-ring (7) from the body tube (9).
3. Use circlip pliers to remove the circlip (12) from the vacuum flange end of the body tube (9), then remove the cathode tube (11) and the cathode plate (10).
4. Fit the new cathode plate (10) and cathode tube (11) into the body tube (9) and secure with the circlip (12).
5. Fit the new O-ring (7) and anode assembly (6) onto the body tube (9). Ensure that the orientation of the anode assembly is correct. Take care not to damage the striker filament (13).
6. Fit the pirani tube (4) inside the plastic pirani housing (2). Place the gasket (5) onto the pirani housing (2) and press with your thumb to locate it in the pirani housing (2).
7. Place the combination of the pirani housing (2), pirani tube (4) and the gasket (5) onto the anode assembly. Ensure that the three pins are located correctly.
8. Gently rotate the anode assembly together with the pirani assembly until the arrow (3) on the plastic pirani housing is aligned with the groove (8) in the body tube. Take care not to damage the striker filament (13).
9. Refit the four M2 screws (1) with their washers into the four holes in the plastic pirani housing (2) and tighten evenly to a torque of 0.2 N.m.
10. Refit the body tube to the magnet housing as described in [Section 5.2](#).

5.4 Replace the electronics and magnet housing

The magnet housing and end-cap contain the WRG control electronics. Replace the complete unit as described below.

1. Remove the WRG from the vacuum system and the body tube assembly as described in [Section 5.2](#).
2. Dispose of the old electronics and magnet housing. (Refer to [Section 6.2](#).)
3. Fit the body tube to the new electronics and magnet housing as described in [Section 5.2](#).
4. Refit the WRG to the vacuum system as described in [Section 3.2](#).

5.5 Clean the internal components

Refer to [Figure 9](#) in the following procedure.

1. Remove the internal components from the magnet housing as described in [Section 5.3](#).
2. Clean the pirani tube (4) in alcohol for about 5 minutes (using an ultrasonic tank if available). Place the pirani tube (4) with the opening end facing downward on a piece of clean tissue and leave it to dry.
3. Use an abrasive material (e. g. Scotchbrite™) to clean the anode assembly (6). Extra care is required when cleaning the area around the striker filament (13).
4. Clean the anode assembly (6) in alcohol for about 5 minutes (using an ultrasonic tank if available). Place the anode assembly (6) on a piece of clean tissue and leave it to dry.
5. Degrease the cathode plate (10), cathode tube (11) and body tube (9) in a suitable degreasing agent. Thoroughly soak them in a suitable laboratory detergent. Rinse in clean water to remove the detergent and then in methanol to remove all of the water, then thoroughly dry the components.
6. Refit the components in the electronics and magnet housing as described in [Section 5.2](#).

Figure 9 - Exploded view of the body tube assembly

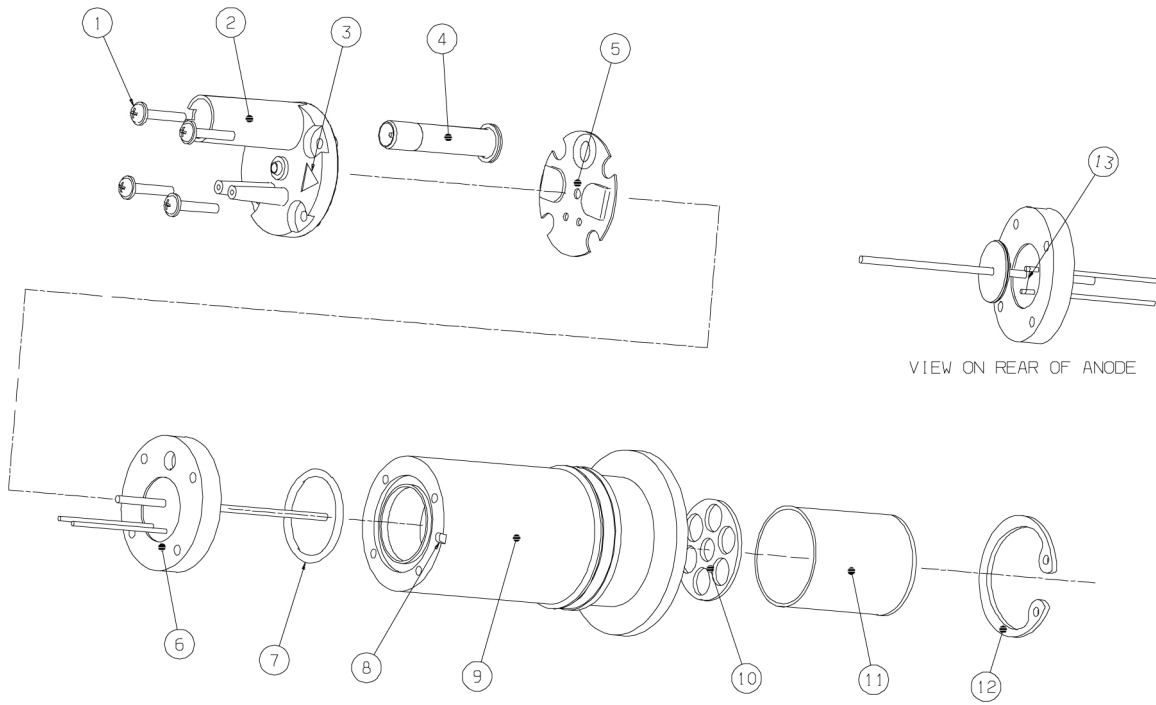

- | | |
|--------------------------|---------------------|
| 1. M2 screws and washers | 8. Alignment groove |
| 2. Pirani housing | 9. Body tube |
| 3. Alignment arrow | 10. Cathode plate |
| 4. Pirani tube | 11. Cathode tube |
| 5. Gasket | 12. Circlip |
| 6. Anode assembly | 13. Strike filament |
| 7. O-ring | |

6 Storage and disposal

6.1 Storage

Return the WRG to its protective packaging and store the WRG in clean dry conditions until required for use. Do not exceed the storage temperature conditions specified in [Section 2](#).

When required for use, prepare and install the WRG as described in [Section 3](#).

6.2 Disposal

Dispose of the WRG and any components safely in accordance with all local and national safety and environmental requirements.

Alternatively, the WRG and/or cables may be able to be recycled; contact Edwards or the supplier for advice (also see below).

The WRG and associated cables are within the scope of the European Directive on Waste Electrical and Electronic Equipment. Edwards offers European customers a recycling service for the WRG/cables at the end of the product's life. Contact Edwards for advice on how to return the WRG/cables for recycling.

Particular care must be taken if the WRG has been contaminated with dangerous process substances or if the WRG has been overheated or has been in a fire. Fluoroelastomers are used in the WRG; these are safe in normal use, but can decompose into dangerous breakdown products if heated to 260 °C and above.

This page has been intentionally left blank.

7 Service, spares and accessories

7.1 Introduction

Edwards products, spares and accessories are available from Edwards companies in Belgium, Brazil, China, France, Germany, Israel, Italy, Japan, Korea, Singapore, United Kingdom, U.S.A and a world-wide network of distributors. The majority of these centres employ Service Engineers who have undergone comprehensive Edwards training courses.

When maintaining this product, Edwards recommends using only Edwards maintenance and service kits.

Order spare parts and accessories from the nearest Edwards company or distributor. When ordering, please state for each part required:

- Model and Item Number of the equipment
- Serial number
- Item Number and description of the part.

7.2 Service

Edwards products are supported by a world-wide network of Edwards Service Centres. Each Service Centre offers a wide range of options including: equipment decontamination; service exchange; repair; rebuild and testing to factory specifications. Equipment which has been serviced, repaired or built is returned with a full warranty.

Local Service Centres can also provide Edwards engineers to support on-site maintenance, service or repair of equipment.

For more information about service options, contact the nearest Service Centre or other Edwards company.

7.2.1 Return the equipment or components for service

Before you send your equipment to us for service or for any other reason, you must send us a completed Declaration of Contamination of Vacuum Equipment and Components - Form HS2. The HS2 form tells us if any substances found in the equipment are hazardous, which is important for the safety of our employees and all other people involved in the service of your equipment. The hazard information also lets us select the correct procedures to service your equipment.

We provide instructions for completing the form in the Declaration of Contamination of Vacuum equipment and Components - Procedure HS1.

Download the latest documents from www.edwardsvacuum.com/HSForms/, follow the procedure in HS1, fill in the electronic HS2 form, print it, sign it, and return the signed copy to us.

7.3 Spares

Spares	Item Number
Electronics and magnet housing	
WRG-S-NW25	D14701800
WRG-SL-NW25	D14711800
WRG-D-NW25	D14702800
Body tube assembly NW25	D14701801
Body tube assembly DN40CF	D14703801
Electrode assembly kit *	D14701802
Pirani tube replacement kit †	D14701803
Full body tube service kit ‡	D14701804

* The electrode assembly kit contains one each of the following components: cathode plate, cathode tube, anode assembly, O-ring, plastic pirani housing, circlip, gasket and 4 screws and washers.

† The pirani tube replacement kit contains one each of the following components: pirani tube assembly, pirani housing, gasket and 4 screws and washers.

‡ The full body tube service kit contains one each of the following components: cathode plate, cathode tube, anode assembly, O-ring, pirani tube assembly, plastic pirani housing, circlip, gasket and 4 screws and washers.

7.4 Accessories

The cables suitable for use with the WRG are as follows. These cables are supplied with 8-way male electrical connectors on both ends.

Cable length		Item Number
0.5 m	18 inches	D40001005
1 m	3 feet	D40001010
3 m	10 feet	D40001030
5 m	15 feet	D40001050
10 m	30 feet	D40001100
15 m	50 feet	D40001150
25 m	80 feet	D40001250
50 m	150 feet	D40001500
100 m	325 feet	D40001999
9-way D type to FCC68 adapter		D40003100
Surge suppressor		D40006000

This page has been intentionally left blank.

