

Linear & Rotary

PowerProbe

(PP Series)

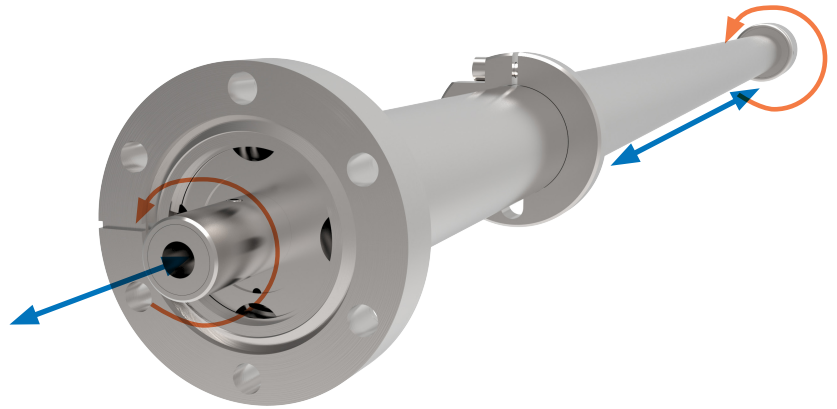

High performance magnetically-coupled combined linear/rotary devices, designed for sample transfer. Both linear and rotary motion of the sample achieved via a single actuator with stroke length from 304mm to 1524mm.

PP KEY ADVANTAGES

- » Unrivalled axial coupling strength
- » 4x torque compared to conventional devices
- » Exceptional axial stiffness
- » Zero backlash under low load
- » Bakeable to 250°C without removing any components

The PowerProbe provides both linear and rotary motion of the sample, via a single actuator.

The PowerProbe's powerful magnetic coupling technology provides performance far in advance of conventional probes on the market avoiding magnetic hysteresis and de-coupling issues suffered by traditional designs.

The high torque characteristics are achieved by utilising MagiDrive rotary coupling technology. Combined with a high thrust linear coupling, this ensures optimum drive performance on both axes. Therefore, actuation of the thimble in either axis will result in the precise transmission of this motion to the sample.

The PowerProbe can be fitted with a bakeable limit switch for the retracted position, aiding system interlocks.

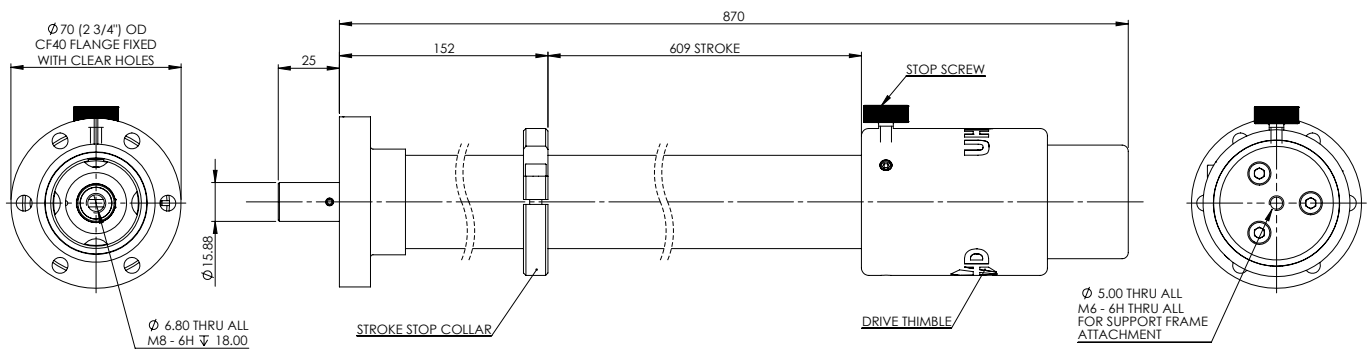

Example Dimensions (mm) PP40-609-H shown

Visit www.uhvdesign.com to configure, view and download 3D models



PP Technical Data

SPECIFICATION	VALUE
System mounting flange size up to 1219mm stroke	CF40 (2 3/4" OD) with clear holes
System mounting flange size 1524mm stroke	CF63 (4 1/2" OD) with clear holes
Magnetic rotary breakaway torque	4Nm (35 in-lbs)
Magnetic linear breakaway thrust	140 N (31.5 lbs)
Available stroke range	304mm to 1524mm
Output shaft - end interface details	15.99/15.88mm with M8 tapped hole
Bakeout temperature	250 °C with motor removed
Shaft radial run out	+/- 0.5mm
Shaft radial deviation (linearity) over full stroke	N/A
Maximum cantilevered load	20 Nm (177 in-lbs)
Maximum working axial load	90 N (20 lbs)
Retracted position switch - type	Bakeable micro switch wire to WD-020

PP Technical Performance

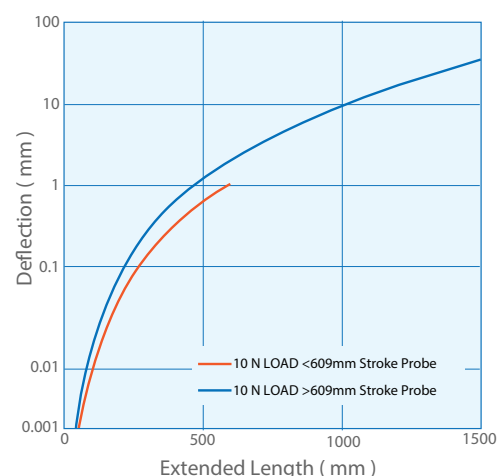
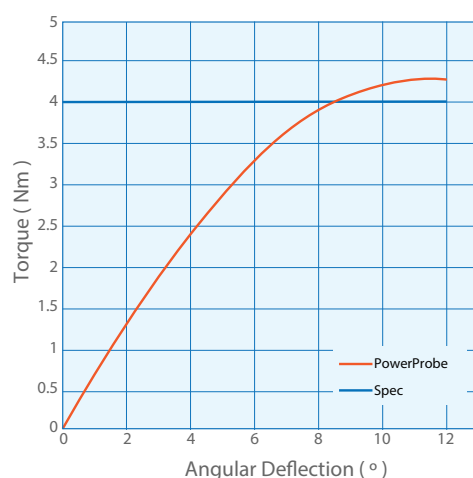
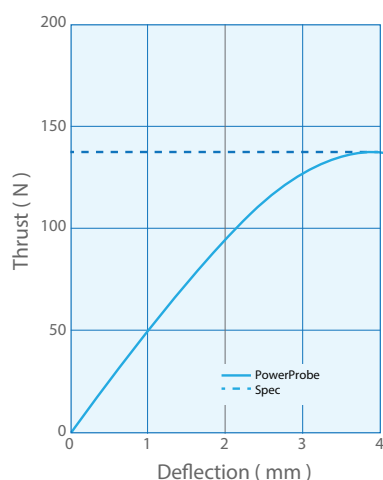

For more information:

UHV Design Ltd

Judges House, Lewes Road,
Laughton, East Sussex, BN8 6BN, UK
T: +44(0)1323 811188
E:sales@uhvdesign.com
www.uhvdesign.com

To find your nearest UHV Design representative please visit www.uhvdesign.com and click 'Contact'.