

Linear Shift Mechanism With Tilt

LSMT Series

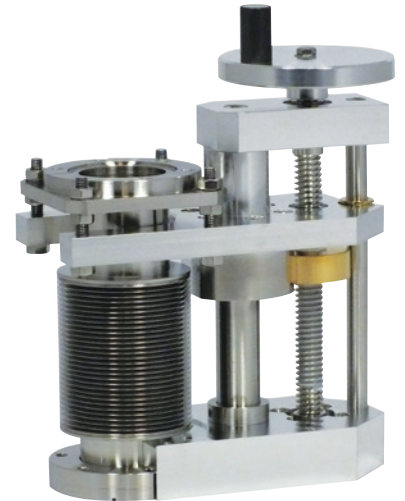

Smooth kinematic linear motion along the port axis (Z) with the additional facility to tilt the travelling flange so it serves as an integrated port aligner. This makes the LSMT ideal for applications where precise alignment with a fixed point is essential.

LSMT KEY ADVANTAGES

- » Up to 150mm stroke
- » +/- 2° tilt for final alignment
- » Adjustment via 4 threaded support shafts
- » Smooth kinematic motion
- » Bakeable to 250°C
- » Demountable bellows assembly

Linear Shift Mechanisms (LSMs) provide linear motion along the port axis (Z). Typical applications include the positioning of beamline filters, adjustment of sputter sources and deposition stages through to production style applications.

UHV Design has the largest range of LSMs in the world, ranging from CF35 to CF150 flanges, up to 1m stroke, tilt & X alignment versions with manual, pneumatic and motorisation options, all available with a range of position encoders. Bakeable to 250°C, the range is supplied on CF flanges and provides true UHV performance.

The LSMT is based on the standard LSM series with the additional facility to tilt the moving flange by +/- 2° for final alignment, acting as an integrated port aligner. Typically used on beamlines to align diagnostics or for ion/sputter source alignment. Adjustment is actuated via four threaded support shafts. All flanges in the series are supplied with tapped bolt holes on the base flange as standard.

Actuation methods

The series can be actuated with a manual handwheel, pneumatic cylinder, DC motor or stepper motor.

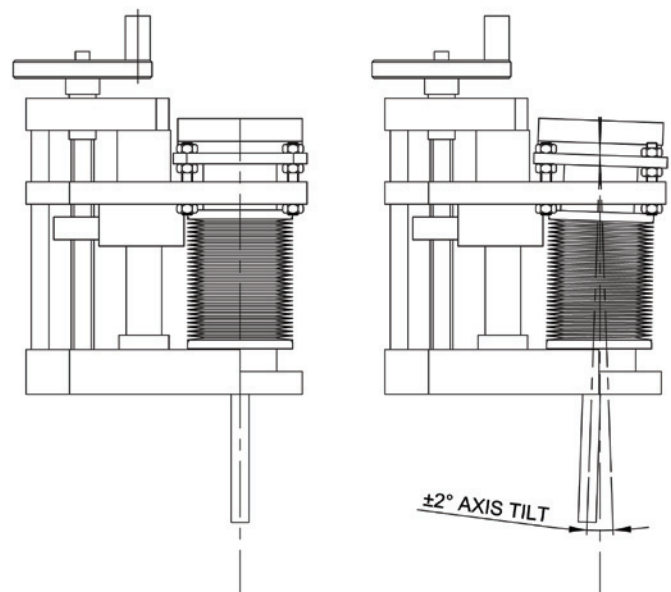

LSMT38 Technical Data

SPECIFICATION	VALUE
Travelling flange size	FC38 (2-3/4") metric tapped straddled
Standard fixed flange size	FC38 (2-3/4") metric tapped straddled
Stroke range	25 to 150 mm
Clear bore	38 mm
Leadscrew pitch	2.54mm (0.1")
Tilt angle of Travelling flange	+/-2 degrees
Max axial load on travelling flange	150N and 50N Pneumatic option
Maximum cantilevered moment	10 Nm
Flange alignment under vacuum	2 mrad (eg 2mm at 1m from travelling flange)
Linear scale option - resolution	1mm engraved scale or 0.01mm DLA option
Bakeout temperature	250 °C with motor/pneumatic cylinder /DLA removed
Pneumatic option - cylinder bore	32 mm
Pneumatic option - cylinder fitting	6mm tube push fit
Pneumatic option - cylinder switch	5-24V 2 wire reed switch
Pneumatic option - max linear speed	25mm / second
Stepper motor option - Z axis only	23 frame 8 wires 3A / phase
Standard stepper option - motor wiring	Flying leads
Standard stepper motor - switches	bakeable limit switches only not wired
Upgrade stepper motor - motor wiring	lemo socket to diagram 11-1-25
Upgrade stepper motor option - switches	bakeable limit and home switches with lemo socket wired to diagram WD-002
Stepper motor maximum linear speed	2.54 mm/second
Linear resolution per 1/2 step	0.000254 mm
DC motor option - Z axis only	24V dc brushed motor
DC motor option - motor wiring	2 pin generic plug to diagram WD-010
DC motor switches	bakeable limit switches only not wired
Upgrade DC motor option - switches	bakeable limit switches with lemo socket wired to diagram 11-6-03
DC motor maximum linear speed	4 mm/second
Motor gearbox type and ratio	spur and 25:1
Motor gearbox backlash	1 degree
Motorised Linear backlash under vacuum	0.0071mm

LSMT64 Technical Data

SPECIFICATION	VALUE
Travelling flange size	FC64 (4 1/2") metric tapped straddled
Standard fixed flange size	FC64 (4 1/2") metric tapped straddled
Stroke range	25 to 150 mm
Clear bore	65 mm
Leadscrew pitch	2.54mm (0.1")
Tilt angle of Travelling flange	+/-2 degrees
Max axial load on travelling flange	245N and 200N Pneumatic option
Maximum cantilevered moment	10 Nm
Flange alignment under vacuum	2 mrad (eg 2mm at 1m from travelling flange)
Linear scale option - resolution	1mm engraved scale or 0.01mm DLA option
Bakeout temperature	250 °C with motor/pneumatic cylinder /DLA removed
Pneumatic option - cylinder bore	63 mm
Pneumatic option - cylinder fitting	6mm tube push fit
Pneumatic option - cylinder switch	5-24V 2 wire reed switch
Pneumatic option - max linear speed	25mm / second
Stepper motor option - Z axis only	23 frame 8 wires 3.9A / phase
Standard stepper option - motor wiring	Flying leads
Standard stepper motor - switches	bakeable limit switches only not wired
Upgrade stepper motor - motor wiring	Built in UTO motor 23HT18C230 (3A / Phase)
Upgrade stepper motor option - switches	bakeable limit and home switches with lemo socket wired to diagram WD-002
Stepper motor maximum linear speed	1.27 mm/second
Linear resolution per 1/2 step	0.000127 mm
DC motor option - Z axis only	24V dc brushed motor
DC motor option - motor wiring	2 pin generic plug to diagram WD-010
DC motor switches	bakeable limit switches only not wired
Upgrade DC motor option - switches	bakeable limit switches with lemo socket wired to diagram 11-6-03
DC motor maximum linear speed	1.95 mm/second
Motor gearbox type and ratio	spur and 50:1
Motor gearbox backlash	1 degree
Motorised Linear backlash under vacuum	0.0071mm

For more information:

UHV Design Ltd
Judges House, Lewes Road,
Laughton, East Sussex, BN8 6BN, UK
T: +44(0)1323 811188
E:sales@uhvdesign.com
www.uhvdesign.com

To find your nearest UHV Design representative please visit www.uhvdesign.com and click 'Contact'.