

Instruction Manual

XDS Dry Pump



Description	Electrical Supply	Item Number
XDS35i Scroll Pump	100-120 V, 200-230 V, 50/60 Hz, Single Phase	A730-01-983





Declaration of Conformity

We, BOC Edwards,
Manor Royal,
Crawley,
West Sussex RH10 2LW, UK

declare under our sole responsibility that the product(s)

XDS35i Scroll Pump 100-120 V, 200-230 V, 50/60 Hz A730-01-983

to which this declaration relates is in conformity with the following standard(s)
or other normative document(s)

EN12100-2: 2003	Safety of Machinery: Basic Concepts, General Principles for Design.
EN1012-2: 1997	Compressors and Vacuum Pumps – Safety Requirements Part 2.
EN61010-1: 2001	Safety Requirements for Electrical Equipment for Measurement, Control and Laboratory Use.
EN13463-1: 2001	Non Electrical Equipment for Potentially Explosive Atmospheres.
C22.2 61010.1-04	Safety Requirements for Electrical Equipment for Measurement, Control and Laboratory use. Part 1: General Requirements.
UL61010-1 (2 nd edition)	Safety Requirements for Electrical Equipment for Measurement, Control and Laboratory use. Part 1: General Requirements.

following the provisions of

2006/95/EC	Low Voltage Directive.
2004/108/EC	Electromagnetic Compatibility Directive.
94/9/EC	Equipment for use in Potentially Explosive Atmospheres (ATEX Directive) (Category 3GD) Internal Atmospheres Only.
98/37/EC	Machinery Safety Directive.



II 3 G c IIB T4

INTERNAL ATMOSPHERES ONLY
Tech File Ref: MPTR 0271

B. D. Brewster, Technical Manager,
Burgess Hill Products

17th May 2007
BURGESS HILL

Date and Place

This product has been manufactured under a quality system registered to ISO9001

Contents

Section	Page
1	Introduction 1
1.1	Scope of this manual 1
1.2	ATEX directive implication 2
1.3	Description 3
1.4	Gas ballast control 4
1.5	Construction 4
2	Technical Data 5
2.1	Operating and storage conditions 5
2.2	Performance 5
2.2.1	General 5
2.2.2	Performance characteristics 5
2.3	Mechanical data 6
2.3.1	General 6
2.3.2	Vibration data 6
2.3.3	CSA approval environmental conditions 7
2.4	Electrical data 7
3	Installation 9
3.1	Safety 9
3.2	System design considerations 10
3.3	Unpack and inspect 12
3.4	Locate the pump 12
3.4.1	Mechanical fixing 12
3.5	Electrical installation 12
3.5.1	Check and configure the pump 12
3.5.2	Connect the pump to your electrical supply 13
3.6	Inlet and outlet connections 13
3.7	Leak test the system 14
4	Operation 15
4.1	Use of gas ballast control 15
4.1.1	Gas ballast control 15
4.2	Start up procedure 15
4.3	To achieve ultimate vacuum 16
4.4	To pump condensable vapours 16
4.5	Implication of ATEX directive 16
4.5.1	Introduction 16
4.5.2	Flammable/pyrophoric materials 16
4.5.3	Gas purges 16
4.6	Remote operation using 15 way D connector 17
4.7	Shut down 17
5	Maintenance 19
5.1	Safety information 19
5.2	Maintenance plan 19
5.3	Inspect and clean the inlet strainer 20
5.4	Inspect and clean the gas ballast control 21
5.5	Clean the external fan cover 22
5.6	Replace the tip seals 22

5.7	Test the motor condition	22
5.8	Fault-finding	22
5.8.1	The pump has failed to start or has stopped	22
5.8.2	The pump has failed to achieve the required performance	22
5.8.3	The pump is noisy	23
5.8.4	The pump surface temperature is high	23
5.8.5	The pumping speed is poor or if pump down time is too long	23
6	Storage and Disposal	25
6.1	Storage	25
6.2	Disposal	25
7	Service, Spares and Accessories	27
7.1	Introduction	27
7.2	Service	27
7.3	Accessories	27
7.3.1	Electrical cables	27
7.3.2	Silencer	27
7.3.3	Gas ballast adaptor	27
7.3.4	Solenoid operated pipeline valves	28
7.3.5	Tip seal and exhaust valve service kit	28
	Index	29

Illustrations

Figure	Page	
1	XDS35i scroll pump	3
2	Performance characteristics	6
3	Installation drawing	11
4	Logic interface schematic	18
5	Inlet strainer assembly	20
6	Gas ballast control assembly	21

Tables

Table		Page
1	Operating and storage conditions	5
2	General characteristics	5
3	Performance characteristics	5
4	General mechanical data	6
5	Vibration data	6
6	Electrical data	7
7	Recommended fuses	13
8	Pin status on the logic interface connector	18
9	Maintenance plan	20
10	Electrical cables	27
11	Solenoid operated pipeline valves	28

Associated publications

Publication title	Publication number
Vacuum Pump and Vacuum System Safety	P300-20-000

This page has been intentionally left blank.

1 Introduction

1.1 Scope of this manual

This manual provides installation, operation and maintenance instructions for the Edwards XDS35i Scroll pump. You must use your pump as specified in this manual. Read this manual before you attempt to install and operate your pump.

Important safety information is highlighted as WARNING and CAUTION instructions; you must obey these instructions. The use of WARNINGS and CAUTIONS is defined below.



WARNING

Warnings are given where failure to observe the instruction could result in injury or death to people.

CAUTION

Cautions are given where failure to observe the instruction could result in damage to the equipment, associated equipment and process.

The units used throughout this manual conform to the SI international system of units of measurement.

Pressures are stated as absolute pressures throughout this manual.

The following IEC warning labels appear on the pump:



Warning - refer to accompanying documentation.



Warning - risk of electric shock.



Warning - hot surfaces.

1.2 ATEX directive implication



This equipment is designed to meet the requirements of Group II Category 3 equipment in accordance with Directive 94/9/EC of the European Parliament and the Council of 23rd March 1994 on the approximation of the laws of the Member States concerning equipment and protective systems intended for use in potentially explosive atmospheres. (The ATEX Directive).

The ATEX Category 3 applies in respect of potential ignition sources internal to the equipment. An ATEX Category has not been assigned in respect of potential ignition sources on the outside of the equipment as the equipment has not been designed for use where there is an external potentially explosive atmosphere.

There is no potential source of ignition within the pump during normal operation but there may be potential sources of ignition under conditions of foreseeable and rare malfunction as defined in the Directive. Accordingly, although the pump is designed to pump flammable materials and mixtures, operating procedures should ensure that under all normal and reasonably foreseeable conditions, these materials and mixtures are not within explosive limits. Category 3 is considered appropriate for the avoidance of ignition in the case of a rare malfunction which allows flammable materials or mixtures to pass through the pump whilst within their explosive limits.

When flammable materials are present within the equipment you must:

- Not allow air to enter the equipment.
- Ensure the system is leak tight.

Further details can be obtained by contacting Edwards UK on +44 1293 528844.

Figure 1 - XDS35i scroll pump

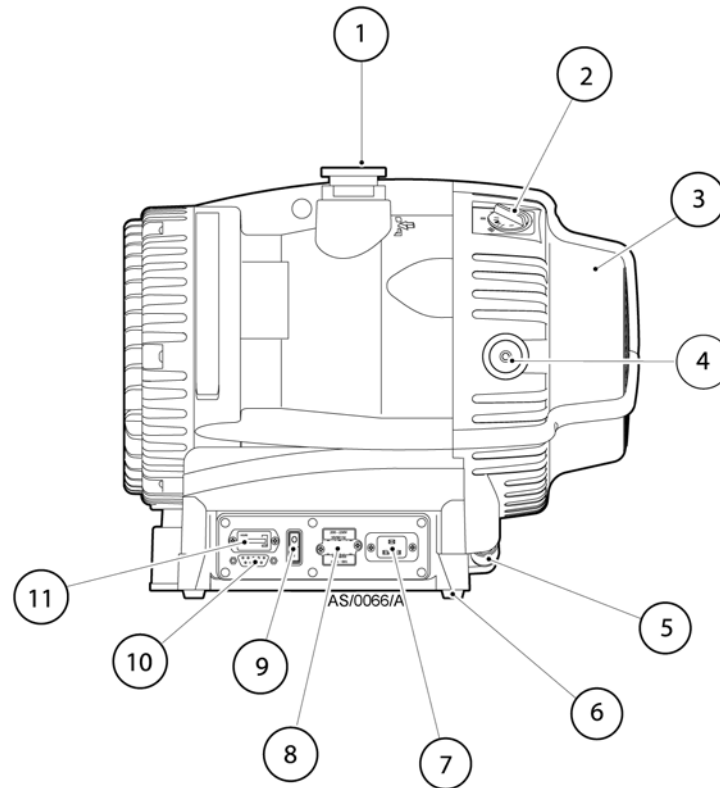

- | | |
|------------------------|------------------------------------|
| 1. NW40 inlet port | 7. Electrical connector |
| 2. Gas ballast control | 8. Voltage changeover switch cover |
| 3. Cooling fan | 9. On/Off switch |
| 4. NW25 exhaust port | 10. 15 way connector |
| 5. Fan connector | 11. Hour counter |
| 6. Rubber feet | |

1.3 Description

The XDS35i pump is shown in Figure 1. Refer to Figure 1 for item numbers in brackets in the following descriptions.

The XDS pump is a compact, reliable vacuum pump which is suitable for use on vapour handling processes. The XDS pump may be used for some pumping applications involving corrosive substances and particulates; for information on pumping flammable gases, please refer to Section 4.5 and contact Edwards for any further assistance.

The body of the pump includes a fixed scroll and an orbiting scroll. The orbiting scroll is controlled by the electric motor through an eccentric cam on the motor drive shaft. The movement of the orbiting scroll, meshed with the fixed scroll, forms successive crescent shaped volumes in the pump. Gas that enters the pump through the inlet is compressed by the movement of the orbiting scroll and swept towards the centre of the fixed scroll. The compressed gas enters the exhaust port near the centre of the stationary scroll and is exhausted from the pump through the outlet.

The XDS is a truly dry vacuum pump, as all the bearings, with their hydrocarbon lubricant, are isolated from the vacuum space.

The inlet of the pump has a NW40 (1) inlet and inlet strainer.

The pump mechanism is driven directly by a three phase electric motor. The motor is controlled by an inverter, which manages the supply of current to the motor in accordance with operating conditions, and allows the pump to be connected to a single phase supply. The voltage changeover switch (beneath the voltage changeover switch cover, refer to [Figure 1](#), item 8) must be set to the correct position in accordance with the power supply being used, refer to [Section 3.5.2](#).

The XDS35i is designed to run from atmospheric pressure however, if the inlet pressure exceeds 100 mbar for an extended period, the inverter may reduce the motor speed. The pump will speed up again after the pressure is reduced.

The pump is air-cooled by a fan (3) mounted at the opposite end to the motor. The fan will run on for one minute after the pump is switched off. The XDS35i incorporates a thermal protection device that will stop the motor in the event of thermal overload e.g. high ambient temperature. The pump will restart after it has cooled down.

The pump is mounted on rubber feet (6).

The pump is fitted with an hours counter (11), which indicates the total time that the pump has run.

1.4 Gas ballast control

To pump high vapour loads, gas ballast can be delivered into the pump to prevent condensation of the vapour carried by the pumped gases.

Air can be introduced to the low vacuum stages through the gas ballast control (2). Alternatively, an inert gas such as nitrogen can be supplied through a suitable external valve and by using the appropriate adaptor, available as an accessory, refer to [Section 7.3.3](#).

The gas ballast control has three positions:

- Closed (position '0')
- Low flow (position 'I')
- High flow (position 'II')

1.5 Construction

The pump scrolls are made of anodised aluminium. The motor housing is aluminium. All surfaces of the pump which are exposed to the pumped gases are free from copper, zinc and cadmium.

Other materials of construction include fluorocarbon elastomer, nitrile, chemically resistant polymers, nickel and stainless steel.

The tip seal is a PTFE composite material.

2 Technical Data

2.1 Operating and storage conditions

Table 1 - Operating and storage conditions

Operating and storage conditions	XDS35i
Ambient temperature range (operation)	+10 °C to +40 °C
Maximum surface temperature of pump body (Depending on ambient temperature)	+40 °C to +70 °C
Maximum humidity (operation)	90% RH
Ambient temperature range (storage)	-30 °C to +70 °C

2.2 Performance

2.2.1 General

Table 2 - General characteristics

General	XDS35i
Suckback protection (no solenoid valve on inlet)	By exhaust valve
Maximum initial pressure rise with no gas ballast flow (mbar l)	5
Maximum displacement (m ³ /hr)	44
Maximum pumping speed (m ³ /hr)	35
Maximum permitted inlet pressure and gas ballast inlet pressure (barg)	0.5
Maximum permitted outlet pressure (barg)	1
Leak tightness (mbar l s ⁻¹)	<1 x 10 ⁻⁶

2.2.2 Performance characteristics

The position of the gas ballast control defines the performance characteristics of the pump. These performance characteristics are listed in Table 3.

Table 3 - Performance characteristics

Pump	Gas ballast control position	Ultimate total pressure (mbar)	Gas ballast flow (l min ⁻¹)
XDS35i	0	<0.01	-
	1	<0.02	3
	2	<10.0	12

Figure 2 - Performance characteristics

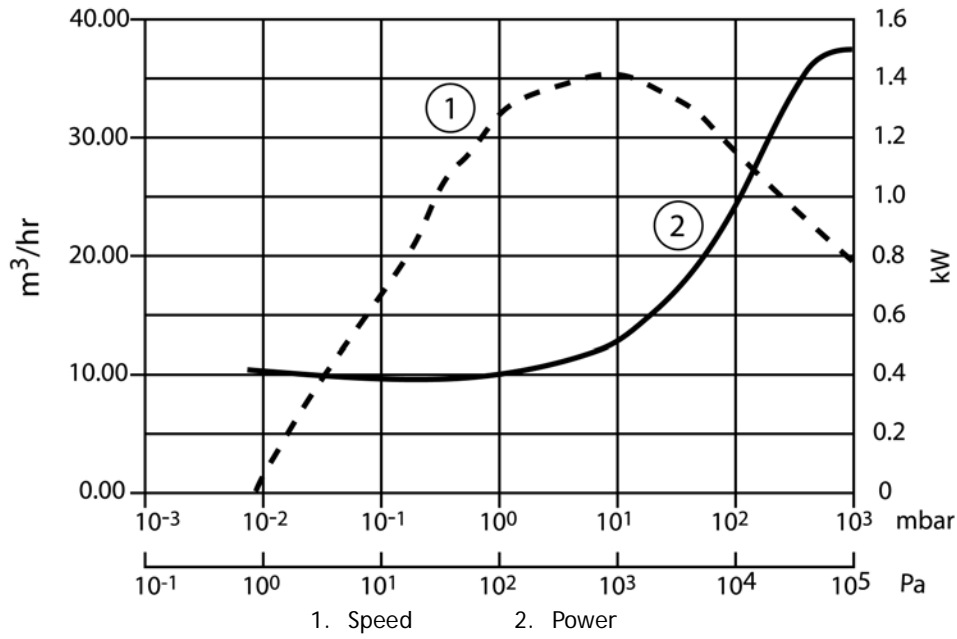

2.3 Mechanical data

2.3.1 General

Table 4 - General mechanical data

Parameter	Units	XDS35i
Overall dimensions (L x W x H)	mm	476 x 333 x 396
Maximum tilt angle	degree	10
Nominal rotational speed	rpm	1750
Mass	kg	48
Inlet connection		NW40
Outlet connection		NW25
Degree of protection (IEC60529)		IP44

2.3.2 Vibration data

Table 5 - Vibration data

Parameter	XDS35i
Sound pressure, measured at ultimate vacuum 1 metre from the end of the pump to ISO 11201	57 dB (A)
Vibration: measured at the inlet port (ISO3744)	Class 1C... < 4.5 mms ⁻¹ (rms)

2.3.3 CSA approval environmental conditions

CSA approval environmental conditions	
Pollution	Pollution degree 2
Installation	Installation category II
Altitude restriction	Max 2000 m
Area of use	Indoor use

2.4 Electrical data

Table 6 - Electrical data

Pump	Supply (V)	Phase	Frequency (Hz)	Power (W) at ultimate vacuum	Current (A)
XDS35i	200/230	Single	50/60	520 *	5
	100/120	Single	50/60	520 *	8.5

* Refer to Figure 2.

This page has been intentionally left blank.

3 Installation

3.1 Safety



WARNING

Obey the safety instructions given below and take note of appropriate precautions. If you do not, you can cause injury to people and damage to equipment.



WARNING

The Edwards XDS35i pump is not recommended for pumping explosive gases or hazardous substances.

You must ensure that the XDS35i pump is suitable for your application. If you have any doubt about the suitability of the XDS35i pump for your application, refer to the Edwards guidelines on vacuum pump and vacuum system safety (see associated publications at the end of the contents list at the front of this manual).



WARNING

Prevent any part of the human body coming into contact with the vacuum.

A suitably trained and supervised technician must perform the installation of the XDS35i pump. Obey the safety instructions listed below when you install the XDS pump, especially when you connect the pump into an existing system. Details of the specific safety precautions are given at the appropriate point in the instructions.



WARNING

Use suitable lifting equipment to move the XDS35i pump. The mass of the pump is approximately 48 kg.

- Mechanical lifting equipment should be attached to the lifting eye on the pump.
- Loose slings should not be used to lift the XDS35i.



WARNING

Take care when moving the pump into position. The pump's weight makes it difficult to slide and movement should be attempted using two people.

- Wear the appropriate safety clothing when you come into contact with contaminated components. Dismantle and clean contaminated components inside a fume cupboard.
- Vent and purge your vacuum system before you start installation work.
- Ensure that the installation technician is familiar with the safety procedures that relate to the products handled by the pumping system.
- Disconnect the other components in the pumping system from the electrical supply so that they cannot be operated accidentally.

3.2 System design considerations

Consider the following points when you design your pumping system:

Use a suitable valve to isolate the pump from your vacuum system if you need to allow the pump to warm up before pumping condensable vapours or if you need to maintain vacuum when the pump is switched off.

Avoid high levels of heat input into the pump from the process gases, otherwise the pump may overheat, and cause the thermal overload device to open.

If you use the pump in a high ambient temperature and have a high gas throughput, the temperature of the pump body may approach 70 °C and you must fit suitable guards to prevent contact with hot surfaces.

Make sure that the exhaust pipeline cannot become blocked. If you have an exhaust isolation valve, make sure that you cannot operate the pump with the valve closed.

Provide for a purge of inert gas when you shut down the pumping system, to dilute dangerous gases to safe concentrations.

Figure 3 - Installation drawing

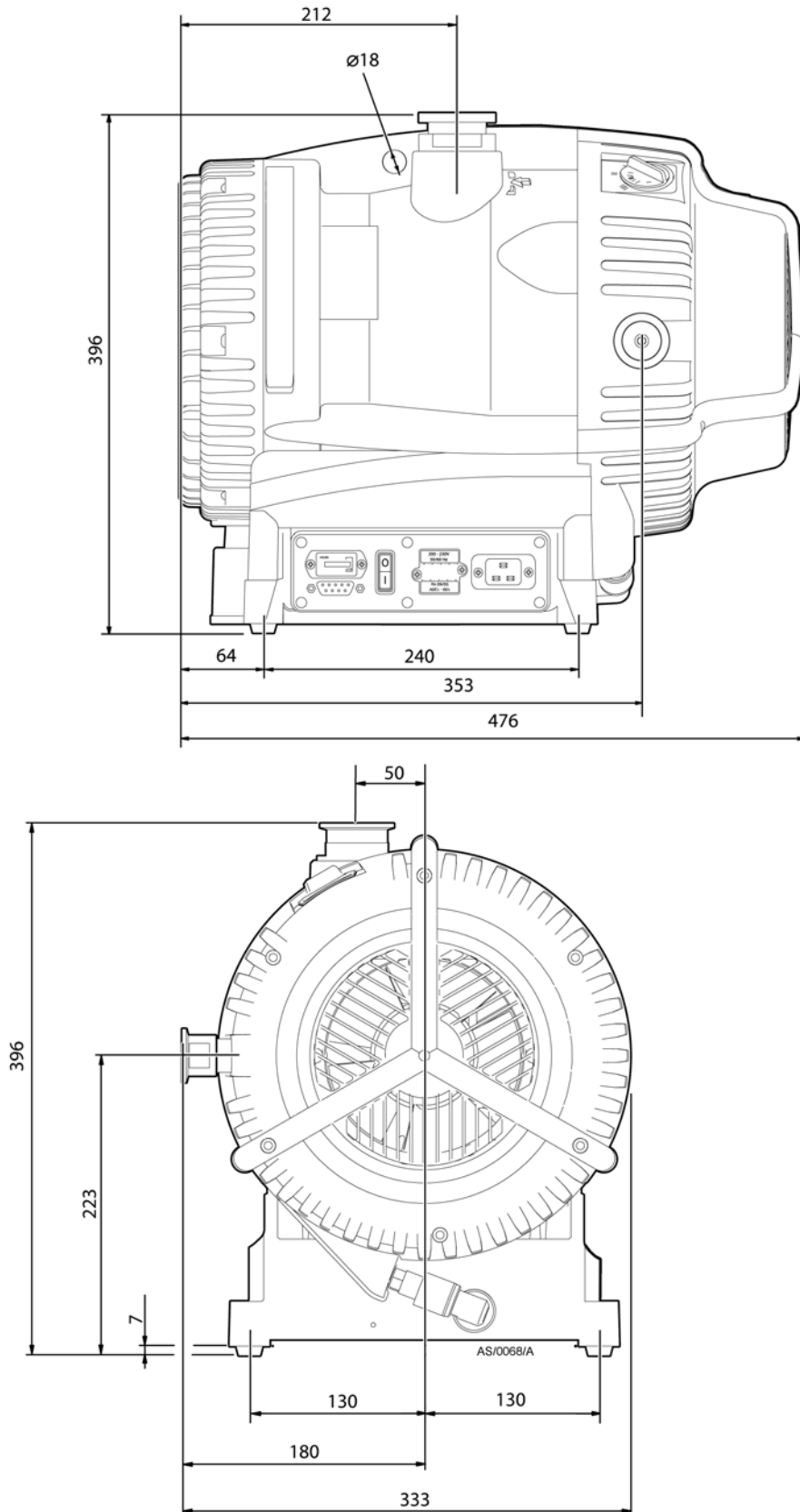

3.3 Unpack and inspect



WARNING

Use suitable lifting equipment to move the XDS35i pump. The mass of the pump is approximately 48 kg.

Remove all packing materials, remove the pump from its packing box, remove the protective covers from the inlet and outlet ports and inspect the pump. If the pump is damaged, notify your supplier and the carrier in writing; state the item number of the pump together with your order number and your supplier's invoice number. Retain all the packing materials for inspection. Do not use the pump if it is damaged. If the pump is not to be used immediately, replace the protective covers. Store the pump in suitable conditions, as described in Section 6.1. Refer to Section 6.2 for disposal of materials.

3.4 Locate the pump



WARNING

If the pump is to be used on the floor of a work area, position the power lead and the exhaust and inlet hoses with care. Ensure that personnel in the area are aware of any obstructions around the pump.

Provide a firm, level platform for the pump. Locate the pump so that the gas ballast control and the on/off switch are accessible.

If your pump will be located inside an enclosure, make sure that there is adequate ventilation at both ends of the pump, so that the ambient temperature around the pump does not exceed 40 °C. There must be a minimum space of 25 mm between the pump and the enclosure walls.

3.4.1 Mechanical fixing

Note: If you wish to secure the pump you may do so using the four holes located on each corner of the pump base, we recommend you use M8 bolts.

3.5 Electrical installation

3.5.1 Check and configure the pump

CAUTION

Before changing the voltage, unplug the power supply. Ensure that the pump is correctly configured for your electrical supply otherwise you may cause damage.

Ensure that the voltage shown on the voltage indicator (refer to Figure 1, item 8) on the motor cover corresponds with your electrical supply voltage. If it does not, you must change the configuration of the pump motor to match your supply voltage; use the procedure below.

1. Undo the two screws and lift off the voltage indicator moulding.
2. Rotate the voltage indicator moulding so that the correct voltage is uppermost.
3. Replace the two screws.

3.5.2 Connect the pump to your electrical supply



WARNING

Ensure that the electrical installation of the XDS pump conforms with your local and national safety requirements. It must be connected to a suitably fused and protected electrical supply with a suitable earth point.

The following fuse ratings should be used (refer to Table 7).

Table 7 - Recommended fuses

Area	Voltage	Rating
UK	230 V	13 A
Europe	230 V	16 A
US	110 V	20 A
Japan	100 V	20 A

CAUTION

If using an overload circuit breaker it must be of a time lag type because of high start up current.

CAUTION

If using an earth leakage device e.g. an RCD, use at least a 30 mA rated unit to avoid trip during start up.

The pump will automatically restart after restoration of the power supply following power failure.

Make the electrical connections to the pump motor with an IEC60320 cable socket (C19) that satisfies your local electrical standards.

3.6 Inlet and outlet connections



WARNING

If pumping dangerous gases or vapours, connect the exhaust to a suitable treatment plant to prevent the discharge of dangerous gases and vapours to the surrounding atmosphere.



WARNING

If pumping for a prolonged period above 100 mbar inlet pressure, use an exhaust silencer (refer to Section 7.3.2) or connect to an appropriate exhaust line.

Refer to Figure 1. Before you connect the pump to your vacuum system, remove the plastic cap from the inlet and the exhaust, and ensure that the inlet strainer is fitted to the pump inlet port. Use appropriate NW40 vacuum fittings for connection to your system.

Take note of the following information when you connect the pump to your vacuum system.

- To minimise noise and exhaust emissions, it is recommended that the pump is connected to an exhaust line or a silencer (refer to Section 7.3.2).
- For optimum pumping speeds, ensure that the pipeline connected to the pump inlet is as short as possible and has a suitable internal diameter.

- Support the vacuum pipeline to prevent loading of the coupling joints.
- If necessary, incorporate flexible bellows in your system pipelines to reduce the transmission of vibration and to prevent loading of the coupling joints. If you use flexible bellows, you must ensure that you use bellows that have a maximum pressure rating which is greater than the highest pressure that can be generated in your system. We recommend that you use Edwards bellows.
- Incorporate an inlet isolation valve in the pipeline from the vacuum system to the pump, so that you can isolate the vacuum system from the pump when it is switched off and prevent the suckback of process gases and debris into the vacuum system.
- Ensure that the sealing surfaces are clean and scratch-free.

We recommend that you use an exhaust extraction system suitable for use with all of the process gases you will pump. Ensure that the exhaust extraction system cannot become blocked or obstructed when the pump is operating.

A small amount of tip seal wear product may collect in the exhaust duct of the pump. The dust may be blown out with the initial burst of air after the pump has been vented. This is quite common and the amount of dust seen will reduce over time.

3.7 Leak test the system

After you have installed the XDS pump, leak test the system and seal any leaks found.

4 Operation

4.1 Use of gas ballast control

You can use the gas ballast control to optimise the performance of the scroll pump for your application. The performance characteristics of the pump with the different ballast settings are shown in [Section 2.2.2](#). You can change the position of the gas ballast control when the pump is off or when the pump is operating.

4.1.1 Gas ballast control

Use the gas ballast control to change the amount of air introduced into the final stage of the pump. Use of gas ballast will reduce the condensation of vapours in the pump; the condensates would contaminate the pump. You can turn the gas ballast control to select one of the three positions, as follows:

To select no gas ballast, turn the control position to '0'. Use this setting:

- to achieve ultimate vacuum
- to pump dry gases.

To select low flow gas ballast, turn the control to position 'I'. Use this setting:

- to pump low concentrations of condensable vapours
- to decontaminate the pump.

To select high flow gas ballast, turn the control to position 'II'. Use this setting:

- to pump high concentrations of condensable vapours
- to clear excess vapours after processing.

4.2 Start up procedure



WARNING

Ensure that your system design does not allow the exhaust pipeline to become blocked.

CAUTION

A fine dust may be emitted from the exhaust of the scroll pump during start up, particularly when the pump is new or if new tip seals are fitted. Refer to [Section 5.6](#) for further information when fitting new tip seals.

Use the procedure below to start up the pump:

1. Ensure that any vacuum system isolation valve is closed (if fitted).
2. Connect a suitable lead from the power supply to the electrical socket at the side of the pump.
3. Switch on the electrical supply to the pump, using the on / off switch on the motor.
4. Always use the on / off switch to start / stop the pump.
5. Open the vacuum system isolation valve (if fitted).

4.3 To achieve ultimate vacuum

In order to achieve the best possible vacuum, the pump should be operated with the gas ballast control on position '0'. However, if the pump, or elements of the vacuum system it is attached to, are new or have been newly fitted, some atmospheric moisture may be present. If atmospheric moisture is present, run the pump with the gas ballast control in position 'I' or 'II' for 20 minutes before switching to position '0'. If moisture is allowed to remain, the performance of the pump will be impaired.

4.4 To pump condensable vapours

Select a suitable gas ballast setting (gas ballast control in position 'I' or 'II') when there is a high proportion of condensable vapours in the process gases. This will assist the vapours to pass through the pump without condensing and keep the pump performance from degrading.

4.5 Implication of ATEX directive

4.5.1 Introduction

This equipment is designed to meet the requirements of Group II Category 3 equipment in accordance with Directive 94/9/EC of the European Parliament and the Council of 23rd March 1994 on the approximation of the laws of the Member States concerning equipment and protective systems intended for use in potentially explosive atmospheres. (The ATEX Directive).

The ATEX Category 3 applies in respect of potential ignition sources internal to the equipment. An ATEX Category has not been assigned in respect of potential ignition sources on the outside of the equipment as the equipment has not been designed for use where there is an external potentially explosive atmosphere.

There is no potential source of ignition within the pump during normal operation but there may be potential sources of ignition under conditions of foreseeable and rare malfunction as defined in the Directive. Accordingly, although the pump is designed to pump flammable materials and mixtures, operating procedures should ensure that under all normal and reasonably foreseeable conditions, these materials and mixtures are not within explosive limits. Category 3 is considered appropriate for the avoidance of ignition in the case of a rare malfunction which allows flammable materials or mixtures to pass through the pump whilst within their explosive limits.

4.5.2 Flammable/pyrophoric materials

When flammable or pyrophoric materials are present within the equipment you must:

- Not allow air to enter the equipment.
- Ensure the system is leak tight.
- Dilute any flammable gases or vapours by using an inert purge (e.g. N₂) to the pump inlet and/or gas purge to reduce their concentration the pump and exhaust line to less than one quarter of their published lower explosive limits (LEL).
- Prevent the condensation of flammable vapours within the pump mechanism and exhaust line by using an inert gas purge to the pump gas ballast connection.

4.5.3 Gas purges

CAUTION

The following actions must be taken to ensure that the gas being pumped stays out of the flammable range.

The inert gas purge should be switched on to remove air from the pump and exhaust before the process starts. The purge flow can be switched off at the end of the process only after any remaining flammable gases or vapours have been purged from the pump and exhaust line.

If liquids that produce flammable vapours could be present in the pump foreline then the inert gas purge to the XDS35i should be left on all the time this liquid is present. Flammable liquids could be present in the foreline as a result of condensation or may be carried over from the process.

When calculating the flow rate of inert gas required for dilution, consider the maximum flow rate for the flammable gases/vapours that could occur. For example, if a mass flow controller is being used to supply flammable gases to the process, you should assume a flow rate for flammable gases that could arise if the mass flow controller is fully open. The inert gas purge flow rate should be continually measured and if the flow rate falls below that required, then the flow of flammable gases or vapours to the pump must be stopped.



WARNING

If you use the nitrogen purges to dilute dangerous gases to a safe level, ensure that the system shuts down if the nitrogen supply to the XDS35i fails.

We recommend you obtain and read Vacuum Pump and Vacuum System Safety publication no P300-20-000 available from Edwards or your supplier.

4.6 Remote operation using 15 way D connector

It is possible to operate the pump remotely using the 15 way D type connector fitted on the panel at the side of the pump. (Refer to [Figure 1](#)).

The 15 way D connector is insulated to ensure that it remains protected in the event of a single fault condition.

The controls available are as follows:

- On/Off
- Boost (Run pump at 116%)
- Idle (Run pump at 67%)
- Run (Runs pump at standard speed 100%)
- OK Signal

[Figure 4](#) shows which connections to make to enable these functions.

The power On/Off switch ([Figure 1](#), item 9) should be in the Off position for remote operation.

To completely remove electrical power from the pump, the plug should be removed from the electrical connector ([Figure 1](#), item 7).

4.7 Shut down

Use the procedure below to shut down the pump:

1. If shutting the pump down prior to a period of storage, remove any process gases by running on high flow gas-ballast for at least one hour.
2. Close any vacuum system isolation valve to prevent suckback into the vacuum system (where fitted).
3. Switch off the pump. When the pump is switched off the fan will continue to run for 1 minute.
4. Vent the XDS35i by the gas ballast control or valve on the inlet.

Figure 4 - Logic interface schematic

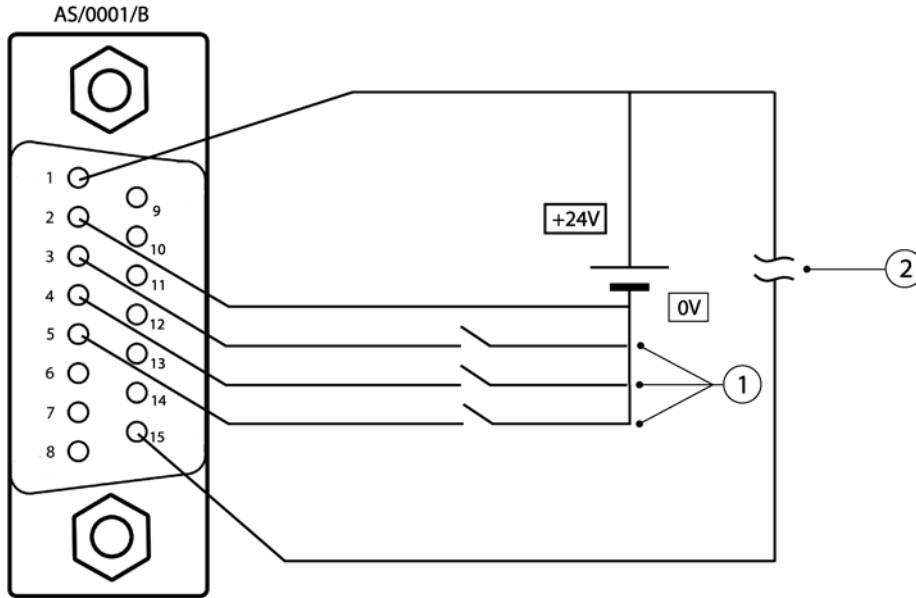

1. Speed control pins 3, 4 and 5
Maximum current per pin = 7 mA when linked to pin 1 (24 V)
2. Pump healthy signal
Signal high = normal (maximum permissible current = 100 mA)

Table 8 - Pin status on the logic interface connector

Mode	Speed percentage	Pumping speed (m ³ h ⁻¹)	Pin 1	Pin 3	Pin 4	Pin 5
Normal	100%	35	24 V	Link	open	open
Boost	116%	41	24 V	Link	Link	Link
Idle	67%	23	24 V	Link	Link	open

The tolerance of the power supply can be ±10%. Make sure all the unused pins are not connected.

5 Maintenance

5.1 Safety information



WARNING

Obey the safety instructions given below and take note of appropriate precautions. If you do not, you can cause injury to people and damage to equipment.



WARNING

Wait one minute for capacitor discharge after disconnecting the power supply before working on the pump.

The XDS35i pump is designed to require little user maintenance. Observe the following guidelines when carrying out maintenance on your pump:

- Ensure that maintenance is done by a suitably trained and supervised technician. Obey your local and national safety requirements.
- Ensure that the maintenance technician is familiar with the safety procedures which relate to the products processed by the pumping system.
- Check that all the required parts are available and are of the correct type before you start work. Refer to Section 7.3.5.
- Disconnect the pump and other components from the electrical supply so that they cannot be operated accidentally.
- Allow the pump to cool before you start maintenance work.
- Do not re-use internal 'O' rings.



WARNING

The pump may be contaminated with the process chemicals that have been pumped during operation. If so, ensure that the pump is decontaminated before maintenance and that you take adequate precautions to protect people from the effects of dangerous substances if contamination has occurred.

- Do not touch or inhale the thermal breakdown products of fluorinated materials which may be present in the pump if the pump has been heated to 260 °C and above. Fluorinated materials are safe in normal use but can decompose into very dangerous substances (which may include hydrofluoric acid) if they are heated to 260 °C and above. The pump may have overheated if it was misused or if it was in a fire. Health and Safety Data sheets for fluorinated materials used in the pump are available on request; contact your supplier or Edwards.

5.2 Maintenance plan

More frequent maintenance may be required if the pump is used to pump aggressive gases and vapours, such as solvents, organic substances and acids, or if the pump is operated continuously at the higher end of its operating temperature range.

Table 9 - Maintenance plan

Operation	Frequency	Refer to Section
Inspect and clean inlet strainer	Annually	5.3
Inspect and clean the gas ballast control	Annually	5.4
Clean the external fan cover	Annually	5.5
Replace the tip seal and exhaust valve	Annually or as required	5.6
Test the motor / drive condition	15000 hours	5.7
Replace the bearings	35000 hours	Refer to Edwards

5.3 Inspect and clean the inlet strainer

Whenever you disconnect the pump from your vacuum system, we recommend that you:

- Remove any debris trapped by the inlet strainer (in the inlet port).
 - Inspect the inlet strainer and if necessary, clean it with a cleaning solution suitable for the substances pumped. Refit the inlet strainer before you reconnect the pump to your vacuum system.
1. Refer to **Figure 5**. Disconnect your vacuum system from the pump inlet-port (3) and remove the centring-ring and strainer assembly (1) and the 'O' ring (2). Inspect the centring-ring and the 'O' ring. If they are clean, continue at Step 5. If they are not clean, continue at Step 2.
 2. Remove the 'O' ring (2) from the centring-ring and strainer assembly (1). Do not allow the 'O' ring to come into contact with the cleaning solution.
 3. Wash the centring-ring and strainer assembly in a suitable cleaning solution and allow it to dry.
 4. If necessary, wipe the 'O' ring with a clean, dry, lint-free cloth.
 5. Refit the centring-ring and strainer assembly and the 'O' ring to the inlet-port. Refit your vacuum system to the pump inlet-port.

Figure 5 - Inlet strainer assembly

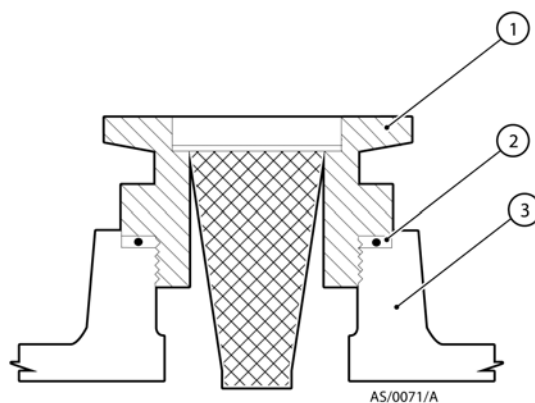

1. Centring ring and strainer
2. 'O' ring
3. Pump inlet-port

5.4 Inspect and clean the gas ballast control

Note: The gas ballast filter element (Figure 6, item 7) is retained in its seating with adhesive; do not try to remove it.

1. Refer to Figure 6. Turn the gas ballast control to the high flow position (II).
2. Push the control down against the compression spring (6) as far as it will go, then turn the control anti-clockwise slightly to release the bayonet lugs (5) and remove the control (1).
3. If necessary, wipe the control with a clean, dry, lint-free cloth and check that the air-hole (3) is not blocked. If necessary, clean the foam with warm soapy water and allow to air dry.
4. Refit the control into the gas ballast inlet and ensure that the compression spring locates correctly between the bayonet lugs.
5. Push the control down as far as it will go and then turn the control clockwise slightly until the bayonet lugs engage correctly.
6. Reset the gas ballast control to the required position.

Figure 6 - Gas ballast control assembly

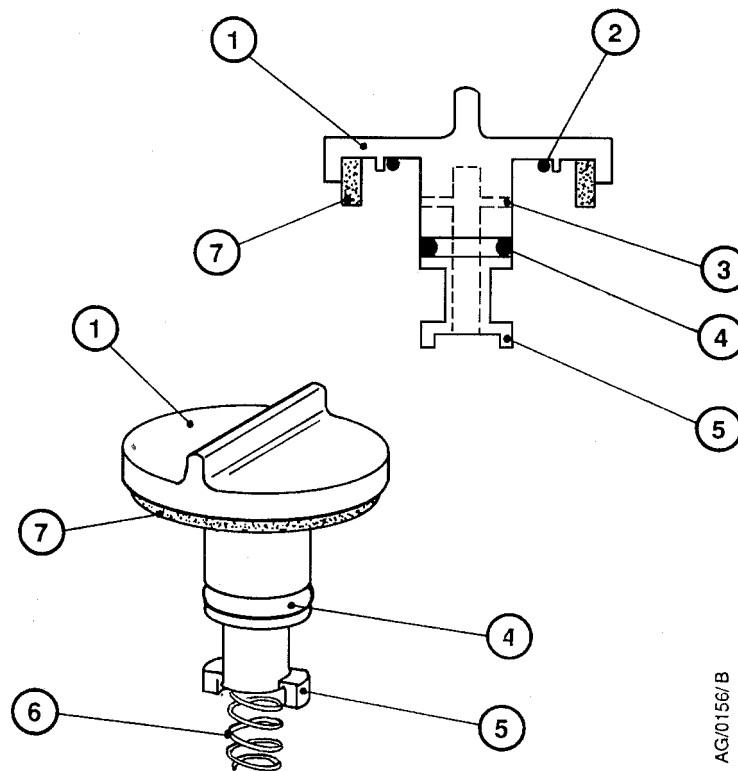

AG/0156/B

- | | |
|------------------------|-----------------------|
| 1. Gas ballast control | 5. Bayonet-lugs |
| 2. 'O' ring | 6. Compression spring |
| 3. Air-hole | 7. Filter element |
| 4. 'O' ring | |

5.5 Clean the external fan cover

If the fan cover is not kept clean, the air flow over the pump can be restricted and the pump may overheat.

1. Switch off the pump and disconnect it from the electrical supply.
2. Use a dry cloth and a soft brush to remove dirt and deposits from the fan cover.

5.6 Replace the tip seals

This instruction is applicable to the XDS35i replacement tip seal kit (contained in minor service kit, refer to Section 7.3.5) that must be fitted.

5.7 Test the motor condition

CAUTION

Do not flash test the XDS35i or damage to the inverter may result.

Test the earth continuity and the insulation resistance of the pump motor, in accordance with local regulations for the periodic testing of electrical equipment.

We recommend that the earth continuity is less than 0.1Ω and the insulation resistance is greater than $2M\Omega$. (Reference EN61010-1).

If the pump fails these tests, you must contact Edwards.

5.8 Fault-finding

5.8.1 The pump has failed to start or has stopped

- The electrical supply fuse has blown.
- The electrical supply voltage does not match that for which the inverter input has been configured.
- The inverter drive has not reset after an over temperature event. Disconnect the mains supply and wait for at least one minute and attempt to restart.
- The motor is faulty.
- Fan not working or not connected.
- The ambient temperature is too high.
- The cooling air supply is insufficient or is too hot.
- The process gas is too hot or the throughput is too high.

5.8.2 The pump has failed to achieve the required performance

- To close the gas ballast, turn the control to position '0'. Use this setting in order to achieve the best possible vacuum. If the pump has been used to pump condensable vapours or is to pump a large chamber that has been exposed to atmospheric air (water vapour), it may be necessary to run for at least an hour on high flow gas ballast 'II'.
- If the electrical supply voltage is more than 10% below the lowest voltage specified on the voltage indicator, the pump may operate yielding a degraded vacuum performance.

- There is a leak in your vacuum system.
- Your pressure measurement technique or gauge head is unsuitable or gives an incorrect indication of pressure.
- Your vacuum fittings are dirty or damaged.
- The inlet strainer is blocked.
- There is a blockage or high pressure in the exhaust line.
- The pump contains traces of process vapours.
- The pump is outside the specified range of operating conditions.
- The gas ballast control is not properly closed.
- The tip seals need replacing.
- The inverter is current limiting the supply.
- The pump is in idle mode.

5.8.3 The pump is noisy

- The pump is contaminated with solid particles.
- The bearings are worn.
- Following tip seal replacement, the pump has not been vented and a build up of eroded tip seal dust is reducing running clearances. Refer to [Section 5.6](#) for further information.

5.8.4 The pump surface temperature is high

- The ambient temperature is too high.
- The cooling air supply is insufficient or is too hot.
- The process gas is too hot or the throughput is too high.

5.8.5 The pumping speed is poor or if pump down time is too long

- The connecting pipelines are too small in diameter.
- The connecting pipelines are too long.
- The inlet strainer is blocked.
- There is a leak in the system.
- The inverter is current limiting the supply.
- The pump is in idle mode.

This page has been intentionally left blank.

6 Storage and Disposal

6.1 Storage

Use the following procedure to store the pump:

1. Shut down the pump as described in [Section 4.7](#).
2. Disconnect the pump from the electrical supply.
3. Place and secure protective covers over the inlet and outlet ports.
4. Store the pump in cool, dry conditions until required for use. When required, prepare and install the pump as described in [Section 3](#).

6.2 Disposal

Dispose of the pump and any components from it safely in accordance with all local and national safety and environmental requirements.

If this pump is to be returned to Edwards Vacuum Technology for disposal/ investigation. Particular care must be taken with components that have been contaminated with dangerous process substances.



WARNING

Do not incinerate fluoroelastomer seals, tip seal material and 'O' rings.

This page has been intentionally left blank.

7 Service, Spares and Accessories

7.1 Introduction

Edwards products, spares and accessories are available from Edwards companies in Belgium, Brazil, Canada, France, Germany, Hong Kong, Italy, Japan, Korea, Switzerland, UK, USA and a world-wide network of distributors. The majority of these centres employ Service Engineers who have undergone comprehensive Edwards training courses. Order spare parts and accessories from your nearest Edwards company or distributor. When you order, state for each part required:

- Model and item number of your equipment.
- Serial number (if any).
- Item number and description of part.

7.2 Service

Edwards are supported by a worldwide network of Edwards Service Centres. Each Service Centre offers a wide range of options including: equipment decontamination; service exchange; repair; rebuild and testing to factory specifications. Equipment which has been serviced, repaired or rebuilt is returned with a full warranty.

Your local Service Centre can also provide Edwards engineers to support on-site maintenance, service or repair of your equipment.

For more information about service options, contact your nearest Service Centre or other Edwards company.

7.3 Accessories

7.3.1 Electrical cables

Refer to [Table 10](#). The following electrical cables are available as accessories and should be used to connect the XDS35i to your electrical supply:

Table 10 - Electrical cables

Product description	Ordering information
Lead Assembly, 13 A, C19, UK	A505-05-003
Lead Assembly, 16 A, C19, Europe	A505-06-003
Lead Assembly, 15 A, C19, USA	A505-07-003
Lead Assembly, 20 A, C19, No Plug	A505-08-003

7.3.2 Silencer

A silencer is available for the pump. The code number for the silencer is A505-97-001. Refer to [Section 3.6](#) for guidance on its use. A silencer spares kit, code number A505-97-801 is also available.

7.3.3 Gas ballast adaptor

Fit the gas-ballast adaptor in place of the gas-ballast control on the pump. The adaptor allows you to connect a controlled supply of inert gas to the pump. Gas-ballast adaptor A505-02-000.

7.3.4 Solenoid operated pipeline valves

Fit the pipeline valve between your vacuum system and the pump inlet to provide additional system protection when the pump is switched off. The following valves are available as accessories and are recommended. (Refer to Table 11).

Table 11 - Solenoid operated pipeline valves

Product description	Ordering information
PV40EK Valve, 220-240 V 50/60 Hz, Aluminium	C414-01-000
PV40EK Valve, 220-240 V 50/60 Hz, Steel	C414-02-000
PV40EK Valve, 110-127 V 50/60 Hz, Aluminium	C414-03-000
PV40EK Valve, 110-127 V 50/60 Hz, Steel	C414-04-000

7.3.5 Tip seal and exhaust valve service kit

This kit contains all the necessary components to replace the tip seal and exhaust valve. Tip seals should be replaced as a pair, and only simple tools are required. The kit part number is A730-01-801.

Index

A

Accessories	27
ATEX directive implication	2

C

Clean the external fan cover	22
Connect the pump to your electrical supply	13
Construction	4

D

Description	3
Disposal	25

E

Electrical data	7
Electrical installation	12

F

Fault-finding	22
Flammable/pyrophoric materials	16

G

Gas ballast control	4
Gas purges	16
General characteristics	5

I

Implication of ATEX directive	16
Inlet and outlet connections	13
Inspect and clean the gas ballast control	21
Inspect and clean the inlet strainer	20
Installation	9
Introduction	1

L

Leak test the system	14
Locate the pump	12

M

Maintenance	19
Maintenance plan	19
Mechanical data	6

O

Operating and storage conditions	5
Operation	15

P

Performance characteristics	5
-----------------------------------	---

R

Remote operation using 15 way D connector	17
Replace the tip seals	22

S

Safety	9
Scope and definitions	1
Service	27
Shut down	17
Spares	27
Start up procedure	15
Storage	25
System design considerations	10

T

Technical data	5
Test the motor condition	22

U

Unpack and inspect	12
Use of gas ballast control	15

V

Vibration data	6
----------------------	---

This page has been intentionally left blank.