

## All-Metal Angle Valve

### Double acting pneumatic actuator

This manual is valid for the valve ordering number(s):  
 57040- . E14/24/34/44  
 57044- . E14/24/34/44

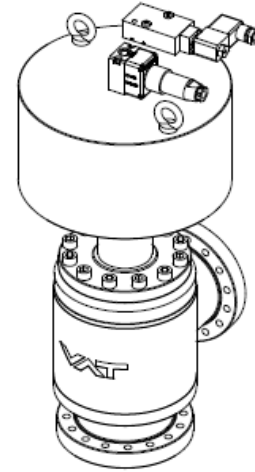

The fabrication number is indicated on each product as per the label below (or similar):

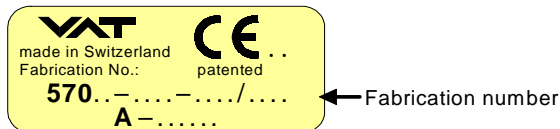

#### Symbollegende:



Erklärung sorgfältig lesen, bevor weitere Schritte unternommen werden!



Körperteile und Gegenstände von der Ventilöffnung fernhalten!



Achtung!



Heisse Oberflächen; nicht berühren!



Produkt entspricht EG-Richtlinien sofern zutreffend!



Gespannte Federn und/oder Luftpolster sind Gefahrenquellen!



Strom- & Pressluftleitungen abhängen.  
 Spannungsführende Teile nicht berühren!



Handschuhe tragen!



Read these «**Installation, Operating & Maintenance Instructions**» and the enclosed «**General Safety Instructions**» carefully before you start any other action!



**Installation, Operating & Maintenance Instructions**  
**Series 57.0, DN 100 - 160 (4" - 6")**

---

Imprint:

**Manufacturer** VAT Vakuumventile AG, CH-9469 Haag, Switzerland

Website  
www.vatvalve.com

Phone  
+41 81 771 61 61

Fax  
+41 81 771 48 30

Email  
CH@vatvalve.com

**Publisher** VAT Vakuumventile AG, CH-9469 Haag, Switzerland

**Editor** VAT Vakuumventile AG, CH-9469 Haag, Switzerland

**Print** VAT Vakuumventile AG, CH-9469 Haag, Switzerland

**Copyright** © VAT Vakuumventile AG 2008

No part of these Instructions may be reproduced in any way (photocopies, microfilms or any other reproduction processes) nor may it be manipulated with electronic systems, duplicated or distributed without written permission from VAT. Offenders are liable to pay damages.

The original VAT firmware and updated state of the art versions of the VAT firmware are intended for use with VAT products. The VAT firmware contains a limited, time unlimited user license. The VAT firmware may not be used for purposes other than those intended nor is it permitted to make copies of the VAT firmware. In particular, it is strictly forbidden to give copies of the VAT firmware to other people.

The use of trade names, brand names, trademarks, etc. in these Instructions does not entitle third parties to consider these names to be unprotected and to use them freely. This is in accordance with the meaning of the laws and acts covering brand names and trademarks.



**Contents:**

1	Use of product .....	4
1.1	Technical data .....	4
2	Installation.....	4
2.1	Unpacking .....	4
2.2	Installation into the system.....	4
2.3	Connections .....	5
2.3.1	Compressed air connection .....	5
2.3.2	Electrical connection .....	6
3	Operation .....	8
3.1	Normal operation.....	8
3.2	Operation under increased temperature .....	8
3.2.1	Bake out.....	8
3.3	Behavior in case of compressed air pressure drop.....	9
3.4	Behavior in case of power failure .....	9
3.4.1	Emergency operation at power failure .....	9
4	Trouble shooting .....	10
5	Maintenance & repairs .....	10
5.1	Preventive maintenance.....	11
6	Drawing.....	12
7	Spare parts .....	13
8	Warranty .....	17



## 2.3 Connections

### 2.3.1 Compressed air connection



- Connect compressed air only if
- valve is installed into the vacuum system
  - moving parts cannot be touched

Connection: internal thread R 1/8" (1/8" NPT for USA)

Connection for compressed air supply: ⊙

Compressed air pressure (min. - max. overpressure): 4 - 5 bar / 55 - 70 psig

Use only clean, dry or slightly lubricated air!

#### Without solenoid

Connections «open» and «close» for air supply

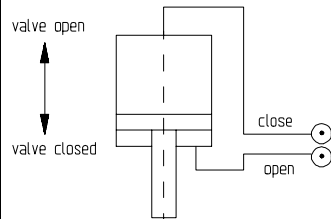

#### With solenoid

Connection «1» for air supply, connections «3» and «5» for exhaust

##### Standard solenoid

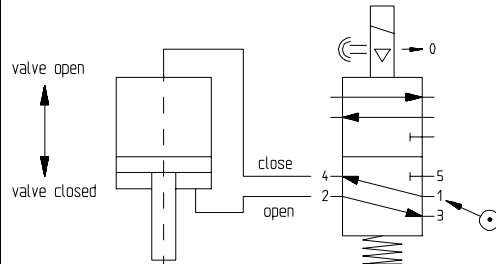

##### Solenoid for impulse actuation

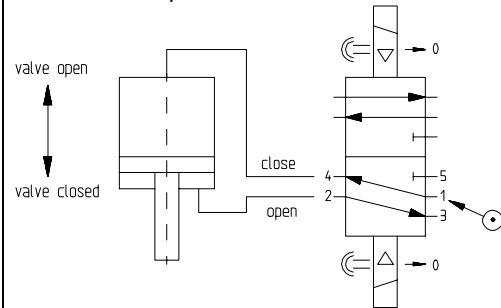

### 2.3.2 Electrical connection



Do not touch electrical parts under voltage!



Connect electrical power only if  
 - valve is installed into the vacuum system  
 - moving parts cannot be touched

Verify that mains voltage matches voltage stated on the solenoid!

Sockets for position indicator and solenoid are supplied with the valve.

Wiring diagrams:

#### Solenoids

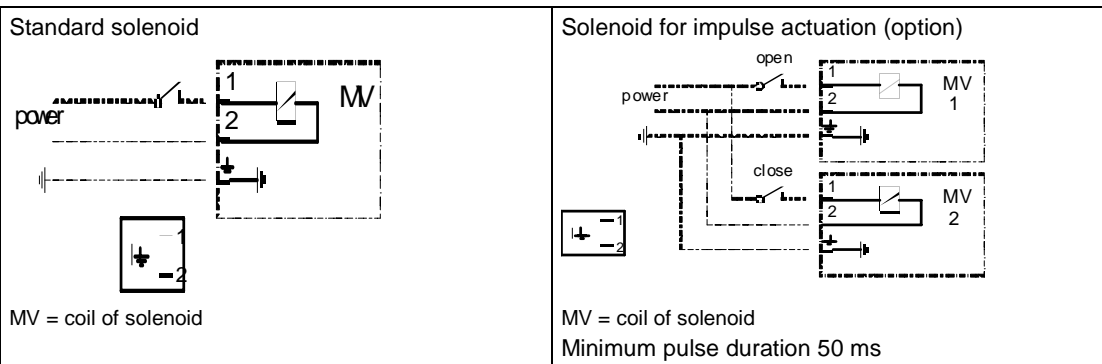

#### Position indicators for max. 80°C — contact rating ≤ 50 V AC / DC; ≤ 1.2 A

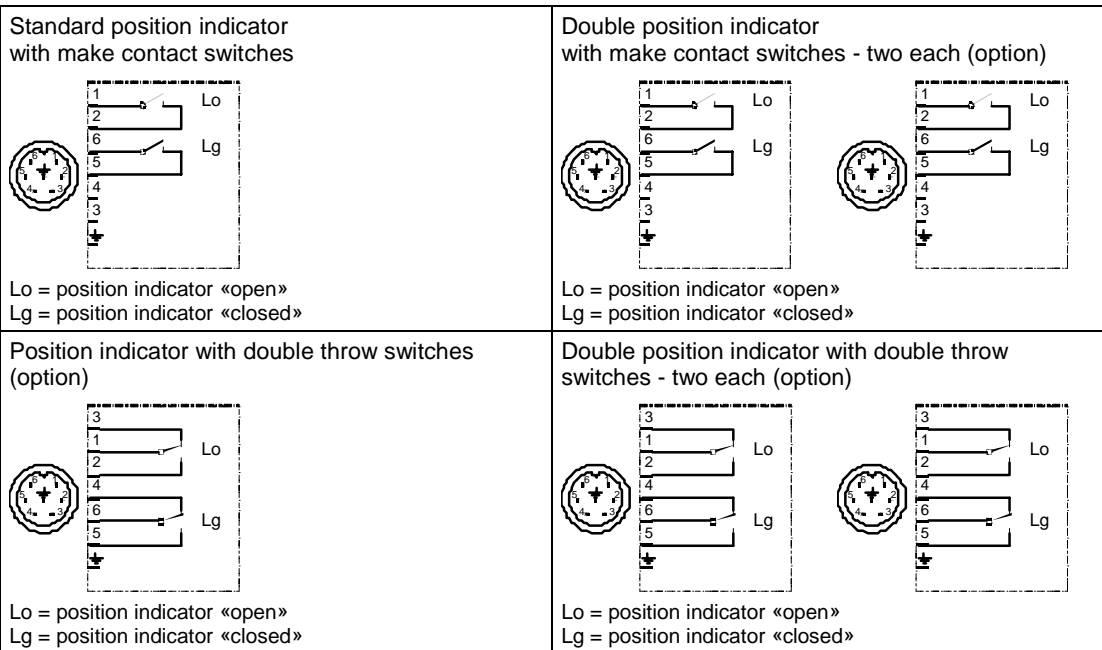

**Position indicators for max. 80°C — contact rating  $\leq 50$  V AC / DC;  $\leq 1.2$  A**

Position indicator radiation resistant 10E6Gy with make contact switches

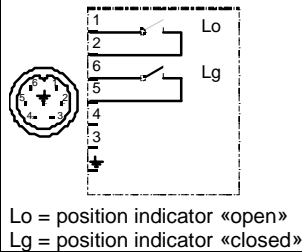

**Position indicators for max. 200°C — contact rating  $\leq 50$  V AC / DC;  $\leq 1$  A**

Single position indicator (option)

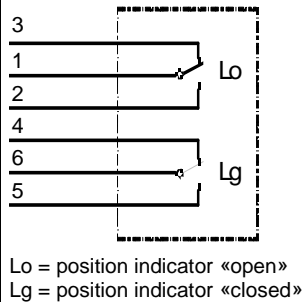

Double position indicator (option)

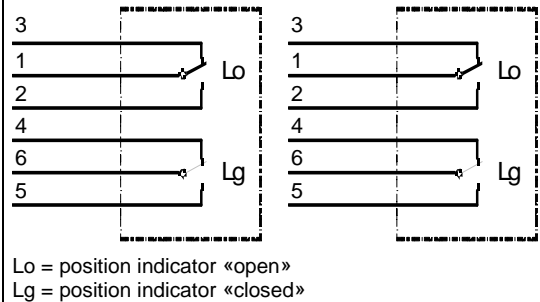

**Position indicator for max. 80°C — contact rating  $\leq 50$  V AC / DC;  $\leq 1$  A**

Common plug for pos. indicator and solenoid, pos. indicator with make contact switches (option)

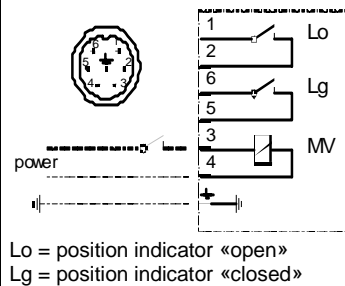



## 3 Operation

### 3.1 Normal operation

Opening of closed valve

- without solenoid:
  - air supply to connection «open»
  - air release through connection «closed»
- with standard solenoid:
  - supply specified control voltage to the coil
- with impulse solenoid:
  - supply an impulse of specified control voltage to the coil for opening (pulse duration min. 50 ms)

Closing of open valve

- without solenoid:
  - air supply to connection «close»
  - air release through connection «open»
- with standard solenoid:
  - release control voltage
- with impulse solenoid:
  - supply an impulse of specified control voltage to the coil for closing (pulse duration min. 50 ms)

### 3.2 Operation under increased temperature

See «1.1 Technical data»

#### 3.2.1 Bake out

Valve body:	450°C open / 350°C closed
Actuator:	200°C (for max. 200h)
Position indicator:	80°C (option: 200°C)
Solenoid	80°C
Heating and cooling rate:	60°C/h

Operate the valve only after the bake-out temperature has been stable for two hours. If actuation during bake-out is required, the heating and cooling rate from 200°C to 350°C must not exceed 30°C/h.

Temperature differences exceeding 30°C throughout the valve are not allowed. They may affect the performance of the valve.



### 3.3 Behavior in case of compressed air pressure drop

Valve closed: valve position is undefined  
 Valve open: valve position is undefined

### 3.4 Behavior in case of power failure

Standard solenoid: Valve closes

Solenoid for impulse actuation (option): Valve position does not change, a started movement will be completed.

#### 3.4.1 Emergency operation at power failure

Option: Solenoids with an emergency operation (slotted screw) to operate the valve in case of a power failure (with compressed air available)

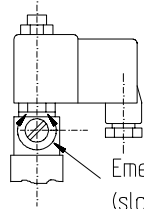
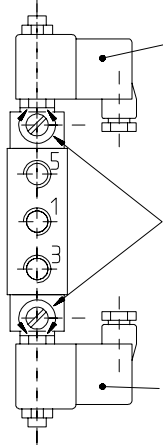
<p><b>Standard solenoid</b></p> <p>To <u>close</u> the valve:              Turn the slotted screw counter-clockwise to its stop</p> <p>To <u>open</u> the valve:              Turn the slotted screw clockwise to its stop</p> <p>For remote operation make sure that the slotted screw is turned counter-clockwise to its stop.</p>	 <p>Emergency operation (slotted screw)</p>
<p><b>Solenoid for impulse actuation</b></p> <p>To <u>close</u> the valve:              Turn the slotted screw (coil «closed») clockwise to its stop. If the valve is closed, turn the screw back to its original position.</p> <p>To <u>open</u> the valve:              Turn the slotted screw (coil «open») clockwise to its stop. If the valve is open, turn the screw back to its original position.</p> <p>For remote operation make sure that both slotted screws are turned counter-clockwise to their stop (original position).</p>	 <p>Coil open</p> <p>Emergency operation (slotted screw)</p> <p>Coil closed</p>



## 4 Trouble shooting

Failure	Check	Action
Valve mechanism does not move:	Power available?	Check voltage!
	Compressed air available?	Check air pressure!
	Slotted screw of solenoid in proper position?	Check slotted screw!

If you need any further information, please contact one of our service centers. You can find the addresses on our website: <http://www.vat.ch>

## 5 Maintenance & repairs

Under clean operating conditions, the valve does not require any maintenance during the specified cycle life. Contamination from the process may influence the function and requires more frequent maintenance.

Before carrying out any maintenance or repairs, please contact VAT. It has to be individually decided whether the maintenance/repair can be performed by the customer or has to be carried out by VAT. The fabrication number on the valve

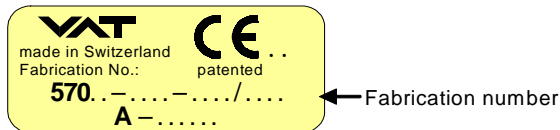

has always to be specified.

All supplies (e. g. compressed air, electrical power) must be disconnected for removal/installation of the valve from/into the system and for maintenance work.



Even with disconnected supply, loaded springs and/or air cushions in cylinders can be potential hazards.



Keep fingers and objects away from the valve opening!

Products returned to VAT must be free of harmful substances such as e.g. toxic, caustic or microbiological ones. If products are radioactively contaminated, fill in the VAT form «Contamination and Radiation Report» and send it with the product. The form is available at VAT. The maximum values indicated in the form must not be exceeded.



## 5.1 Preventive maintenance

**Instruction how to change the VATRING** (Don't touch inside valve parts without gloves)

- Open the valve and remove the bonnet screws (Pos.66).
- Remove valve insert and bonnet seal (Pos.36/2).
- When opening or tightening screw (Pos.64) the bellows must be protected against turning (torsion) → shown on the next page.
- Remove VATRING.
- Take a lint free tissue dabbed with alcohol and clean all sealing surfaces (plate, bonnet, body seat and VATRING).
- Check sealing surfaces (visually) for scratches.
- Clean VATRING and plate with clean and dry compressed air.
- Place VATRING on sealing surface of the plate.
- Align VATRING parallel with the frontal of the plate.
- Place holding ring on top of plate.
- Insert screw (Pos.64), protect bellow against turning, tighten screw (torque see list).
- Place new bonnet seal (fig.36/2) exactly like shown on next page (fitting position)!
- Put valve insert back into valve body and tighten bonnet screws in crosswise order (torque see list).

Nominal I.D. (DN)	DN 100	DN160
closing torque of screw with venting hole (pos. 64)	15 Nm	15 Nm
closing torque of bonnet screw (pos. 66)	35 Nm	35 Nm

## 6 Drawing

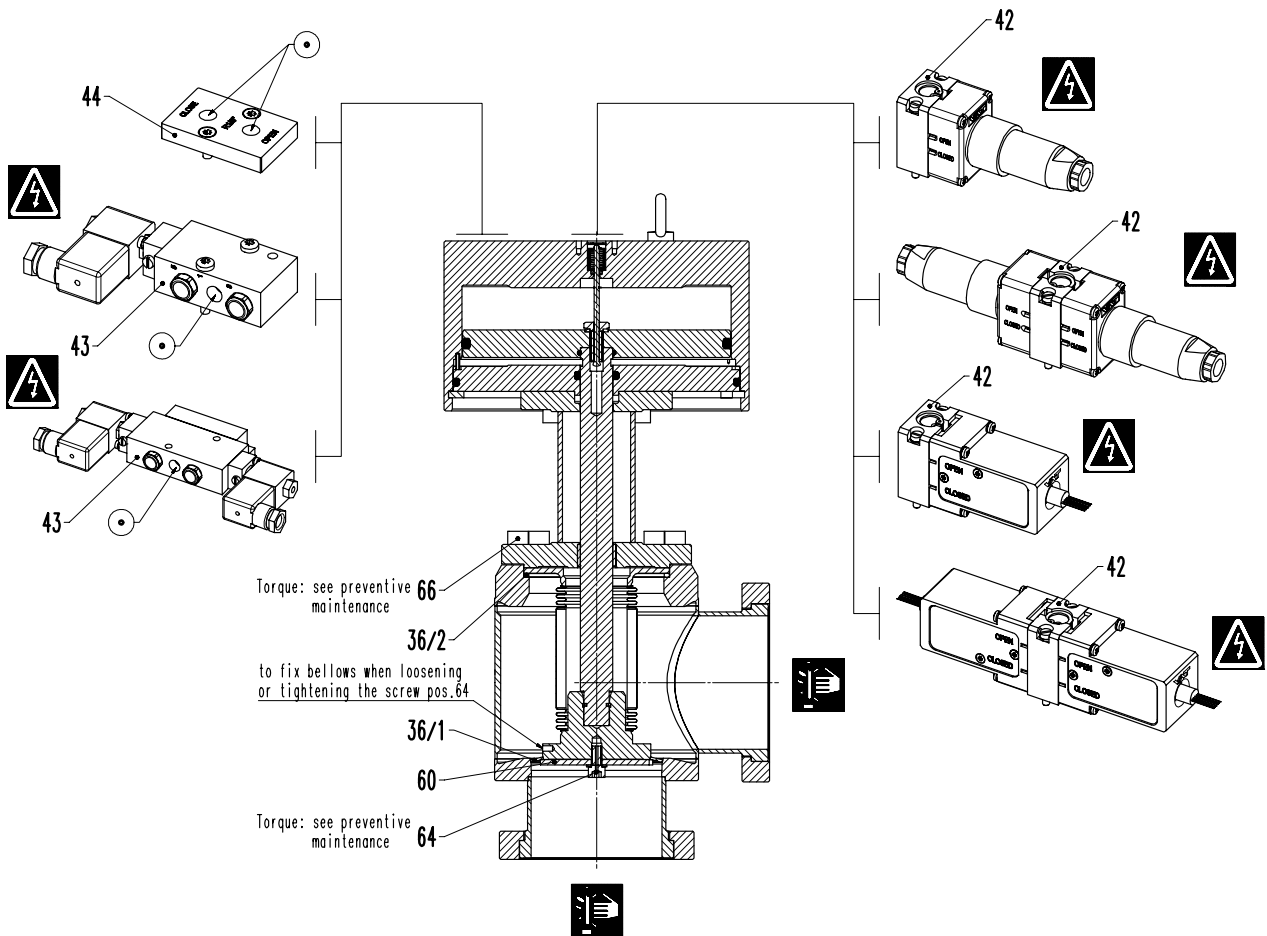



## 7 Spare parts



Please specify the **fabrication number of the valve** (see yellow label on valve) when ordering spare parts. This is to ensure that the appropriate spare parts are supplied.

The item numbers refer to the drawing on page 12.

Item	Description	Qty	Part / Ordering number	
			DN 100	DN 160
36/1	VATRING	1	39986-01	35774-01
36/2	Bonnet seal	1	51914-08	213816
36	Vacuum seal kit, consisting of VATRING and bonnet seal	1	83921-R1	215875
37	Pneumatic seal kit (Elastomer seals inside the pneumatic actuator)	1	232832	219947
60	Holding ring	1	99914-01	213794
64	Screw with venting hole	1	214314 / 15 Nm	214314 / 15 Nm
66	Treated hexagon socket head cap screw	12 16	N-5019-839 / 35 Nm	N-5019-839 / 35 Nm

**Air connection kit (solenoid on customer's site)**

Item	Description	Version	Qty.	Part No.
44	Connection kit	standard	1	81427-R1
		actuator for 10 <sup>6</sup> Gy	1	86069-R1
44/1	Plate		1	81428-01
44/2	Screw		2	N-6013-463
44/3	O-ring	standard	2	N-7100-016
		actuator for 10 <sup>6</sup> Gy	2	N-7115-016

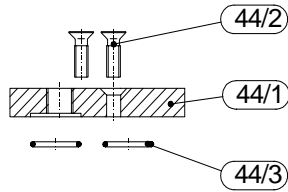

**Solenoid kit (5/2-way standard)**

Item	Description	Qty.	Part No.
43	Solenoid kit	1	80993-R1
43/1	Solenoid	1	N-7501-502
43/2	Socket	1	N-8501-300
43/3	Sound absorber	2	N-7705-001
43/4	Coil**	1	N-7510-2**
43/5	O-ring	2	N-7100-016
43/6	Screw	2	N-6024-562

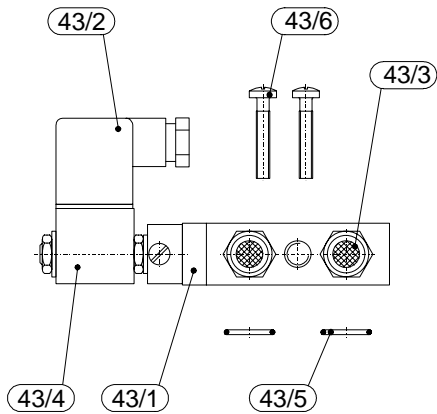

\*\* Specify voltage!  
 (e.g. N-7510-2-**220V 50Hz**)

**Solenoid kit (5/2-way impulse actuation)**

Item	Description	Qty.	Part No.
43	Solenoid kit	1	84569-R1
43/1	Connection plate	1	93708-01
43/2	Hollow screw	2	N-5060-010
43/3	Screw	2	N-6013-462
43/4	Gasket	4	N-7016-010
43/5	O-ring	2	N-7100-016
43/6	Solenoid	1	N-7502-504
43/7	Sound absorber	2	N-7705-001
43/8	Socket	2	N-8501-300
43/9	Coil**	2	N-7510-2**

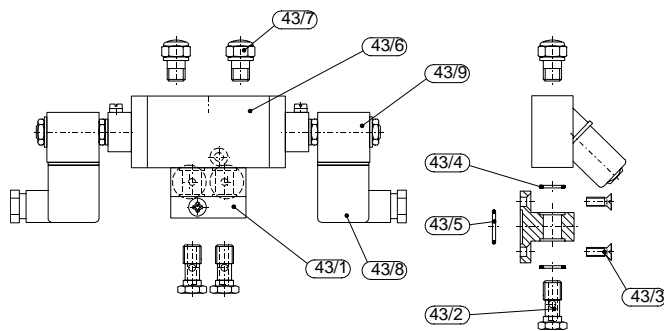

\*\* Specify voltage!  
 (e.g. N-7510-2-**220V 50Hz**)

**Position indicators 80°C (single + double) in various versions with adapter**

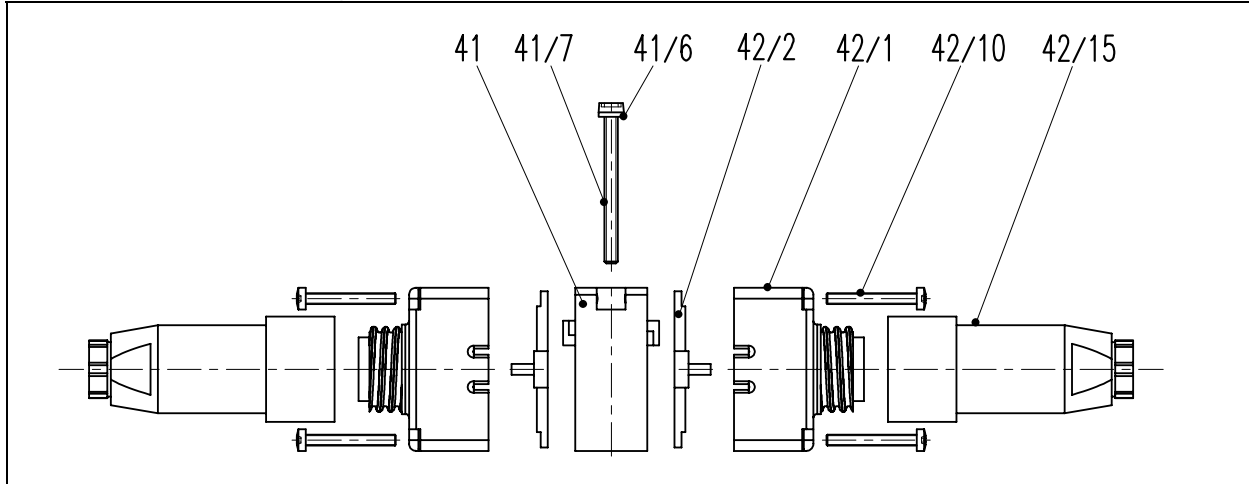

Item	Description	Version	Qty.		Part No.
			single	double	
41	Adapter complete		1	1	72228-R1 83923-R1
41/6	Spring ring		2	2	N-6162-404
41/7	Screw		2	2	N-6016-503
42	BS Mini position indicator	make contact switches double throw switches make contact radiation resistant double throw radiation resistant make contact switch with common plug for pos. indicator and solenoid	1 1 1 1 1	2 2 2 2 -	76664-R1 85399-R1 80074-R1 83953-R1 87997-R1
42/1	Position indicator	make contact switches double throw switches make contact radiation resistant double throw radiation resistant make contact switch with common plug for pos. indicator and solenoid	1 1 1 1 1	2 2 2 2 -	71852-R1 70606-R1 80075-R1 83954-R1 82560-R1
42/2	Slider		1	2	69846-01
42/10	Screw		4	8	N-6024-531
42/15	Socket		1	2	N-8504-002
	Cable socket, snaked		1	2	N-8504-005

**Position indicators 200°C (single + double) with adapter**

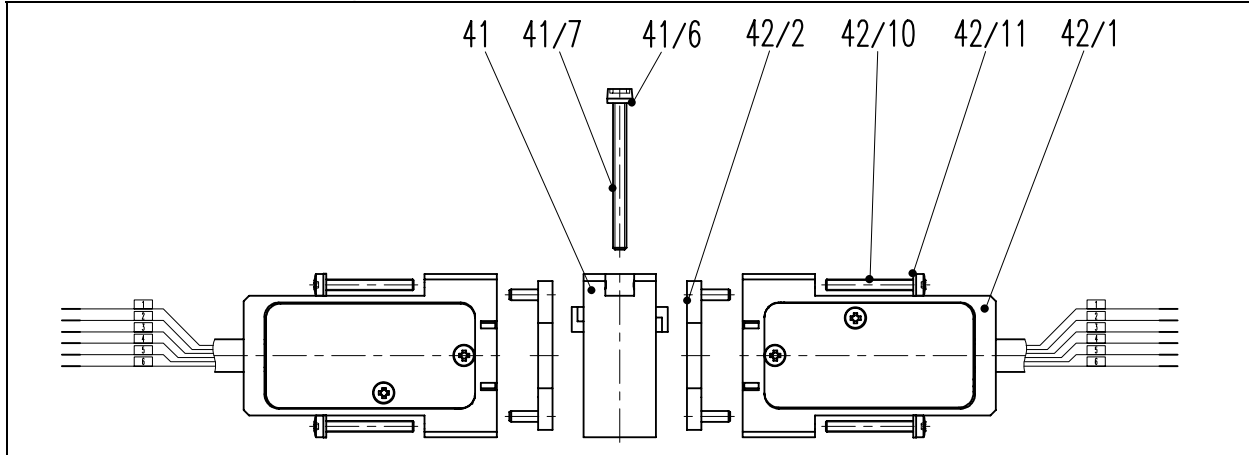

Item	Description	Version	Qty.		Part No.
			single	double	
41	Adapter complete		1	1	72228-R1 83923-R1
41/6	Spring ring		2	2	N-6162-404
41/7	Screw		2	2	N-6016-503
42	BS Mini position indicator	double throw switches	1	2	241823
42/1	Position indicator		1	2	241824
42/2	Slider		1	2	241825
42/10	Screw		4	8	N-6024-531
42/11	Spring ring		4	8	N-6160-406





## 8 Warranty

Each product sold by VAT Vakuumventile AG (VAT) is warranted to be free from the manufacturing defects that adversely affect the normal functioning thereof during the warranty period stated in VAT's «Terms of Sale» immediately following delivery thereof by VAT, provided that the same is properly operated under conditions of normal use and that regular, periodic maintenance and service is performed or replacements made, in accordance with the instructions provided by VAT. The foregoing warranty shall not apply to any product or component that has been repaired or altered by anyone other than an authorized VAT representative or that has been subject to improper installation or abuse, misuse, negligence or accident. VAT shall not be liable for any damage, loss, or expense, whether consequential, special, incidental, direct or otherwise, caused by, arising out of or connected with the manufacture, delivery (including any delay in or failure to deliver), packaging, storage or use of any product sold or delivered by VAT shall fail to conform to the foregoing warranty or to the description thereof contained herein, the purchaser thereof, as its exclusive remedy, shall upon prompt notice to VAT of any such defect or failure and upon the return of the product, part or component in question to VAT at its factory, with transportation charges prepaid, and upon VAT's inspection confirming the existence of any defect inconsistent with said warranty or any such failure, be entitled to have such defect or failure cured at VAT's factory and at no charge therefor, by replacement or repair of said product, as VAT may elect. VAT MAKES NO WARRANTY OR REPRESENTATION OF ANY KIND, EXPRESS OR IMPLIED, (INCLUDING NO WARRANTY OR MERCHANTABILITY), EXCEPT FOR THE FOREGOING WARRANTY AND THE WARRANTY THAT EACH PRODUCT SHALL CONFORM TO THE DESCRIPTION THEREOF CONTAINED HEREIN, and no warranty shall be implied by law.

Furthermore, the «Terms of sale» at the back of the price list are applicable.