

Pendulum control & isolation valve with RS232 interface

This manual is valid for the valve ordering number(s):

650 GG -	(1 sensor input)
650 GH -	(2 sensor inputs)
650 AG -	(1 sensor input / ±15V SPS)
650 AH -	(2 sensor inputs / ±15V SPS)
650 HG -	(1 sensor input / PFO)
650 HH -	(2 sensor inputs / PFO)
650 CG -	(1 sensor input / ±15V SPS / PFO)
650 CH -	(2 sensor inputs / ±15V SPS / PFO)
650 GV -	(1 sensor input / analog outputs)
650 GW -	(2 sensor inputs / analog outputs)
650 AV -	(1 sensor input / analog outputs / ±15V SPS)
650 AW -	(2 sensor inputs / analog outputs / ±15V SPS)
650 HV -	(1 sensor input / analog outputs / PFO)
650 HW -	(2 sensor inputs / analog outputs / PFO)
650 CV -	(1 sensor input / analog outputs / ±15V SPS / PFO)
650 CW -	(2 sensor inputs / analog outputs / ±15V SPS / PFO)

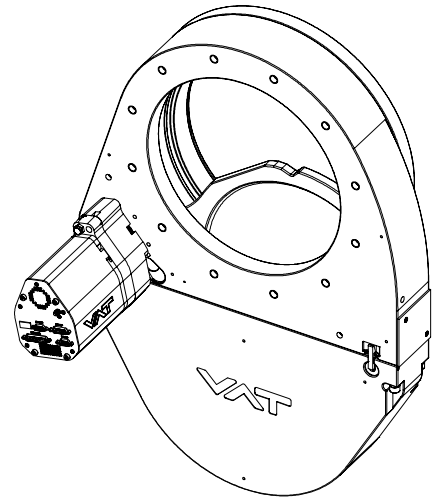



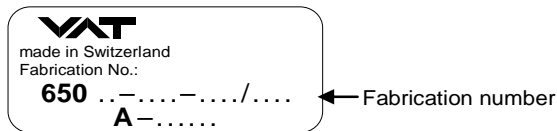

SPS = Sensor Power Supply PFO = Power Failure Option
 configured with firmware **650P.1D.00, 650P.1E.32, 650P.1E.42**

The fabrication number is indicated on each product as per the label below (or similar):



Explanation of symbols:

- | | | | |
|---|---|---|--|
|  | Read declaration carefully before you start any other action! |  | Keep body parts and objects away from the valve opening! |
|  | Attention! |  | Hot surfaces; do not touch! |
|  | Loaded springs and/or air cushions are potential hazards! |  | Wear gloves! |
|  | Disconnect electrical power and compressed air lines. Do not touch parts under voltage! | | |

 Read these «**Installation, Operating & Maintenance Instructions**» and the enclosed «**General Safety Instructions**» carefully before you start any other action!



Installation, Operating & Maintenance Instructions
Series 650, DN 320 – 400 (I.D. 12" - 16")

Imprint

Manufacturer VAT Vakuumventile AG, CH-9469 Haag, Switzerland

Website	Phone	Fax	Email
www.vatvalve.com	+41 81 771 61 61	+41 81 771 48 30	CH@vatvalve.com

Publisher VAT Vakuumventile AG, Control Valve Group PG5

Editor VAT Vakuumventile AG, Control Valve Group PG5

Print VAT Vakuumventile AG, CH-9469 Haag, Switzerland

Copyright © VAT Vakuumventile AG 2011

No part of these Instructions may be reproduced in any way (photocopies, microfilms or any other reproduction processes) nor may it be manipulated with electronic systems, duplicated or distributed without written permission from VAT. Offenders are liable to pay damages.

The original VAT firmware and updated state of the art versions of the VAT firmware are intended for use with VAT products. The VAT firmware contains a limited, time unlimited user license. The VAT firmware may not be used for purposes other than those intended nor is it permitted to make copies of the VAT firmware. In particular, it is strictly forbidden to give copies of the VAT firmware to other people.

The use of trade names, brand names, trademarks, etc. in these Instructions does not entitle third parties to consider these names to be unprotected and to use them freely. This is in accordance with the meaning of the laws and acts covering brand names and trademarks.

**Contents:**

1	Use of product	4
1.1	Technical data	4
2	Installation	7
2.1	Unpacking	7
2.2	Installation into the system	7
2.3	Tightening torque	9
2.3.1	Mounting with centering rings	9
2.3.2	Mounting with O-ring in grooves	9
2.4	Admissible forces	10
2.5	Requirements to sensor connection	10
2.6	Electrical connection	11
2.6.1	Sensor supply concepts	11
2.6.2	Power and sensor connection (+24 VDC sensors)	12
2.6.3	Power and sensor connection (± 15 VDC sensors) without optional SPS module	13
2.6.4	Power and sensor connection (± 15 VDC sensors) with optional SPS module	14
2.6.5	RS232 interface connection	15
2.6.6	Service port connection	15
3	Operation	16
3.1	Introduction	16
3.1.1	Local operation	16
3.1.2	Remote operation	17
3.1.3	Safety mode	17
3.2	Operation under increased temperature	18
3.3	Behavior during power up	18
3.4	Behavior in case of power failure	18
3.5	Display information	19
3.6	Setup procedure	21
3.6.1	Interface configuration	21
3.6.2	Valve and sensor configuration	22
3.6.3	ZERO	22
3.6.4	LEARN	23
3.7	Close valve	25
3.8	Open valve	25
3.9	Position control	25
3.10	Pressure control	26
3.10.1	Pressure control operation with 2 sensors	26
3.10.2	Tuning of control performance	26
3.11	RS232 interface	32
3.11.1	Schematics	32
3.11.2	Digital inputs	34
3.11.3	RS232 command syntax	35
3.11.4	RS232 control commands	35
3.11.5	RS232 inquiry commands	36
3.11.6	RS232 setup commands	41
3.11.7	RS232 error messages	46
4	Trouble shooting	47
5	Maintenance & repairs	49
5.1	Maintenance procedures	50
5.2	Option board	56
5.2.1	Durability of power fail battery	56
5.2.2	Retrofit / replacement procedure	57
6	Drawing	60
7	Spare parts and accessories	61
7.1	Accessories	61
7.2	Control unit	61
7.3	Valve unit	62
8	Warranty	63



1 Use of product

This product is a throttling pendulum valve with isolation functionality. It is intended to use for downstream pressure control applications.

Use product for clean and dry indoor vacuum applications under the conditions indicated in chapter «Technical data» only! Other applications are only allowed with the written permission of VAT.

1.1 Technical data

Control and actuating unit	
Power input ¹⁾ (α) [650 A / 650 G] [650 C / 650 H]	+ 24 VDC (±10%) [connector: POWER] 50 W max. (operation of valve with max. load) without PFO ⁴⁾ 60 W max. (operation of valve with max. load) with PFO ⁴⁾
Sensor power supply ²⁾ (β) [650 A / 650 C] Input Output	+ 24 VDC (±10%) / 36 W max. [connector: POWER] ± 15 VDC (±5%) / 1.0 A max. [connector: SENSOR]
Sensor power supply ²⁾ (β) [650 G / 650 H] Input Output	+ 24 VDC resp. ± 15 VDC [connector: POWER] same as input but: 2.0 A max. at ± 15 VDC [connector: SENSOR] 1.5 A max. at + 24 VDC

Calculation of complete power consumption:

$$P_{\text{tot}} = \alpha + \beta$$

whereas β depends on sensor supply concept and sensor power consumption.



Installation, Operating & Maintenance Instructions
Series 650, DN 320 – 400 (I.D. 12" - 16")

Control and actuating unit (continuation)			
Sensor input Signal input voltage Input resistance ADC resolution Sampling time	0 – 10 VDC (linear to pressure) [connector: SENSOR] 100kΩ 0.23 mV 10 ms		
Digital inputs ³⁾	± 24 VDC max. [connector: INTERFACE]		
Digital outputs ³⁾ Input voltage Input current Breaking capacity	70 VDC or 70 V peak max. 0.5 ADC or 0.5 A peak max. 10 W max. [connector: INTERFACE]		
Analog outputs ³⁾	0 - 10 VDC / 1mA max. [connector: INTERFACE]		
PFO ⁴⁾ battery pack [650 C / 650 H] Charging time Durability	2 minutes max. up to 10 years @ 25°C ambient; refer to «5.2.1 Durability of power fail battery» for details		
Compressed air supply	4 - 7 bar / 55 - 100 psi (above ATM)		
Ambient temperature	50 °C max. (<35°C recommended)		
Pressure control accuracy	0.1% of sensor full scale		
	DN 320 12" (65050 -)	DN 350 14" (65051 -)	DN 400 16" (65052 -)
Position resolution / position control capability	13'333 steps (full stroke)	13'422 steps (full stroke)	13'511 steps (full stroke)
Closing time throttling only	1.1 s (full stroke)	1.3 s (full stroke)	1.5 s (full stroke)
Opening time throttling only	1.1 s (full stroke)	1.3 s (full stroke)	1.5 s (full stroke)
Closing time throttling & isolation	5 s typ. (full stroke)	5 s typ. (full stroke)	5 s typ. (full stroke)
Opening time throttling & isolation	6 s typ. (full stroke)	6 s typ. (full stroke)	6 s typ. (full stroke)

- 1) Internal overcurrent protection by a PTC device.
- 2) Refer to chapter «2.6.1 Sensor supply concepts» for details.
- 3) Refer to chapter «3.11.1 Schematics» for details.
- 4) PFO = Power Failure Option. Refer to «3.4 Behavior in case of power failure» for details.



Valve unit			
Pressure range at 20°C			
- Aluminum (650 A)	1 x 10 ⁻⁸ mbar to 1.2 bar (abs)		
- Aluminum hard anodized (650 H)	1 x 10 ⁻⁶ mbar to 1.2 bar (abs)		
- Aluminum nickel coated (650 I)	1 x 10 ⁻⁸ mbar to 1.2 bar (abs)		
Leak rate to outside at 20°C			
- Aluminum (650 A)	1 x 10 ⁻⁹ mbar ls ⁻¹		
- Aluminum hard anodized (650 H)	1 x 10 ⁻⁵ mbar ls ⁻¹		
- Aluminum nickel coated (650 I)	1 x 10 ⁻⁹ mbar ls ⁻¹		
Leak rate valve seat at 20°C			
- Aluminum (650 A)	1 x 10 ⁻⁹ mbar ls ⁻¹		
- Aluminum hard anodized (650 H)	1 x 10 ⁻⁴ mbar ls ⁻¹		
- Aluminum nickel coated (650 I)	1 x 10 ⁻⁹ mbar ls ⁻¹		
Cycles until first service			
- Isolation cycles (open - closed - open)	200'000 (unheated and under clean conditions)		
- Throttling cycles (open - max. throttle - open)	1 Mio. (unheated and under clean conditions)		
Admissible operating temperature	10 ... 150°C		
Mounting position	Horizontal only (valve seat to face chamber is recommended)		
Wetted materials			
- Body (650 A)	Aluminum 3.2315 (AA6082)		
- Body (650 H)	Aluminum 3.2315 (AA6082) hard anodized		
- Body (650 I)	Aluminum 3.2315 (AA6082) nickel coated		
- Pendulum plate (650 A)	Aluminum 3.2315 (AA6082)		
- Pendulum plate (650 H)	Aluminum 3.2315 (AA6082) hard anodized		
- Pendulum plate (650 I)	Aluminum 3.2315 (AA6082) nickel coated		
- Sealing ring (650 A)	Aluminum 3.2315 (AA6082), 1.4306 (304L)		
- Sealing ring (650 H)	Aluminum 3.2315 (AA6082) hard anodized, 1.4306 (304L)		
- Sealing ring (650 I)	Aluminum 3.2315 (AA6082) nickel coated, 1.4306 (304L)		
- Other parts	Stainless steel 1.4435 (316L), 1.4404 (316L), 1.4122, 1.4310 (301), 1.4303 (304), 1.4571, A2 (304)		
- Seals	Viton® (standard). Other materials available. Seal materials are declared on dimensional drawing of specific valve ordering number.		
	DN 320 12" (65050 -)	DN 350 14" (65051 -)	DN 400 16" (65052 -)
Max. differential pressure on plate during isolation	1200 mbar	1200 mbar	1200 mbar
Max. differential pressure on plate during opening and throttling	5 mbar	5 mbar	5 mbar
Min. controllable conductance (N ₂ molecular flow)	22 ls ⁻¹	25 ls ⁻¹	30 ls ⁻¹
Dimensions	Refer to dimensional drawing of specific valve ordering number (available on request)		

2 Installation

2.1 Unpacking

As this valve is a heavy component you should lift it with adequate equipment to prevent any injury to humans.



The valve is equipped with attachment points (tapped holes). Add eyebolts to these attachment points for lifting. The attachment points are indicated on the dimensional drawing of the specific valve part number (available on request).

Never lay the valve down with control and actuating unit downwards as it may be damaged.

2.2 Installation into the system



Fingers and objects must be kept out of the valve opening and away from moving parts. The valve plate may start to move just after power is supplied.



Do not connect or disconnect sensor cable when device is under power.



Do not disconnect air supply when device is under power.

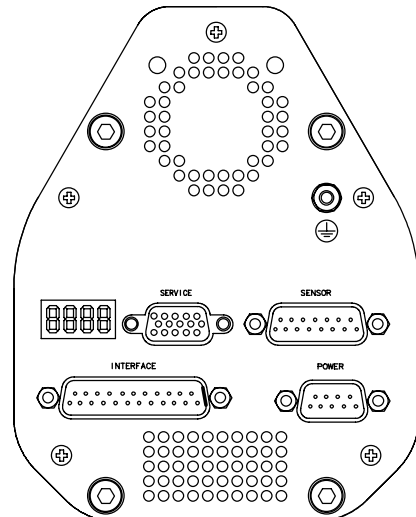
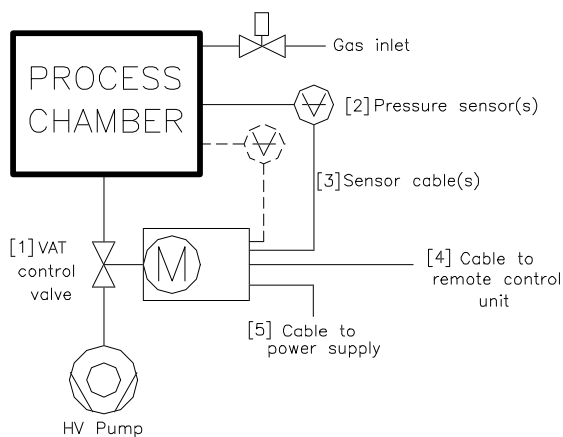



1. Install valve [1] into the vacuum system. Valve seat side should face process chamber. The valve seat side is indicated by the symbol "∇" on the valve flange.
Caution: Do not tighten the flange screws stronger than indicated under «2.3 Tightening torque».
Caution: Do not admit higher forces to the valve than indicated under «2.4 Admissible forces».
Note: Make sure that enough space is kept free to do preventive maintenance work. The required space is indicated on the dimensional drawing.
2. Connect compressed air supply to connection labeled 'IN' located at actuator.
Connect compressed air return line connection labeled 'OUT' located at actuator.
Compressed air pressure (above ATM) must be in the range of: **4 - 7 bar / 55 - 100 psi**. Use only clean, dry or slightly oiled air. IN / OUT connections are 1/8" ISO/NPT internal threads.
3. Install sensor(s) [2] according to the recommendations of the sensor manufacturer and directives given under «2.5 Requirements to sensor connection».
4. Connect sensor cable [3] to sensor(s) and then to valve (connector: SENSOR). Refer to chapter «2.6 Electrical connection» for correct wiring.
Note: Input for second sensor is available on 650 **H** - and 650 **W** - versions only.
5. Connect valve to remote control unit [4] (connector: INTERFACE). Refer to «3.11.1 Schematics» for correct wiring.
6. Connect power supply [5] to valve (connector: POWER). Refer to chapter «2.6 Electrical connection» for correct wiring.
Note: To provide power to the valve motor pins 4 and 8 must be bridged, otherwise motor interlock is active and the valve enters the safety mode and is not operative. Refer also to «3.1.3 Safety mode».
7. This valve has a double sealed rotary feedthrough with intermediate pumping port for the actuator shaft. This port (1/8" ISO/NPT) may optionally be connected to the vacuum line.
8. This valve may optionally be equipped with a heating device. Connect VAT heating device according to manual of respective heating device.
9. Perform «3.6 Setup procedure» to prepare valve for operation.
Note: Without performing the setup procedure the valve will not be able to do pressure control.

2.3 Tightening torque

Tighten mounting screws of the flanges uniformly in crosswise order. Observe the maximum torque levels in the following table. Higher tightening torques deforms the valve body and may lead to malfunction of the valve.

2.3.1 Mounting with centering rings

Valve size	ISO-F	ISO-F
	max. tightening torque (Nm)	max. tightening torque (lbs . ft)
DN320 / 12" (65050 -)	17 – 20	13 – 15
DN350 / 14" (65051 -)	–	–
DN400 / 16" (65052 -)	17 – 20	13 – 15
	hole depth (mm)	hole depth (inch)
DN320 / 12" (65050 -)	18	0.71
DN350 / 14" (65051 -)	–	–
DN400 / 16" (65052 -)	20	0.79

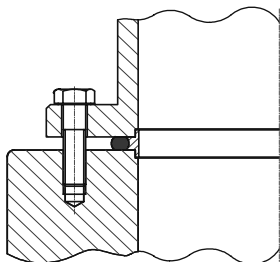

Caution: Make sure that screws are not too long otherwise the valve body may be damaged.

Note: Use slightly lubricated screws.

Refer to «7 Spare parts and accessories» for centering rings ordering numbers.

2.3.2 Mounting with O-ring in grooves

Valve size	ISO-F	JIS	ASA-LP	ISO-F	JIS	ASA-LP
	max. tightening torque (Nm)			max. tightening torque (lbs . ft)		
DN320 / 12" (65050 -)	65-70	65-70	80-90	48-52	48-52	59-67
DN350 / 14" (65051 -)	–	65-70	–	–	48-52	–
DN400 / 16" (65052 -)	65-70	115-120	230-240	48-52	85-89	170-178
	hole depth (mm)			hole depth (inch)		
DN320 / 12" (65050 -)	18	18	18	0.71	0.71	0.71
DN350 / 14" (65051 -)	–	18	–	–	0.71	–
DN400 / 16" (65052 -)	20	25	25	0.79	0.98	1.0

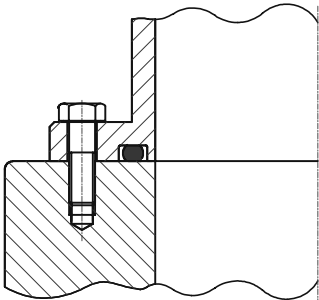

Caution: Make sure that screws are not too long otherwise the valve body may be damaged.

Note: These torques are valid if depth of the mounting screws is min. 1 x thread diameter. Make sure that screws in use are capable to withstand applied torques. Lubricate screws slightly.

2.4 Admissible forces

Forces from evacuating the system, from the weight of other components, and from baking can lead to deformation and malfunctioning of the valve. Stress has to be relieved by suitable means, e.g. bellows sections.

Valve size (65050 -)	Axial tensile or compressive force «F _A »		Bending moment «M»	
	N	lb.	Nm	lbf.
DN320 / 12" (65050 -)	3000	660	120	90
DN350 / 14" (65051 -)	3500	770	140	105
DN400 / 16" (65052 -)	4000	880	160	120

For a combination of both forces (F_A and M) the values are invalid.
Verify that the depth of the mounting screws is min. 1 x thread diameter.
Please contact VAT for more information.

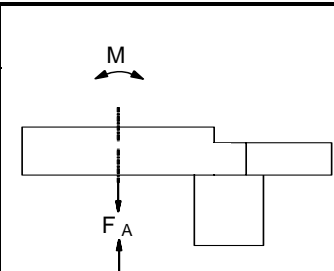

2.5 Requirements to sensor connection

To achieve fast and accurate pressure control a fast sensor response is required.

Sensor response time: < 50ms

The sensor is normally connected to the chamber by a pipe. To maintain that the response time is not degraded by this connection it needs to meet the following requirements:

Inner diameter of connection pipe: **> = 10 mm**

Length of connection pipe: **< = 300 mm**

These conductance guidelines must include all valves and limiting orifices that may also be present.

Make also sure that there is no obstruction in front of sensor connection port inside the chamber.

The sensor should also be mounted free of mechanical shock and vibration.

Dynamic stray magnetic fields may introduce noise to sensor output and should be avoided or shielded.

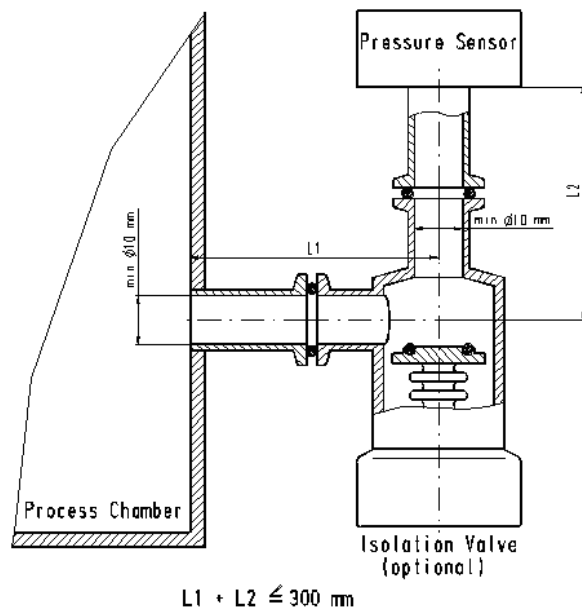



2.6 Electrical connection

2.6.1 Sensor supply concepts

This valve offers 3 alternative concepts to supply the sensor(s) with power. This depends on the sensor type and valve version that is used. This valve is available with an optional sensor power supply module (SPS) that converts ± 15 VDC from the 24 VDC.

Valve versions:

- 650 **G** and 650 **H** SPS module not included
- 650 **A** and 650 **C** SPS module included

Note: The SPS module can be retrofitted. Refer to chapter «5.2.2 Retrofit / replacement procedure» for instruction.

Concepts:

- External + 24 VDC supplied to POWER connector is feed through to SENSOR connector to supply 24 VDC sensors. Refer to chapter «2.6.2 Power and sensor connection (+24 VDC sensors)» for schematic and correct wiring.
- External ± 15 VDC supplied to POWER connector is feed through to SENSOR connector to supply ± 15 VDC sensors. Refer to chapter «2.6.3 Power and sensor connection (± 15 VDC sensors) without optional SPS module» for schematic and correct wiring.
- External + 24 VDC supplied to POWER connector is converted into ± 15 VDC by the valve internal SPS and supplied to SENSOR connector to supply ± 15 VDC sensors. Refer to chapter «2.6.4 Power and sensor connection (± 15 VDC sensors) with optional SPS module» for schematic and correct wiring.

2.6.2 Power and sensor connection (+24 VDC sensors)

[650 G / 650 H versions recommended]

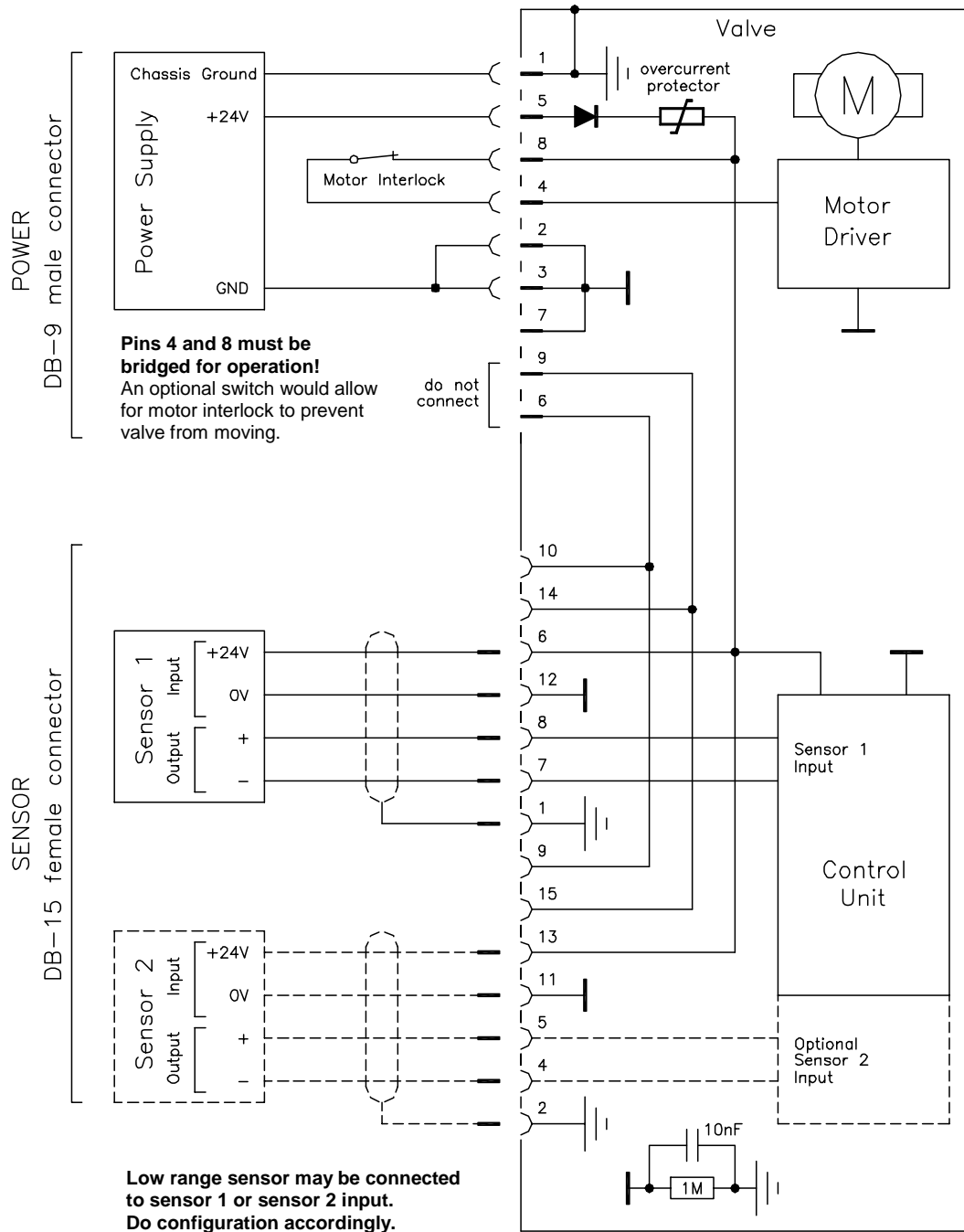

2.6.3 Power and sensor connection (± 15 VDC sensors) without optional SPS module
 [650 G / 650 H versions only]

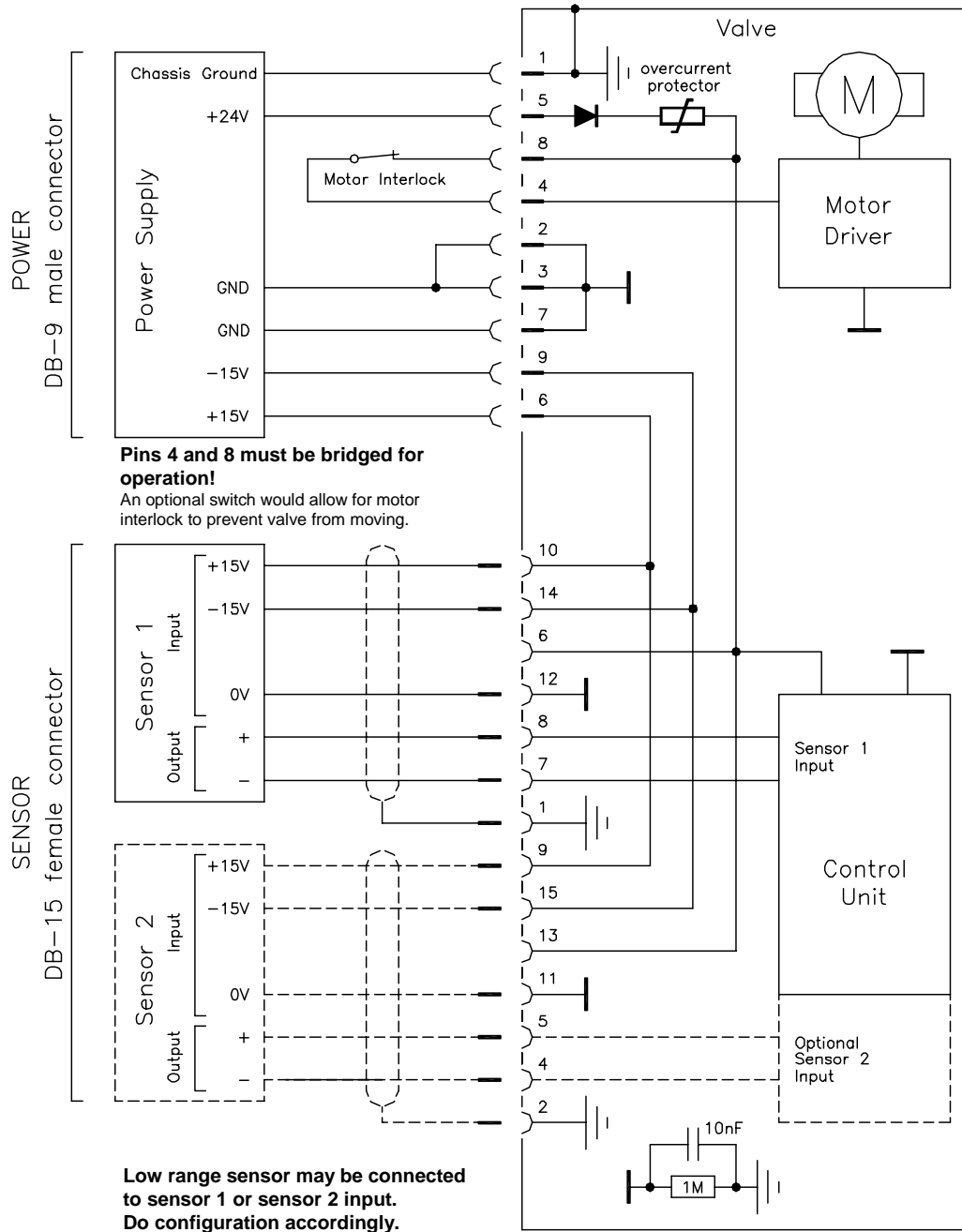

Note: Use shielded sensor cable(s). Keep cable as short as possible, but locate it away from noise sources.

2.6.4 Power and sensor connection (± 15 VDC sensors) with optional SPS module
 [650 A / 650 C versions only]

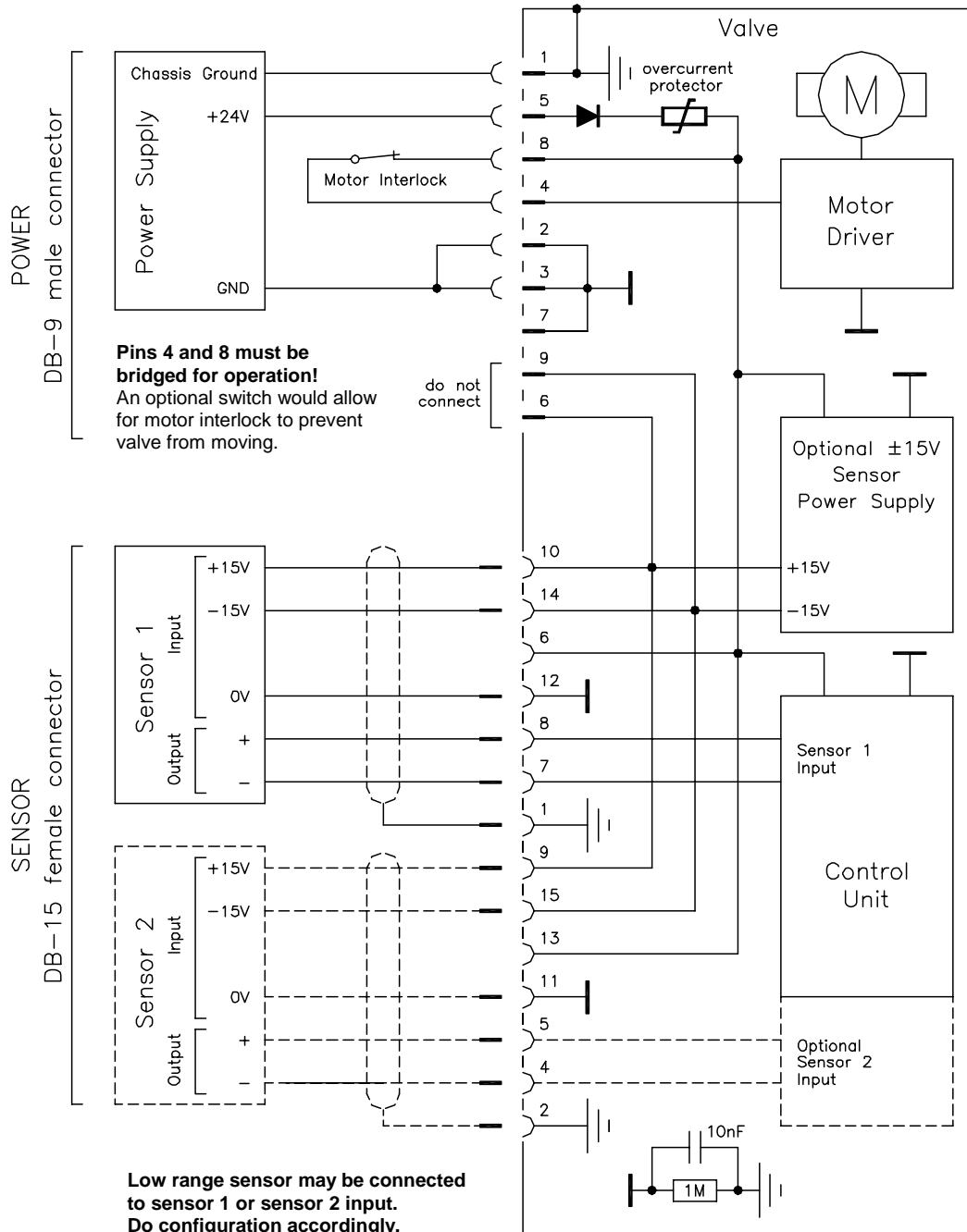

Note: Use shielded sensor cable(s). Keep cable as short as possible, but locate it away from noise sources.



2.6.5 RS232 interface connection

Refer to «3.11.1 Schematics» for wiring information.

2.6.6 Service port connection

The service port (connector: SERVICE) allows to connect the valve to a RS232 port of a computer.

This requires a service cable and a software from VAT. You can either use our freeware 'Control View' or purchase our 'Control Performance Analyzer'.

The service port is not galvanic isolated. Therefore we recommend using this only for setup, testing and maintenance and not for permanent control.

Refer also to «3.1.1 Local operation» for details and to «7 Spare parts and accessories» for ordering numbers of service cable and software.



3 Operation

3.1 Introduction

This valve is designed for downstream pressure control in vacuum chambers. It can be employed in a pressure control mode or a position control mode.

In both cases local or remote operation is possible.

3.1.1 Local operation

Local operation means that the valve is operated via the service port by means of a computer. A service cable and a software from VAT is required. You can either download our freeware 'Control View' from www.vatvalve.com or purchase our 'Control Performance Analyzer'.

These softwares are beneficial especially for setup, testing and maintenance.

How to start: Connect service cable, start software and push button 'LOCAL' to enable for operation. Then enter menu Setup/Sensor and do sensor configuration according to your application to make sure that you get the correct pressure displayed.

'Control view' supports:

- parameter setup
- manual control
- numeric monitoring
- basic diagnostic

'Control Performance Analyzer' supports:

- parameter setup
- manual control
- sequence control
- numeric and graphical monitoring
- data recording
- data analysis
- advanced diagnostic

Note: When communication to service port is interrupted the valve will change to remote operation. So when service cable will be disconnected or software will be shut down, the valve returns automatically to remote operation.

Refer to «7 Spare parts and accessories» for ordering numbers of service cable and software.



3.1.2 Remote operation

This product is equipped with a RS232 interface to allow for remote operation. See section «3.11 RS232 interface» for details. 'Control View' or 'Control Performance Analyzer' software may be used for monitoring during remote control.

Note: In case 'Control View' or 'Control Performance Analyzer' is connected to valve make sure 'REMOTE' button is pushed to enable for remote operation.

3.1.3 Safety mode

By means of an external switch (see connection diagrams «2.6.1 to 2.6.4») the motor power supply can be interrupted. In this case the valve enters the 'safety mode'. This motor interlock prevents the valve from moving (e.g. maintenance work). Data reading from the control unit remains possible.

When motor interlock is active during power up the valve directly enters the 'safety mode' and is not able to synchronize. Display shows 'D C' or 'D999'. In this case synchronization cycle will be done when motor interlock is deactivated. Then Display shows 'INIT' for a moment followed by 'SYNC'.

When 'safety mode' is entered from operation, the valve plate stops at current position. Once motor interlock is deactivated the unit starts a power up cycle according «3.3 Behavior during power up».



3.2 Operation under increased temperature

This valve may be operated in the temperature range mentioned in chapter «1.1 Technical data».

3.3 Behavior during power up

Valve position before power up:	Reaction of valve:	
	Valve power up configuration = closed (default)	Valve power up configuration = open
Closed (isolated)	Valve remains closed. Display shows alternately 'C C' and 'INIT'. Synchronization will be done when first movement command is received.	Valve runs to max. throttle position to detect the limit stops to synchronize. Display shows configuration of product resp. 'SYNC' until synchronization is done. Valve position after power up is open.
All other than closed (not isolated)	Valve runs to max. throttle position to detect limit stop for synchronization. Display shows configuration of product resp. 'SYNC' until synchronization is done. Valve position after power up is closed	Valve position after power up is open

Refer also to chapter «3.5 Display information».

3.4 Behavior in case of power failure

Valve position before power failure:	Reaction of valve:	
	Without Power Failure Option (PFO) 650 G 650 A	With Power Failure Option (PFO) 650 H 650 C
Closed (isolated)	Valve remains closed.	Valve remains closed. Display indicates F
Valve open or in any intermediate position	Sealing ring moves down and blocks the pendulum plate at the current position.	Valve will close or open depending on valve configuration *). Display indicates F

*) Provided that battery pack of the VAT controller is charged. Charging time after power up is 2 minutes .

All parameters are stored in a power fail save memory.

3.5 Display information

There is a 4 digit display located on the panel. It displays configuration, status and position information. For details see table on next page.

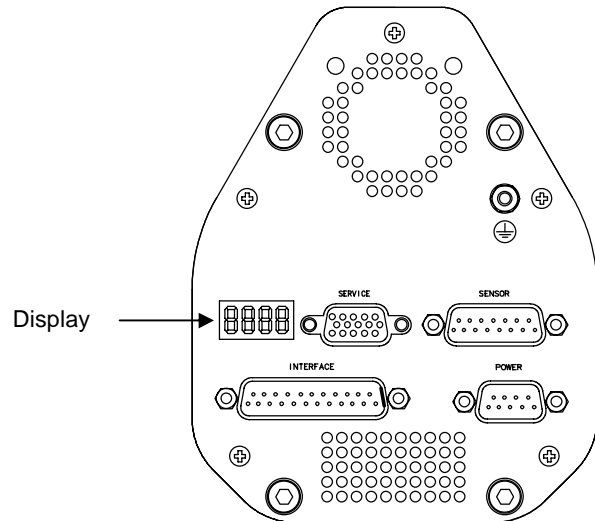

Power up:

Description	Digit 1	Digit 2	Digit 3	Digit 4
At first all dots are illuminated then configuration is displayed:	1	D	0	0
<ul style="list-style-type: none"> Firmware version [e.g. 1D00] (1st information for about 2s) Controller configuration (2nd information for about 2s) 		<p>2 = RS232 interface</p> <p>3 = RS232 interface with analog outputs</p>	<p>0 = basic</p> <p>1 = with SPS¹⁾</p> <p>2 = with PFO²⁾</p> <p>3 = with SPS¹⁾ and PFO²⁾</p>	<p>1 = 1 sensor version</p> <p>2 = 2 sensor version</p>
SYNC indicates that power up synchronization is running.				
In case D C or D999 is displayed, motor interlock is active. Refer to «3.1.3 Safety mode» for details.				
If valve is closed (isolated) display shows alternately C C and INIT . Synchronization will be done when first movement command is received.				
	S	Y	N	C

1) SPS = optional ±15 VDC Sensor Power Supply module

2) PFO = Power Failure Option



Operation:

Description / Mode	Digit 1	Digit 2	Digit 3	Digit 4
PRESSURE CONTROL mode	P	0 . . . 100 = valve position (% , 0 = closed / 100 = open)		
POSITION CONTROL mode	V			
Valve closed	C			
Valve open	O			
Closed / open interlock (Valve closed / open by digital input)	I			
HOLD (position frozen) activated	H			
ZERO running	Z			
LEARN running	L			
Safety mode established. Refer to «3.1.3 Safety mode» for details.	D			
Service request ¹⁾				
Power failure	F			

Note: Rx/D / Tx/D activity of RS232 communication is displayed by 2 blinking dots in digit 2. The lower dot indicates Rx/D activity where the upper dot indicates Tx/D activity. The indication is not real time.
¹⁾ SR is blinking alternatively with the actual mode display (e.g. C ↔ SR)

Errors:

Description	Digit 1	Digit 2	Digit 3	Digit 4
Compressed air failure (< 4 bar / 55 psi)	A	I	R	f
Compressed air on exhaust	A	I	R	x
Fatal error occurred	E	Error code. Refer to «4 Trouble shooting» for details		

3.6 Setup procedure



To enable this valve for **pressure control** setup **steps 1 to 5 must be performed**.
 In case position control is required only it's sufficient to perform steps 1 to 3.

Setup step	Description
1	Power up Turn on external + 24VDC power supply (and external ± 15 VDC for sensor power supply if required). Refer to chapter «3.3 Behavior during power up» for details.
2	Interface configuration RS232 parameters and digital inputs for valve must be configured. Refer to chapter «3.6.1 Interface configuration» for details.
3	Valve and sensor configuration Basic configurations of the valve must be adapted according to application needs. Refer to chapter «3.6.2 Valve and sensor configuration» for details.
4	ZERO Compensation of the sensor offset voltage. Refer to chapter «3.6.3 ZERO» for details.
5	LEARN Determination of the vacuum system characteristic to accommodate the PID controller. Refer to chapter «3.6.4 LEARN» for details. Note: Without LEARN the valve is not able to run pressure control

3.6.1 Interface configuration

Interface configuration must be adapted according to application needs.

- RS232 baudrate, parity, data length and number of stop bits for valve must be selected.
- Functionality of digital interlock inputs CLOSE VALVE and OPEN VALVE. These may be configured as 'not inverted', 'inverted' or 'disabled'. Default is 'not inverted'. Refer also to «3.11.2 Digital inputs».
- Pressure and position range for RS232 communication must be selected. Default for pressure is 0 - 1'000'000. Default for position is 0 - 100'000.

Local operation: (‘Control View’ resp. ‘Control Performance Analyzer’)	Remote operation: (Refer to chapter «3.11.6 RS232 setup commands» for details)
Do configuration in menu ‘Setup / Interface’.	1. Send INTERFACE CONFIGURATION 2. Send RANGE CONFIGURATION



3.6.2 Valve and sensor configuration

Basic valve configuration must be adapted according to application needs.

- Definition of valve plate position (CLOSED or OPEN) after power up sequence. Default is closed.
- Definition of valve plate position (CLOSED or OPEN) in case of a power failure. Default is closed. Only for versions that have Power Fail Option equipped [650 **C** or 650 **H**].
- ZERO function. This may be 'disabled' or 'enabled'. Default is 'enabled'. Refer also to «3.6.3 ZERO».
- Sensor configuration for 2 sensor versions [650 **H** and 650 **W**]. Refer also to «3.10.1 Pressure control operation with 2 sensors».

Local operation: (‘Control View’ resp. ‘Control Performance Analyzer’)	Remote operation: (Refer to chapter «3.11.6 RS232 setup commands» for details)
1. Do power up configuration in menu ‘Setup / Valve’.	1. Send VALVE CONFIGURATION
2. Do power fail configuration in menu ‘Setup / Valve’.	
3. Enable or disable ZERO function in menu ‘Setup / Sensor’.	2. Send SENSOR CONFIGURATION
4. Do 2 sensor configuration in menu ‘Setup / Sensor’.	

3.6.3 ZERO

ZERO allows for the compensation of the sensor offset voltage.

When ZERO is performed the current value at the sensor input is equated to pressure zero. In case of a 2 sensor system both sensor inputs will be adjusted. A max. offset voltage of +/-1.4V can be compensated. The offset value can be read via local and remote operation.

Local operation: (‘Control View’ resp. ‘Control Performance Analyzer’)	Remote operation: (Refer to chapter «3.11.4 RS232 control commands» resp. «3.11.6 RS232 setup commands» for details)
Go to menu ‘Zero / ZERO’ and follow instructions.	1. Send OPEN VALVE
	2. Wait until process chamber is evacuated and sensor signal is not shifting anymore.
	3. Send ZERO

Note: Do not perform ZERO as long as pressure gauge voltage is shifting otherwise incorrect pressure reading is the result. Refer to manual of sensor manufacturer for warm up time.

Note: Do not perform ZERO, if the base pressure of your vacuum system is higher than 1‰ of sensor full scale. We recommend disabling ZERO function in this case; refer to «3.6.2 Valve and sensor configuration» of the setup procedure. Otherwise incorrect pressure reading is the result. Alternatively pressure alignment function may be used in such a case. Refer to «3.11.6 RS232 setup commands, PRESSURE ALIGNMENT» for details.



3.6.4 LEARN

LEARN adapts the PID controller of the valve to the vacuum system and its operating conditions. LEARN must be executed only once during system setup.

The LEARN routine determines the characteristic of the vacuum system. Based on this, the PID controller is able to run fast and accurate pressure control cycles.

This characteristic depends on various parameters such as chamber volume, conductance and flow regime. Therefore it must be performed with a specific gas flow according to instruction below.

The result of LEARN is a pressure versus valve position data table. This table is used to adapt the PID parameters. The data table is stored in the device memory which is power fail save. The data table can be up-/downloaded via 'Control Performance Analyzer' software or remote interface. Due to encoding the data may not be interpreted directly.

By an OPEN VALVE, CLOSE VALVE, POSITION CONTROL or PRESSURE CONTROL command the routine may be interrupted.

Local operation: (‘Control View’ resp. ‘Control Performance Analyzer’)	Remote operation: (Refer to chapter «3.11.4 RS232 control commands» resp. «3.11.6 RS232 setup commands» for details)
Go to ‘Learn / LEARN’ menu and follow instructions. Note: Gasflow calculation according to recommendation below is done automatically based on inputs.	<ol style="list-style-type: none">1. Send OPEN VALVE2. Set specific gas flow according to calculation below and wait until flow is stable. LEARN does not need to be performed with the process gas. Instead N₂ or Ar may be used.3. Send LEARN (with pressure limit set to full scale)

Note: Sensor signal must not shift during LEARN. Wait until sensor signal is stable before LEARN is performed.

Note: Learn may take several minutes. Do not interrupt the routine as **a single full run is required to ensure fast and accurate pressure control**. The PID controller covers 5% to 5000% of the gas flow which was used for learn.



Gasflow calculation for LEARN:



Do not apply a different gasflow for learn than determined below. Otherwise pressure control performance may be insufficient.

Choose the applicable formula depending on units you are familiar with.

$$q_L = \frac{p_{SFS} \cdot C_{min}}{2000}$$

q_L gasflow for learn [**Pa m³/s**]
 p_{SFS} sensor full scale pressure [**Pa**]
 C_{min} min. controllable conductance of valve [l/s]
(refer to «1.1 Technical data»)

$$q_L = \frac{p_{SFS} \cdot C_{min}}{2}$$

q_L gasflow for learn [**mbar l/s**]
 p_{SFS} sensor full scale pressure [**mbar**]
 C_{min} min. controllable conductance of valve [l/s]
(refer to «1.1 Technical data»)

$$q_L = 39.4 \cdot p_{SFS} \cdot C_{min}$$

q_L gasflow for learn [**sccm**]
 p_{SFS} sensor full scale pressure [**Torr**]
 C_{min} min. controllable conductance of valve [l/s]
(refer to «1.1 Technical data»)



3.7 Close valve

Local operation: (‘Control View’ resp. ‘Control Performance Analyzer’)	Remote operation: (Refer to chapter «3.11.4 RS232 control commands» for details)
Push CLOSE button	Send CLOSE VALVE

3.8 Open valve

Local operation: (‘Control View’ resp. ‘Control Performance Analyzer’)	Remote operation: (Refer to chapter «3.11.4 RS232 control commands» for details)
Push OPEN button	Send OPEN VALVE

3.9 Position control

The valve position is directly controlled according to the position setpoint.

Local operation: (‘Control View’ resp. ‘Control Performance Analyzer’)	Remote operation: (Refer to chapter «3.11.4 RS232 control commands» for details)
Select or enter position setpoint	Send POSITION CONTROL

3.10 Pressure control



To **prepare valve for PRESSURE CONTROL** perform complete «**3.6 Setup procedure**».

The valve has parameters that may be modified to tune **pressure control performance**. Refer to «**3.10.2 Tuning of control performance**».

The included PID controller controls the chamber pressure according to the pressure setpoint by means of the valve position. The PID controller works with an adaptive algorithm to achieve best results under altering conditions (gasflow, gas type).

Local operation: ('Control View' resp. 'Control Performance Analyzer')	Remote operation: (Refer to chapter «3.11.4 RS232 control commands» for details)
Select or enter pressure setpoint	Send PRESSURE CONTROL

3.10.1 Pressure control operation with 2 sensors

[applicable with 650 **H** - and 650 **W** - versions only]

If 2 sensor operation is enabled, changeover between the sensors is done automatically during pressure control. For configuration refer to chapter «3.6 Setup procedure». We recommend a ratio of 10:1 between the pressure gauges. Max. ratio is 100:1. High range respectively low range pressure gauge may be either connected to sensor 1 or sensor 2 input. It's required to do correct sensor configuration.

Between 90 and 100% of the low range sensor full scale, the low range sensor is phased out while high range sensor is phased in during pressure rise. During pressure decrease the high range sensor is phased out while low range sensor is phased in. This maintains a functional response behavior in case of small calibration errors between the two sensors. The PRESSURE output in this range is a blend between both sensors.

For monitoring purpose each sensor signal may be read out individually. Refer to «3.11.5 RS232 inquiry commands SENSOR 1 READING and SENSOR 2 READING»

Note: Make sure that both sensors are calibrated.

Note: Do not close optional gauge isolation valves during the transition phase between the sensors.

3.10.2 Tuning of control performance

Normally the default settings will result in good pressure control performance. For some applications tuning may be required to improve performance.

The tuning procedures for each parameter (grey boxes) and its default values are described separately below. Strictly keep the procedure order.

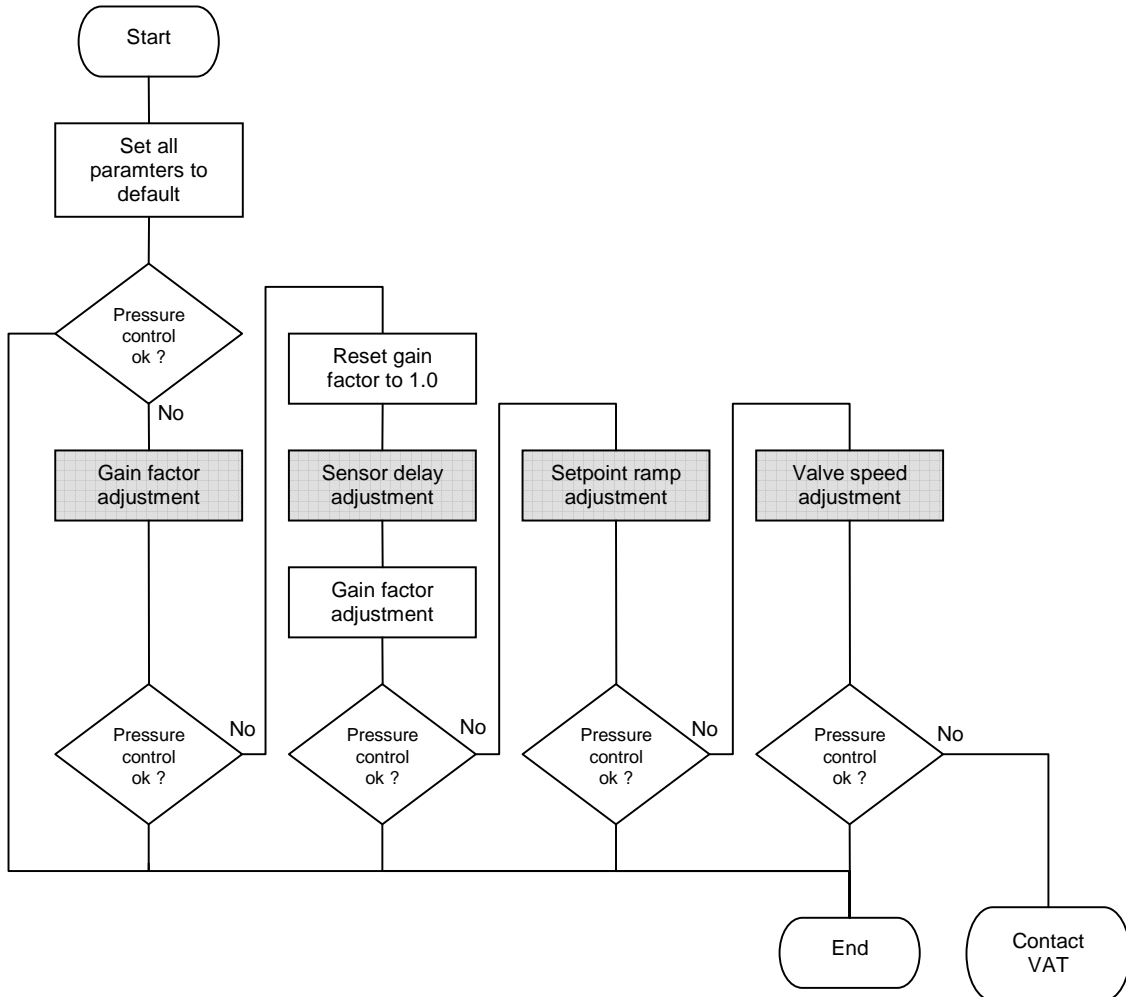

Required information for support:

- Go to 'Tools / Create Diagnostic File' in 'Control View' resp. 'Control Performance Analyzer' and save file
- Pressure / flow / gas conditions to be controlled
- Chamber volume
- Pumping speed (l/s) and pump type (e.g. turbo pump)
- System description
- Problem description

Send diagnostic file with and all required information to tuning-support@vat.ch



3.10.2.1 Gain factor adjustment

The gain factor effects:

- **Stability**
- **Response time**

Default value is 1.00. Adjustment range is from 0.0001 to 7.5.

Higher gain results in: faster response higher over- / undershoot of pressure
Lower gain results in: slower response lower over- / undershoot of pressure

Adjustment procedure:

1. Start with gain factor 1.0
2. Open valve.
3. Control a typical pressure / flow situation.
4. Repeat from step 2 with lower (higher) gain factors until optimal pressure response is achieved and stability is ok.

Note: Normally adjustments down to gain factors of 0.42 should lead to good results. Otherwise you may need to improve sensor connection. Refer to «2.5 Requirements to sensor connection».

Local operation: (‘Control View’ resp. ‘Control Performance Analyzer’)	Remote operation: (Refer to chapter «3.11.6 RS232 setup commands» for details)
Go to ‘Setup / Controller’ menu. Select gain factor.	Send PID CONTROLLER CONFIGURATION



3.10.2.2 Sensor delay adjustment

Sensor delay adjustment effects:

- **Stability**

Default value is 0. Adjustment range is from 0 to 1.0s.

Pipes and orifices for sensor attachment delay response time and so badly impact pressure control stability. By adapting this parameter to the approximate delay time stability problems can be reduced. But control response time will be slowed down by this measure.

Note: Whenever possible sensors should be attached to the chamber according to «2.5 Requirements to sensor connection». This is the most effective measure against stability issues. If your gauge attachment fulfills these criteria do not use this parameter.

Adjustment procedure:

1. Start with gain factor 1.0 and sensor delay 0s.
2. Open valve.
3. Control a typical pressure / flow situation.
4. Repeat from step 2 with higher sensor delays until best possible stability is achieved.
5. Adjustment gain factor again. Refer to «3.10.2.1 Gain factor adjustment».

Local operation: (‘Control View’ resp. ‘Control Performance Analyzer’)	Remote operation: (Refer to chapter «3.11.6 RS232 setup commands» for details)
Go to ‘Setup / Controller’ menu. Select sensor delay.	Send PID CONTROLLER CONFIGURATION

3.10.2.3 Setpoint ramp adjustment

Setpoint ramp effects:

- **Undershoot of pressure**
- **Response time**

Default value is 1.0 s. Adjustment range is from 0 to 10 s.

This parameter defines the time that is used to decrease / raise pressure between 2 setpoints. Especially in pressure decrease situations at low flows pressure response can be improved much by adapting setpoint ramp time.

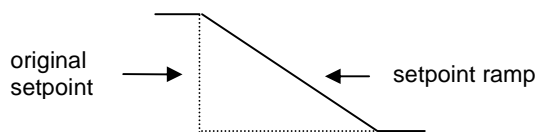

Adjustment procedure:

1. Start with optimal gain factor and sensor delay time according to preceding tuning steps.
2. Control a typical pressure / flow situation.
3. Control a lower pressure.
4. Repeat from step 2 with longer setpoint ramps until best response is achieved.
5. Verify pressure control response for a setpoint raise situation.

Note: In case a long ramp time is required to get optimal performance for pressure decrease situations it may be of advantage to apply different settings for decrease / raise control situations.

Local operation: ('Control View' resp. 'Control Performance Analyzer')	Remote operation: (Refer to chapter «3.11.6 RS232 setup commands» for details)
Go to 'Setup / Controller' menu. Select setpoint ramp.	Send PID CONTROLLER CONFIGURATION



3.10.2.4 Valve speed adjustment

Valve speed effects:

- **Response time**

Default value is 1000. Adjustment range is from 1 to 1000.

This parameter effects valve plate actuating speed.

Speed adjustment is effective for PRESSURE CONTROL and POSITION CONTROL.

Note: Normally best pressure control response is achieved with max. valve speed. In particular applications it may be of advantage to have a slower valve response.

Note: OPEN and CLOSE are always done with max. speed.

Adjustment procedure:

1. Use optimal gain factor, sensor delay time and setpoint ramp according to preceding tuning steps.
2. Open valve.
3. Control a typical pressure / flow situation.
4. Repeat from step 2 with slower valve speed until required response is achieved.

Local operation: (‘Control View’ resp. ‘Control Performance Analyzer’)	Remote operation: (Refer to chapter «3.11.6 RS232 setup commands» for details)
Go to ‘Setup / Controller’ menu. Select valve speed.	Send VALVE SPEED

3.11 RS232 interface

3.11.1 Schematics

This interface allows for remote operation by means of a command set based on the RS232 protocol. In addition there are 2 digital inputs and 2 digital outputs. Digital inputs may be operated either by switches or by voltage sources.

Note: Optional analog outputs are available on 650 **V** - and 650 **W** - versions only.



Active **digital inputs** have **higher priority than RS232** commands.

a) Configuration with switches for digital inputs:

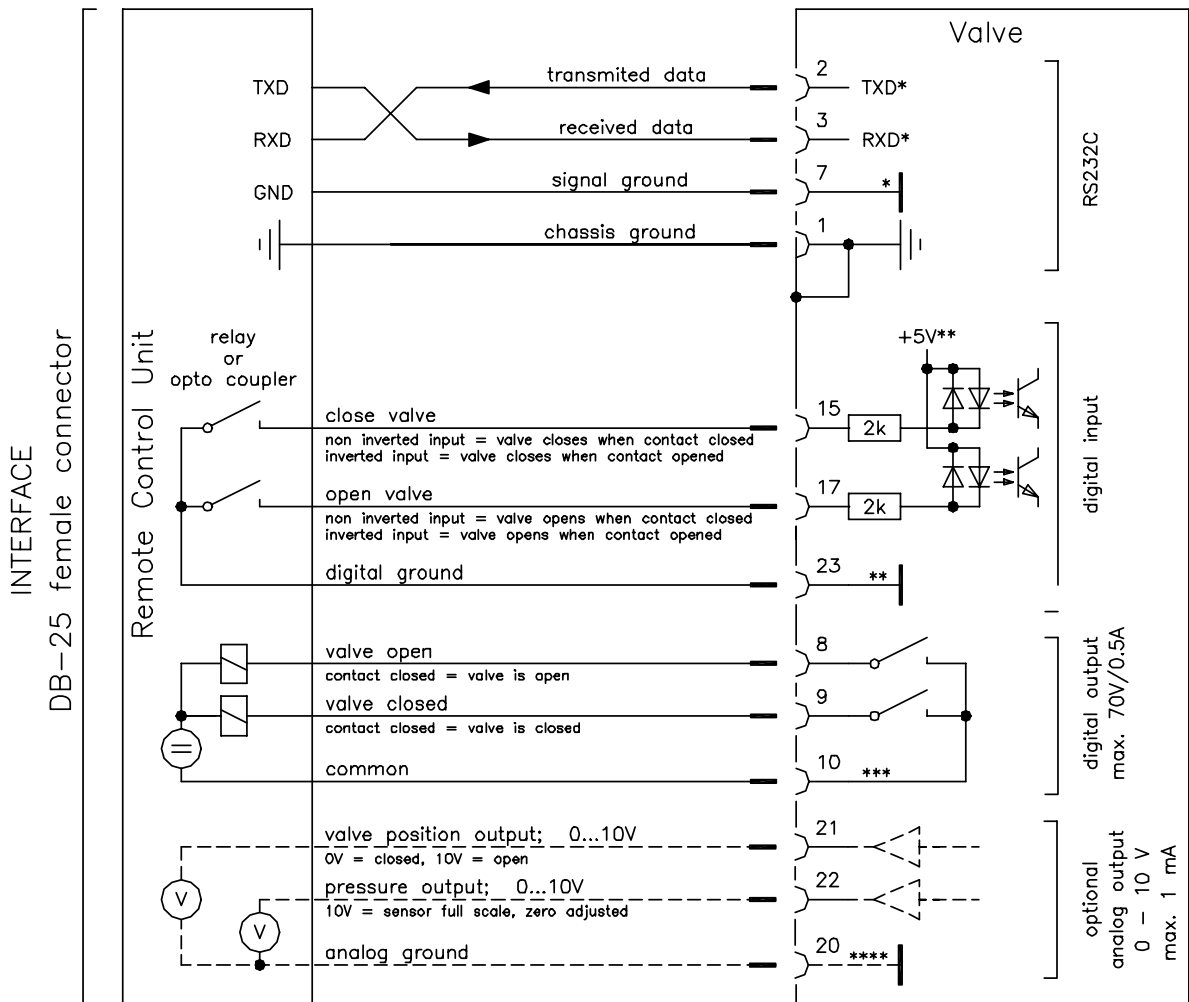

Note: Do not connect other pins than indicated in the schematics above!

b) Configuration with voltage source for digital inputs:

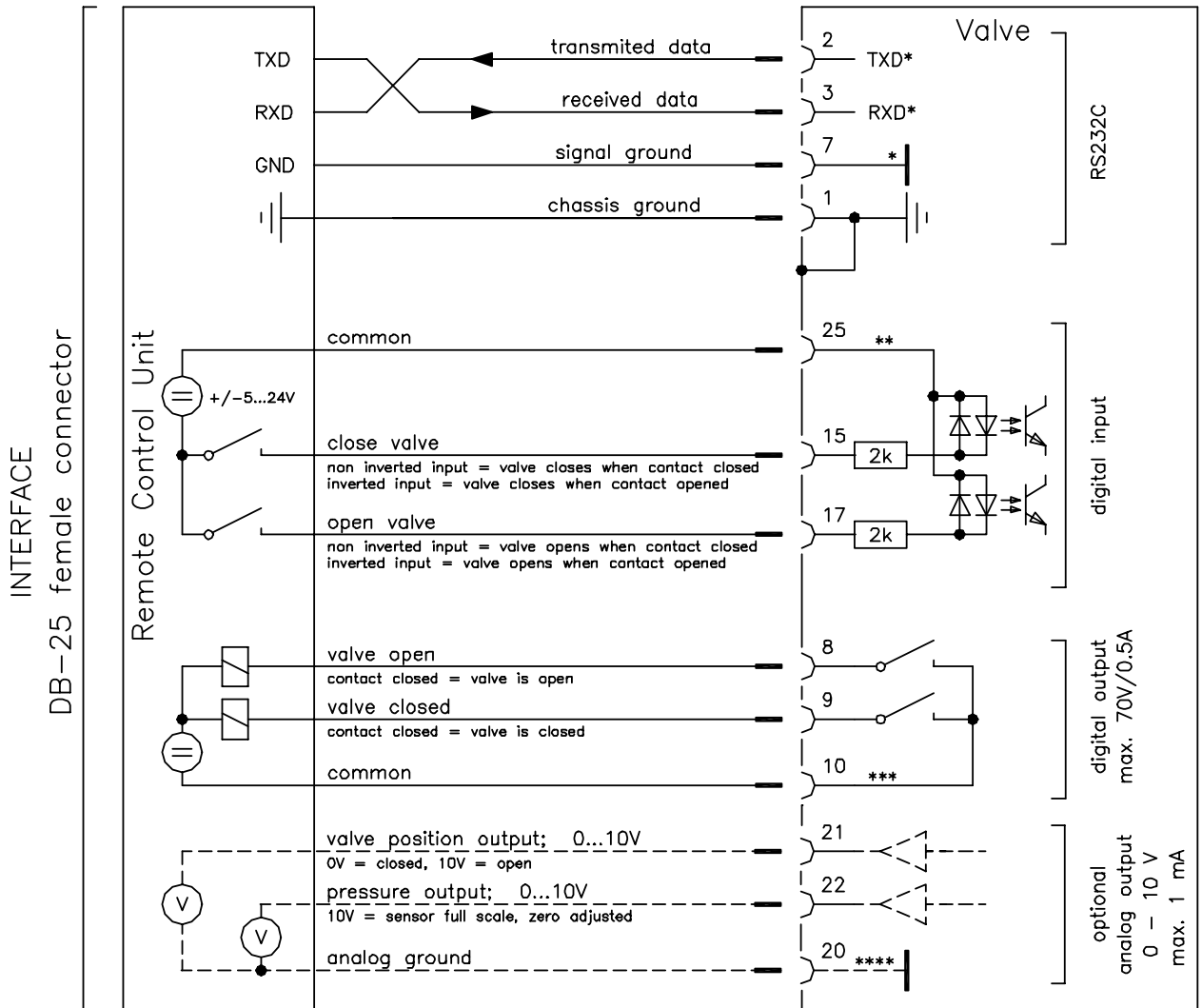

*, **, ***, **** isolated from other circuits

Note: Do not connect other pins than indicated in the schematics above!



3.11.2 Digital inputs

Pin	Function	Signal type	Description	Priority
15	CLOSE VALVE	Digital input ¹⁾	<p>This function will close the valve. Valve will be in interlock mode as long as function is activated. After deactivation of function it will remain effective until</p> <ul style="list-style-type: none">- OPEN valve digital input is active- converse RS232 control command have been received <p>The function is activated when optocoupler is 'on' in non inverted configuration.</p> <p>The function is activated when optocoupler is 'off' in inverted configuration.</p> <p>Configuration can be done in local operation via service port or in remote operation.</p>	1 ²⁾
17	OPEN VALVE	Digital input ¹⁾	<p>This function will open the valve. Valve will be in interlock mode as long as function is activated. After deactivation of function it will remain effective until converse RS232 control command have been received.</p> <p>The function is activated when optocoupler is 'on' in non inverted configuration.</p> <p>The function is activated when optocoupler is 'off' in inverted configuration.</p> <p>Configuration can be done in local operation via service port or in remote operation.</p>	2 ²⁾
23	DIGITAL GROUND	Digital ground	<p>Ground for all digital inputs. Ground is used when digital inputs are operated by switches. Connect switches to ground. See also «3.11.1 Schematics» configuration a).</p>	
25	DIGITAL COMMON	Digital common	<p>Common for all digital inputs. Common is used when digital inputs are driven by voltage sources. Connect + or – terminal of source with common (optocoupler inputs are capable of bidirectional operation). See also «3.11.1 Schematics» configuration b).</p>	

- 1) **All digital inputs are digitally filtered. Filter delay is 50ms. This means that digital signals must be applied for at least 50ms to be effective. Refer to «3.11.1 Schematics» for details about input circuit.**
- 2) **Highest priority is 1. Functions with lower priorities will not be effective as long as higher priority functions are active. These digital inputs have higher priority than all RS232 commands. RS232 commands will not be accepted while digital inputs are active.**



3.11.3 RS232 command syntax

[function][value][CR][LF]

Each element is separated with square brackets for clarity. Square brackets are not part of command syntax. Unless otherwise specified all elements are ASCII characters. There are no spaces between the elements necessary. Commands and values are case sensitive.

Data length of value depends on command. Number of characters is specified in the description. Some commands do not require the value element.

[CR] is Carriage Return (0D hexadecimal).

[LF] is Linefeed

3.11.4 RS232 control commands

Control function	Command		Acknowledgement (within 10ms after reception of command)
	Description		
POSITION CONTROL	Set	[R:][xxxxxx][CR][LF]	[R:][CR][LF]
	Get	[i:38][CR][LF]	[i:38][00xxxxxx][CR][LF]
	xxxxxx	data length 6 characters for writing 8 characters starting with double zero for reading position SETPOINT, value depends on configuration, refer to «3.11.6 RS232 setup commands, RANGE CONFIGURATION» for details Change to POSITION CONTROL mode and transfer of position SETPOINT value resp. reading of position SETPOINT. Note: Reading returns position setpoint only in case pressure control is not selected.	
PRESSURE CONTROL	Set	[S:][0xxxxxxx][CR][LF]	[S:][CR][LF]
	Get	[i:38][CR][LF]	[i:38][0xxxxxxx][CR][LF]
	xxxxxxx	data length 8 characters starting with a zero pressure SETPOINT, value depends on configuration, refer to «3.11.6 RS232 setup commands, RANGE CONFIGURATION» for details Change to PRESSURE CONTROL mode and transfer of pressure SETPOINT resp. reading of pressure SETPOINT. Note: Reading returns pressure setpoint only in case pressure control is selected, otherwise position setpoint is returned.	
HOLD	Set	[H:][CR][LF]	[H:][CR][LF]
	This function stops the valve at the current position. It is effective in PRESSURE CONTROL and POSITION CONTROL. The function can be revoked by a POSITION CONTROL, PRESSURE CONTROL, OPEN VALVE or CLOSE VALVE command.		
CLOSE VALVE	Set	[C:][CR][LF]	[C:][CR][LF]
	Valve will close.		
OPEN VALVE	Set	[O:][CR][LF]	[O:][CR][LF]
	Valve will open.		



3.11.5 RS232 inquiry commands

Inquiry function	Command		Acknowledgement (within 10ms after reception of command)
	Description		
ASSEMBLY	Get	[i:76][CR][LF]	[i:76][xxxxxxsyyyyyyabc][CR][LF]
	<p>data length 17 characters</p> <p>xxxxxx position, return value depends on configuration, refer to «3.11.6 RS232 setup commands, RANGE CONFIGURATION» for details</p> <p>s sign, 0 for positive pressure readings, - for negative pressure readings</p> <p>yyyyyy pressure, return value depends on configuration, refer to «3.11.6 RS232 setup commands, RANGE CONFIGURATION» for details</p> <p>a 0 = local operation, 1 = remote operation, 2 = locked remote operation</p> <p>b 1 = synchronization, 2 = POSITION CONTROL, 3 = CLOSED 4 = OPEN, 5 = PRESSURE CONTROL, 6 = HOLD , 7 = LEARN 8 = INTERLOCK (OPEN by digital input) 9 = INTERLOCK (CLOSED by digital input) C = power failure, D = safety mode E = fatal error (read «FATAL ERROR STATUS» for details)</p> <p>c 0 = no warning, 1 = warning present (read «WARNINGS» and «ERROR STATUS» for details)</p> <p>This function returns an assembly consisting of POSITION, PRESSURE and main status information for the valve.</p>		
POSITION	Get	[A:][CR][LF]	[A:][xxxxxx][CR][LF]
	<p>data length 6 characters</p> <p>xxxxxx position, return value depends on configuration, refer to «3.11.6 RS232 setup commands, RANGE CONFIGURATION» for details</p> <p>This function returns the current valve position.</p> <p>Note: When motor interlock is active during power up the valve enters the 'safety mode' and is not able to recognize position. In this case position 999'999 is returned.</p>		
PRESSURE	Get	[P:][CR][LF]	[P:][sxxxxxx][CR][LF]
	<p>data length 8 characters</p> <p>s sign, 0 for positive readings, - for negative readings</p> <p>xxxxxx pressure, return value depends on configuration, refer to «3.11.6 RS232 setup commands, RANGE CONFIGURATION» for details</p> <p>This function returns the actual pressure.</p>		



Inquiry function	Command		Acknowledgement (within 10ms after reception of command)
	Description		
SENSOR 1 READING	Get	[i:64][CR][LF]	[i:64][sxxxxxxx][CR][LF]
	data length 8 characters s sign, 0 for positive readings, - for negative readings xxxxxxx sensor 1 reading, return value depends on configuration, refer to «3.11.6 RS232 setup commands, RANGE CONFIGURATION» for details This function returns direct reading from sensor 1 input.		
SENSOR 2 READING	Get	[i:65][CR][LF]	[i:65][sxxxxxxx][CR][LF]
	data length 8 characters s sign, 0 for positive readings, - for negative readings xxxxxxx sensor 2 reading, return value depends on configuration, refer to «3.11.6 RS232 setup commands, RANGE CONFIGURATION» for details This function returns direct reading from sensor 2 input.		
PRESSURE CONTROL STATUS	Get	[i:36][CR][LF]	[i:36][abcdefgh][CR][LF]
	data length 8 characters a 0 = no pressure control (e.g. if position control is selected) 1 = wide range control (PD control) 2 = close up control (PID control) cdefgh reserved, do not use The controller distinguishes 2 control ranges and acts accordingly.		
DEVICE STATUS	Get	[i:30][CR][LF]	[i:30][abcdefgh][CR][LF]
	data length 8 characters a 0 = local operation, 1 = remote operation, 2 = locked remote operation b 1 = synchronization, 2 = POSITION CONTROL, 3 = CLOSED 4 = OPEN, 5 = PRESSURE CONTROL, 6 = HOLD, 7 = LEARN 8 = INTERLOCK (OPEN by digital input) 9 = INTERLOCK (CLOSED by digital input) C = power failure, D = safety mode E = fatal error (read «FATAL ERROR STATUS» for details) c 0 = Power Failure Option (PFO) disabled 1 = Power Failure Option (PFO) enabled d 0 = no warning, 1 = warning present (read «WARNINGS» and «ERROR STATUS» for details) efg reserved, do not use h 0 = normal operation, 1 = simulation running This function returns status information about the valve. Note: In simulation mode the valve can demonstrate pressure control capability independent of other equipment such as vacuum chamber, flow controller and gauge. Normal operation is not possible when simulation is running.		



Inquiry function	Command		Acknowledgement (within 10ms after reception of command)
	Description		
WARNINGS	Get	[i:51][CR][LF]	[i:51][abcdefgh][CR][LF]
	<p>data length 8 characters</p> <p>a 0 = no service required 1 = service request, it is indicated when the control unit detects that motor steps are apparently not effective. This may happen when the valve is heavily contaminated or the gate seal is heavily sticking. These 'lost' steps are recognized and will be repeated to attempt target position in the short term. But in the medium term the valve requires cleaning or inspection.</p> <p>b 0 = LEARN data set present, 1 = LEARN data set not present</p> <p>c 0 = power failure battery ready 1 = power failure battery not ready</p> <p>d 0 = compressed air supply ok 1 = compressed air supply not ok</p> <p>efgh reserved, do not use</p> <p>This function returns warning information about the valve. If a warning is present countermeasure should be taken. Use RESET command to delete service request bit. Note: Without LEARN the valve is not able to run pressure control</p>		
SENSOR OFFSET	Set	[i:62][CR][LF]	[i:62][aaaabbbb][CR][LF]
	<p>data length 8 characters</p> <p>aaaa offset sensor 1 (-140 ... 0140 = -1.40V ... +1.40V)</p> <p>bbbb offset sensor 2 (-140 ... 0140 = -1.40V ... +1.40V)</p> <p>This function returns the sensor offset voltages for both sensors (adjusted by ZERO).</p>		
SENSOR 1 OFFSET	Set	[i:60][CR][LF]	[i:60][xxxxxxxx][CR][LF]
	<p>data length 8 characters</p> <p>xxxxxxxx offset sensor 1 (-1400000 ... 01400000 = -1.400000V ... +1.400000V)</p> <p>This function returns the sensor 1 offset voltage (adjusted by ZERO).</p>		
SENSOR 2 OFFSET	Set	[i:61][CR][LF]	[i:61][xxxxxxxx][CR][LF]
	<p>data length: 8 characters</p> <p>xxxxxxxx offset sensor 2 (-1400000 ... 01400000 = -1.400000V ... +1.400000V)</p> <p>This function returns the sensor 2 offset voltage (adjusted by ZERO).</p>		



Inquiry function	Command		Acknowledgement (within 10ms after reception of command)
	Description		
LEARN STATUS	Get	[i:32][CR][LF]	[i:32][abcdefgh][CR][LF]
	<p>data length 8 characters</p> <p>a 0 = LEARN not running, 1 = LEARN running</p> <p>b 0 = LEARN data set present, 1 = LEARN data set not present</p> <p>c 0 = ok 1 = last LEARN interrupted by user (control command) 2 = last LEARN interrupted by control unit (valve open pressure > sensor full scale)</p> <p>d 0 = ok 1 = valve open pressure > 50% sensor full scale (gasflow too high) 2 = valve open pressure < 0 (sensor offset present)</p> <p>e 0 = ok 1 = valve max. throttle pressure < 10% sensor full scale (gasflow too low)</p> <p>f 0 = ok 1 = pressure not raising during LEARN (gasflow missing)</p> <p>g 0 = ok 1 = sensor unstability during LEARN</p> <p>h reserved, do not use</p> <p>This function checks the status of LEARN and indicates if the conditions during LEARN were ok.</p>		
LEARN PRESSURE LIMIT	Get	[i:34][CR][LF]	[i:34][0xxxxxxx][CR][LF]
	<p>data length 8 characters starting with a zero xxxxxxx pressure limit for LEARN, return value depends on configuration, refer to «3.11.6 RS232 setup commands, RANGE CONFIGURATION» for details</p> <p>This function returns the pressure limit applied for LEARN.</p>		
ERROR STATUS	Get	[i:52][CR][LF]	[i:52][abcdefgh][CR][LF]
	<p>data length 8 characters</p> <p>a reserved, do not use</p> <p>b 1 = sensor 1 signal converter failure</p> <p>c reserved, do not use</p> <p>d 1 = firmware memory failure</p> <p>efgh reserved, do not use</p> <p>This function returns an error code in case of any malfunction of the device otherwise 0 is returned.</p>		
FATAL ERROR STATUS	Get	[i:50][CR][LF]	[i:50][abc][CR][LF]
	<p>data length 3 characters</p> <p>abc error code, see «4 Trouble shooting» for details.</p> <p>This function returns an error code in case of any malfunction of the device.</p>		



Inquiry function	Command	Acknowledgement (within 10ms after reception of command)
	Description	
THROTTLE CYCLE COUNTER	Get [i:70][CR][LF]	[i:70][xxxxxxxx][CR][LF]
	data length 10 characters xxxxxxxx number of throttle cycles This function returns the number of throttle cycles. A movement from max. throttle position to open back to max. throttle position counts as one cycle. Partial movements will be added up until equivalent movement is achieved.	
ISOLATION CYCLE COUNTER	Get [i:71][CR][LF]	[i:71][xxxxxxxx][CR][LF]
	data length 10 characters xxxxxxxx number of isolation cycles This function returns the number of isolation cycles. Each closing of the sealing ring counts as one cycle.	
POWER UP COUNTER	Get [i:72][CR][LF]	[i:72][xxxxxxxx][CR][LF]
	data length 10 characters xxxxxxxx number of power ups This function returns the number of control unit power ups.	
HARDWARE CONFIGURATION	Get [i:80][CR][LF]	[i:80][abcdefgh][CR][LF]
	data length 8 characters a 0 = Power Failure Option (PFO) not equipped 1 = Power Failure Option (PFO) equipped b 0 = ±15V sensor power supply (SPS) not equipped 1 = ±15V sensor power supply (SPS) equipped c 2 = RS232 Interface without analog outputs 3 = RS232 Interface with analog outputs d 1 = 1 sensor version, 2 = 2 sensor version e f g h reserved, do not use This function returns the hardware configuration of the device.	
FIRMWARE CONFIGURATION	Get [i:82][CR][LF]	[i:82][xxxxxxx][CR][LF]
	data length 8 characters xxxxxxxx firmware version, e.g. 650P1D00 This function returns firmware version of the device.	
IDENTIFICATION	Get [i:83][CR][LF]	[i:83][xxxxxxxxxxxxxxxxxxxx][CR][LF]
	data length 20 characters xxx...xxx identification code, e.g. 499000/99/0001/, unused digits are filled up with spaces (20 hexadecimal) This function returns an identification code. This code is unique for each valve and allows tracing.	



3.11.6 RS232 setup commands

Setup function	Command		Acknowledgement (within 10ms after reception of command)
	Description		
ACCESS MODE	Set	[c:01][xx][CR][LF]	[c:01][CR][LF]
	data length: 2 characters xx 00 = local operation (service port) 01 = remote operation, change to local enabled 02 = locked remote operation, change to local not possible via service port This function selects the access authorization to the valve. To read access mode use inquiry command DEVICE STATUS. Note: Local operation is only possible when either 'Control View' or 'Control Performance Analyzer' software is running. When communication to service port is interrupted the valve will automatically change to remote operation.		
INTERFACE CONFIGURATION	Set	[s:20][abcdefgh][CR][LF]	[s:20][CR][LF]
	Get	[i:20][CR][LF]	[i:20][abcdefgh][CR][LF]
data length 8 characters a baud rate: 0 = 600, 1 = 1200k, 2 = 2400, 3 = 4800, 4 = 9600 5 = 19.2k, 6 = 38.4k, 7 = 57.6k, 8 = 115.2k b parity bit: 0 = even, 1 = odd, 2 = mark, 3 = space, 4 = no c data length: 0 = 7 bit, 1 = 8 bit d number of stop bits: 0 = 1, 1 = 2 e 0 (reserved, do not change) f digital input OPEN VALVE: 0 = not inverted, 1 = inverted, 2 = disabled g digital input CLOSE VALVE: 0 = not inverted, 1 = inverted, 2 = disabled h 0 (reserved, do not change) This function does the RS232 and digital input configuration. Note: Digital outputs are always enabled.			
VALVE CONFIGURATION	Set	[s:04][abcdefgh][CR][LF]	[s:04][CR][LF]
	Get	[i:04][CR][LF]	[i:04][abcdefgh][CR][LF]
data length 3 characters a valve position after power up: 0 = closed, 1 = open b valve position after power failure: 0 = closed, 1 = open c 0 (reserved, do not change) d 0 (reserved, do not change) e 0 (reserved, do not change) f 0 (reserved, do not change) g 0 (reserved, do not change) h 0 (reserved, do not change) This function does the valve configuration.			



Setup function	Command		Acknowledgement (within 10ms after reception of command)
	Description		
SENSOR CONFIGURATION	Set	[s:01][abcdefgh][CR][LF]	[s:01][CR][LF]
	Get	[i:01][CR][LF]	[i:01][abcdefgh][CR][LF]
	data length	8 characters	
	a	0 = no sensor 1 = 1 sensor operation (sensor 1 input) 2 = 2 sensor operation with automatic changeover (low range = sensor 2 input, high range = sensor 1 input) 3 = 1 sensor operation (sensor 2 input) 4 = 2 sensor operation with automatic changeover (low range = sensor 1 input, high range = sensor 2 input) Note: Sensor operation modes 2, 3 and 4 are possible with 2 sensor hardware (650 H - and 650 W -) only. Note: For applications where the high range sensor is used for monitoring purpose only, select sensor operation modes 1 or 3 for pressure control with low range sensor and read high range sensor from «SENSOR 2 READING» resp. «SENSOR 1 READING».	
	b	1 = ZERO enabled, 0 = ZERO disabled	
cdefgh	High range / Low range sensor full scale ratio * 1'000 (1000 ... 100000). In case of a 1 sensor valve use any value within the valid range.		
This function does the sensor configuration for pressure control.			

Setup function	Command		Acknowledgement (within 10ms after reception of command)
	Description		
RANGE CONFIGURATION	Set	[s:21][abcdefgh][CR][LF]	[s:21][CR][LF]
	Get	[i:21][CR][LF]	[i:21][abcdefgh][CR][LF]
	data length 8 characters a range for POSITION: 0 = 0 – 1'000, 1 = 0 – 10'000, 2 = 0 – 100'000 bcdefgh upper value for PRESSURE and SENSOR READING: 1000 ... 1000000 e.g. 010000 -> pressure range 0 – 10'000		
	This function defines the communication range between the valve and the host computer for POSITION, PRESSURE and SENSOR READING. Note: In case ZERO has been performed, gauge offset for PRESSURE and SENSOR READING is compensated. Note: In case 2 sensor operation for pressure control is selected, PRESSURE covers high range gauge because switchover between sensors is done automatically. SENSOR 1 READING and SENSOR 2 READING always return full scale values according to selected range. Refer also to «3.10.1 Pressure control operation with 2 sensors».		

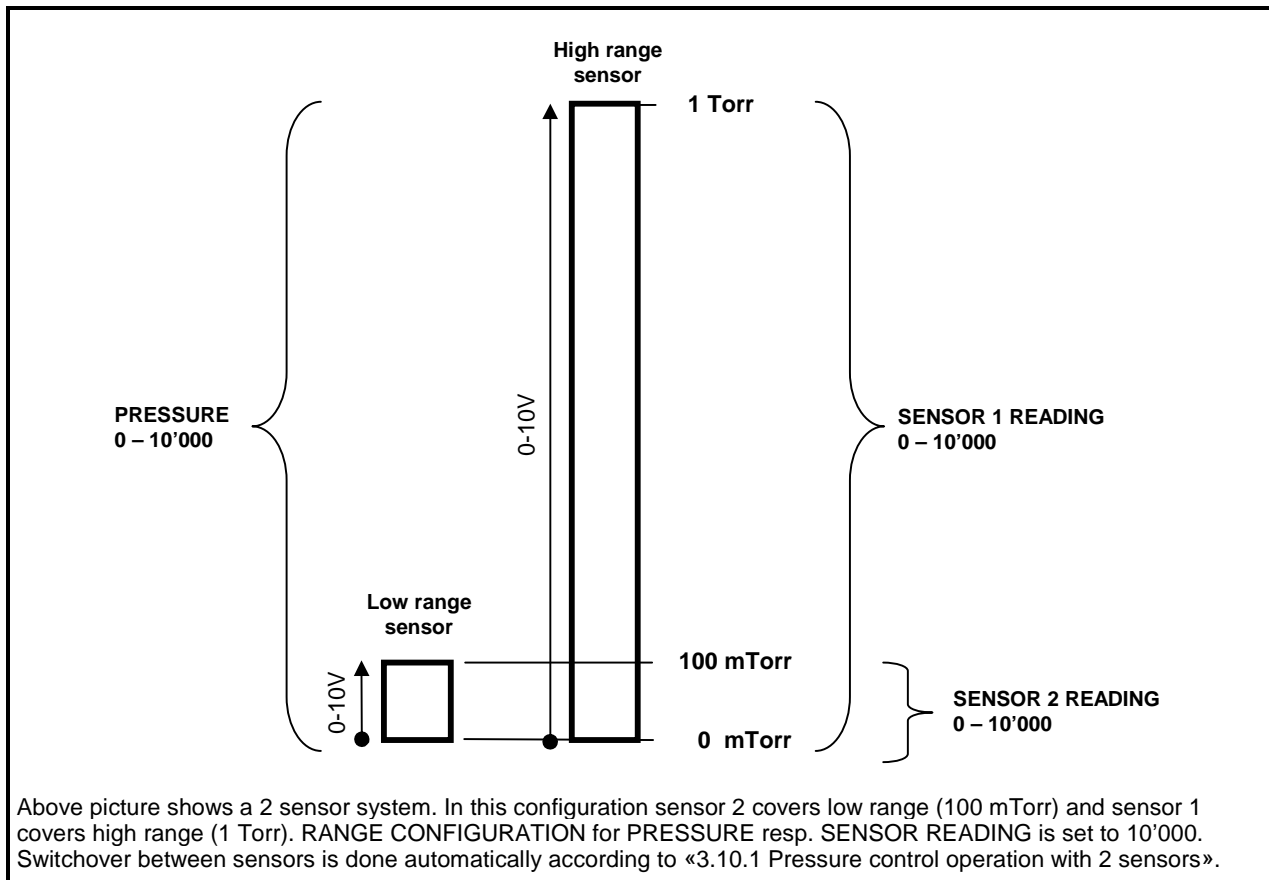



Setup function	Command		Acknowledgement (within 10ms after reception of command)
	Description		
ZERO	Set	[Z:][CR][LF]	[Z:][CR][LF]
	<p>This command initiates ZERO to compensate for offset of gauge(s). Note: Refer to «3.6.3 ZERO» for correct zero procedure.</p>		
PRESSURE ALIGNMENT	Set	[c:6002][xxxxxxx][CR][LF]	[c:60][CR][LF]
	<p>data length: 8 characters xxxxxxx System base pressure, value depends on configuration, refer to «3.11.6 RS232 setup commands, RANGE CONFIGURATION» for details. Alignment range is equivalent to max. +/-1.4V sensor signal. This command aligns PRESSURE to a certain value. Also SENSOR READING will be aligned accordingly. It might be used instead of ZERO in case base pressure is not low enough.</p>		
LEARN	Set	[L:][0xxxxxx][CR][LF]	[L:][CR][LF]
	<p>data length 8 characters starting with a zero xxxxxxx Pressure limit for LEARN, value depends on configuration, refer to «3.11.6 RS232 setup commands, RANGE CONFIGURATION» for details This command starts LEARN. By OPEN VALVE, CLOSE VALVE or POSITION CONTROL commands the routine may be interrupted. Note: Without LEARN the PID controller is not able to perform pressure control. Refer to «3.6.4 LEARN» for correct learn gas flow and procedure.</p>		
DOWNLOAD LEARN DATA	Set	[d:][pppddddddd][CR][LF]	[d:][ppp][CR][LF]
	<p>data length 3 + 8 characters ppp pointer, 000 ... 103 dddddddd single data set This command downloads the LEARN data sets from the host computer to the valve. There are a total number of 104 data sets. Each data set consists of 8 data bytes and needs to be uploaded separately. Note: Make sure that all 104 data sets will be downloaded.</p>		
UPLOAD LEARN DATA	Get	[u:][ppp][CR][LF]	[u:][pppddddddd][CR][LF]
	<p>data length 3 + 8 characters ppp pointer, 000 ... 103 dddddddd single data set This command uploads the LEARN data sets from the valve up to the host. There are a total number of 104 data sets. Each data set consists of 8 data bytes and needs to be uploaded separately. Note: Make sure that all 104 data sets will be uploaded.</p>		



Setup function	Command		Acknowledgement (within 10ms after reception of command)
	Description		
PID CONTROLLER CONFIGURATION	Set	[s:02][abcdefgh][CR][LF]	[s:02][CR][LF]
	Get	[i:02][CR][LF]	[i:02][abcdefgh][CR][LF]
	data length 8 characters a 0 (reserved, do not change) b gain factor: 0 = 0.10, 1 = 0.13, 2 = 0.18, 3 = 0.23, 4 = 0.32, 5 = 0.42, 6 = 0.56 7 = 0.75, 8 = 1.00, 9 = 1.33, A = 1.78, B = 2.37, C = 3.16, D = 4.22 E = 5.62, F = 7.50, G = 0.0001, H = 0.0003, I = 0.001, J = 0.003, K = 0.01, L = 0.02, M = 0.05 c sensor response time: 0 = 0.00, 1 = 0.02, 2 = 0.04, 3 = 0.06, 4 = 0.08, 5 = 0.10, 6 = 0.15, 7 = 0.20, 8 = 0.25, 9 = 0.30, A = 0.35, B = 0.4, C = 0.50, D = 0.60, E = 0.80, F = 1.00 d setpoint ramp time: 0 = 0.0, 1 = 0.5, 2 = 1.0, 3 = 1.5, 4 = 2.0, 5 = 2.5, 6 = 3.0, 7 = 3.5, 8 = 4.0, 9 = 4.5, A = 5.0, B = 5.5, C = 6.0, D = 6.5, E = 7.0, F = 7.5, G = 8.0, H = 8.5, I = 9.0, J = 9.5, K = 10.0 efgh 0000 (reserved, do not change)		
	This command selects gain factor, sensor response time and setpoint ramp for the PID controller. Note: Refer to «3.10.2 Tuning of control performance» for details.		
	This command selects gain factor, sensor response time and setpoint ramp for the PID controller. Note: Refer to «3.10.2 Tuning of control performance» for details.		
VALVE SPEED	Set	[V:][00xxxx][CR][LF]	[V:][CR][LF]
	Get	[i:68][CR][LF]	[i:68][0000xxxx][CR][LF]
	data length 6 characters starting with double zero for writing 8 characters starting with quadruple zero for reading xxxx valve speed, 1 ... 1000 (1 = min. speed, 1000 = max. speed) This command allows changing the actuating speed of the valve plate. Speed selection is effective for pressure control and position control. Open valve and close valve are always done with max. speed. Note: Refer to «3.10.2.4 Valve speed adjustment» for details.		
RESET	Set	[c:82][xx][CR][LF]	[c:82][CR][LF]
	data length 2 characters xx 00 = Reset service request bit from WARNINGS 01 = Reset FATAL ERROR (restart control unit) This function resets warnings and errors.		



3.11.7 RS232 error messages

Description	Error message
Protocol	
Parity error	[E:][000001][CR][LF]
Framing error (data length, number of stop bits)	[E:][000003][CR][LF]
Input buffer overflow (to many characters)	[E:][000002][CR][LF]
Commands	
<CR> or <LF> missing	[E:][000010][CR][LF]
: missing	[E:][000011][CR][LF]
Unknown command	[E:][000020][CR][LF] [E:][000021][CR][LF]
Invalid value	[E:][000022][CR][LF] [E:][000023][CR][LF]
Value out of range	[E:][000030][CR][LF]
Invalid number of characters (between : and [CR][LF])	[E:][000012][CR][LF]
Setup	
ZERO disabled	[E:][000060][CR][LF]
Device Status	
Command not accepted due to local operation	[E:][000080][CR][LF]
Command not accepted due to synchronization, CLOSED or OPEN by digital input, safety mode or fatal error	[E:][000082][CR][LF]
Hardware	
Command not applicable for hardware configuration	[E:][000041][CR][LF]



4 Trouble shooting

Failure	Check	Action
Remote operation does not work	<ul style="list-style-type: none">- Local operation via service port active- Safety mode active, check for D on display?	<ul style="list-style-type: none">- Switch to remote operation.- Provide power to motor to allow for operation.- Refer to «2.6 Electrical connection» for details.
Display shows «E 20» (fatal error - limit stop of valve unit not detected)		<ul style="list-style-type: none">- Replace actuator according to «5.1 Maintenance procedures».
Display shows «E 22» (fatal error - rotation angle of valve plate limited during operation)	<ul style="list-style-type: none">- Valve plate mechanically obstructed?	<ul style="list-style-type: none">- Resolve obstruction.
Display shows «E 40» (fatal error - motor driver failure detected)		<ul style="list-style-type: none">- Replace control unit according to «5.1 Maintenance procedures».
Display shows «D C» or «D999»	<ul style="list-style-type: none">- Motor power supplied?	<ul style="list-style-type: none">- Provide power to motor to allow for operation.- Refer to «2.6 Electrical connection» for details.
Display shows «SR» (Service Request)	<ul style="list-style-type: none">- Valve unit heavy contaminated or gate seal heavily sticking?	<ul style="list-style-type: none">- Clean valve and/or replace gate seal according to «5.1 Maintenance procedures».
CLOSE VALVE does not work	<ul style="list-style-type: none">- Safety mode active, check for D on display?	<ul style="list-style-type: none">- Provide power to motor to allow for operation.- Refer to «2.6 Electrical connection» for details.
OPEN VALVE does not work	<ul style="list-style-type: none">- Safety mode active, check for D on display?	<ul style="list-style-type: none">- Provide power to motor to allow for operation.- Refer to «2.6 Electrical connection» for details.
POSITION CONTROL does not work	<ul style="list-style-type: none">- Safety mode active, check for D on display?	<ul style="list-style-type: none">- Provide power to motor to allow for operation.- Refer to «2.6 Electrical connection» for details.
	<ul style="list-style-type: none">- POSITION CONTROL selected, check for V on display?	<ul style="list-style-type: none">- Select POSITION CONTROL mode.- Refer to «3.9 Position control» for details.
COMPRESSED AIR FAILURE	<ul style="list-style-type: none">- No or too less air pressure on air input of valve	<ul style="list-style-type: none">- Connect air or increase air pressure. Make sure that the air pressure is more than 4 bar (55 psi)



Installation, Operating & Maintenance Instructions
Series 650, DN 320 – 400 (I.D. 12" - 16")

Failure	Check	Action
Pressure reading is wrong or pressure reading is negative	<ul style="list-style-type: none"> - Sensor(s) connected? - 2 sensor version ? 650 H - or 650 W - - ZERO done? - Does sensor power supply provide enough power for sensor(s)? 	<ul style="list-style-type: none"> - Refer to «2.6 Electrical connection». - Verify configuration. - Refer to «3.10.1 Pressure control operation with 2 sensors». - Perform ZERO when base pressure is reached. Refer to «3.6.3 ZERO» for details. - Verify sensor supply voltage.
ZERO does not work	<ul style="list-style-type: none"> - Valve in open position, check for O on display? - ZERO disabled? 	<ul style="list-style-type: none"> - OPEN VALVE and bring chamber to base pressure before performing ZERO. - Enable ZERO. Refer to «3.6.2 Valve and sensor configuration» for details.
Pressure is not '0' after ZERO PRESSURE CONTROL does not work	<ul style="list-style-type: none"> - Sensor voltage shifting? - System pumped to base pressure? - Sensor offset voltage exceeds $\pm 1.4V$ - Safety mode active, check for D on display? - PRESSURE CONTROL selected, check for P on display? - LEARN done? 	<ul style="list-style-type: none"> - Wait until sensor does not shift any more before performing ZERO. - OPEN VALVE and bring chamber to base pressure before performing ZERO. - Replace pressure gauge. - Provide power to motor to allow for operation. Refer to «2.6 Electrical connection» for details. - Select PRESSURE CONTROL mode. Refer to «3.10 Pressure control» for details. - Perform LEARN. Refer to «3.6 Setup procedure» for details.
PRESSURE CONTROL not optimal	<ul style="list-style-type: none"> - Setup done completely? - LEARN done? - ZERO performed before LEARN? - LEARN interrupted? - Was gas flow stable during LEARN? - Tuning done? - Is sensor range suited for application? - Noise on sensor signal? 	<ul style="list-style-type: none"> - Perform «3.6 Setup procedure» completely. - Perform LEARN. Refer to «3.6.4 LEARN» for details. - Perform ZERO then repeat LEARN. Refer to «3.6 Setup procedure» for details. - Repeat LEARN. Refer to «3.6.4 LEARN» for details. - Repeat LEARN with stable gas flow. Refer to «3.6.4 LEARN» for details. - Tune valve for application. Refer to «3.10.2 Tuning of control performance» for details. - Use a sensor with suitable range (controlled pressure should be >3% and < 98% of sensor full scale). - Make sure a shielded sensor cable is used.

If you need any further information, please contact one of our service centers. You can find the addresses on our website: <http://www.vat.ch>



5 Maintenance & repairs

Under clean operating conditions, the valve does not require any maintenance during the specified cycle life. Contamination from the process may influence the function and requires more frequent maintenance.

Before carrying out any maintenance or repairs, please contact VAT. It has to be individually decided whether the maintenance/repair can be performed by the customer or has to be carried out by VAT. The fabrication number on the valve

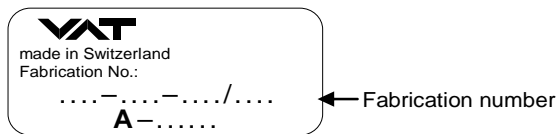

has always to be specified.

All supplies (e. g. compressed air, electrical power) must be disconnected for removal/installation of the valve from/into the system.



Even with disconnected supply, loaded springs and/or air cushions in cylinders can be potential hazards.



Keep fingers and objects away from the valve opening!

Products returned to VAT must be free of harmful substances such as e.g. toxic, caustic or micro-biological ones. If products are radioactively contaminated, fill in the VAT form «Contamination and Radiation Report» and send it with the product. The form is available at VAT. The maximum values indicated in the form must not be exceeded.

5.1 Maintenance procedures



Keep fingers out of the valve during maintenance work.

Two preventive maintenance procedures are defined for this valve. These are:

- **Replacement of isolation seals (gate and body seal of sealing ring) and valve cleaning**
- **Replacement of actuator feedthrough seals**



Required frequency of cleaning and replacement of seals is depending on process conditions.

A critical factor influencing the maintenance period is the lifetime of the vacuum grease, being limited under increased temperature. In this case grease will separate to PTFE and oil. The oil may flow and contaminate the valve parts.

VAT can give the following **recommendations for preventive maintenance**:

	unheated *)	heated $\leq 80^{\circ}\text{C}$ *)	heated $> 80^{\circ}\text{C}$ *)
isolation seals (gate and body seal of sealing ring)	200'000 cycles	6 months but max. 200'000 cycles	3 months but max. 200'000 cycles
actuator feedthrough seals	1 Mio. cycles	6 months	3 months

*) This figures are reference values for clean conditions under various temperatures. These values do not include any impact of the process. Therefore preventive maintenance schedule has finally to be checked for the actual process conditions.



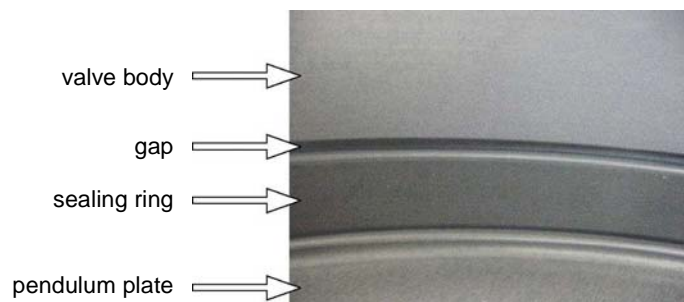

Prevent gap between body and sealing ring from air gun cleaning. Otherwise vacuum grease may be distributed and contaminate the valve.





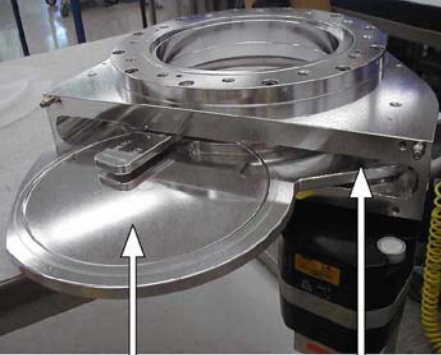
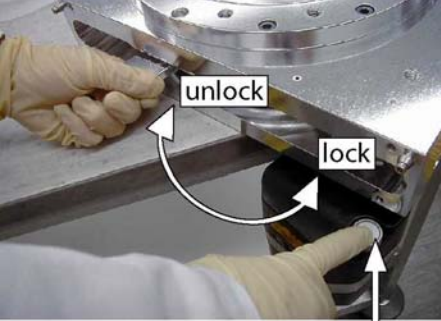

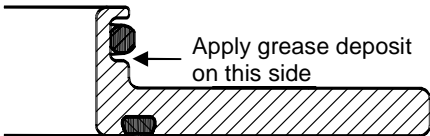
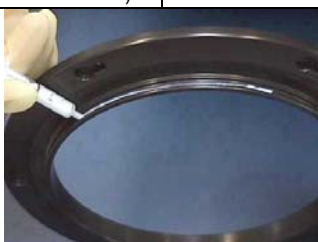

Replacement of isolation seals (gate and body seal of sealing ring) and valve cleaning

Replacement of actuator feedthrough seals

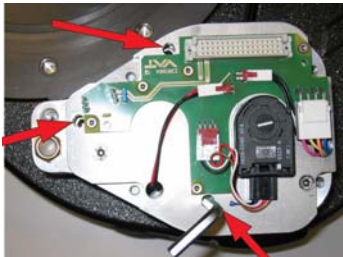

Description	Required tool												
<p>1. Vent both valve chambers.</p> <p>2. Open bonnet screws. Press snap in fixation on one side and pull bonnet a little bit on that side. Than press snap in fixation on other side and remove valve bonnet.</p> <table border="1" data-bbox="204 685 592 898"> <thead> <tr> <th colspan="2">Caution:</th> </tr> <tr> <th colspan="2">Weight of valve bonnet is approx.</th> </tr> </thead> <tbody> <tr> <td>DN320 / 12" (65050 - -)</td> <td>13 kg (29 lbs.)</td> </tr> <tr> <td>DN350 / 14" (65051 - -)</td> <td>15 kg (33 lbs.)</td> </tr> <tr> <td>DN400 / 16" (65052 - -)</td> <td>18 kg (40 lbs.)</td> </tr> </tbody> </table>	Caution:		Weight of valve bonnet is approx.		DN320 / 12" (65050 - -)	13 kg (29 lbs.)	DN350 / 14" (65051 - -)	15 kg (33 lbs.)	DN400 / 16" (65052 - -)	18 kg (40 lbs.)		<p>Allen wrench 8mm</p>	
Caution:													
Weight of valve bonnet is approx.													
DN320 / 12" (65050 - -)	13 kg (29 lbs.)												
DN350 / 14" (65051 - -)	15 kg (33 lbs.)												
DN400 / 16" (65052 - -)	18 kg (40 lbs.)												
<p>3. Open valve</p> <p>Caution: Stand away from valve – pendulum plate moves out of the valve body.</p> <p>4. To prevent the pendulum plate from moving during work, switch the valve to safety mode. Refer to «3.1.3 Safety mode» for details.</p> <p>5. Unfasten mounting screw for pendulum plate.</p> <p>6. Remove pendulum plate.</p>		<p>open end wrench 13mm</p>											
<p>7. With one hand press the MAINTENANCE BUTTON to lower the sealing ring, with your second hand unlock the sealing ring by pressing the handle.</p> <p>8. Release MAINTENANCE BUTTON.</p> <p>9. Remove sealing ring.</p>													

Description	Required tool									
<p>10. Remove gate and body o-ring from sealing ring carefully with a soft tool.</p> <p>11. Remove grease residues at sealing ring with alcohol. Clean sealing ring and pendulum plate with alcohol or in an ultrasonic bath.</p> <p>12. Clean out valve body with alcohol. Use an appropriate non metal tool with a cloth to enter valve body. Do not enter valve body with hands! Then blow out valve body with clean air. Do not directly expose seals (actuator and retaining pin feedthroughs) to air stream!</p> <p>13. Clean or replace gate seal if necessary. Install gate o-ring to sealing ring without grease.</p>	 <p style="text-align: center;">gate seal</p> <p style="text-align: center;">body seal</p>									
<p>14. Clean or replace body seal if necessary. Lubricate body o-ring with the quantity of vacuum grease listed in the table to the right.</p>		<table border="1"> <thead> <tr> <th>Valve size</th> <th>Quantity of grease [ml]</th> </tr> </thead> <tbody> <tr> <td>DN320 / 12" (65050 - -)</td> <td>0.3</td> </tr> <tr> <td>DN350 / 14" (65051 - -)</td> <td>0.4</td> </tr> <tr> <td>DN400 / 16" (65052 - -)</td> <td>0.4</td> </tr> </tbody> </table>	Valve size	Quantity of grease [ml]	DN320 / 12" (65050 - -)	0.3	DN350 / 14" (65051 - -)	0.4	DN400 / 16" (65052 - -)	0.4
Valve size	Quantity of grease [ml]									
DN320 / 12" (65050 - -)	0.3									
DN350 / 14" (65051 - -)	0.4									
DN400 / 16" (65052 - -)	0.4									
<p>15. Install body o-ring into sealing ring.</p>										
<p>16. Deposit vacuum grease on the bottom side of the body seal according to drawing below. Pay attention that the quantity of vacuum grease listed in the table to the right is distributed constantly over the whole circumference.</p>	<table border="1"> <thead> <tr> <th>Valve size</th> <th>Quantity of grease [ml]</th> </tr> </thead> <tbody> <tr> <td>DN320 / 12" (65050 - -)</td> <td>0.5</td> </tr> <tr> <td>DN350 / 14" (65051 - -)</td> <td>0.7</td> </tr> <tr> <td>DN400 / 16" (65052 - -)</td> <td>1.1</td> </tr> </tbody> </table>	Valve size	Quantity of grease [ml]	DN320 / 12" (65050 - -)	0.5	DN350 / 14" (65051 - -)	0.7	DN400 / 16" (65052 - -)	1.1	
Valve size	Quantity of grease [ml]									
DN320 / 12" (65050 - -)	0.5									
DN350 / 14" (65051 - -)	0.7									
DN400 / 16" (65052 - -)	1.1									
 <p style="text-align: center;">Apply grease deposit on this side</p>										

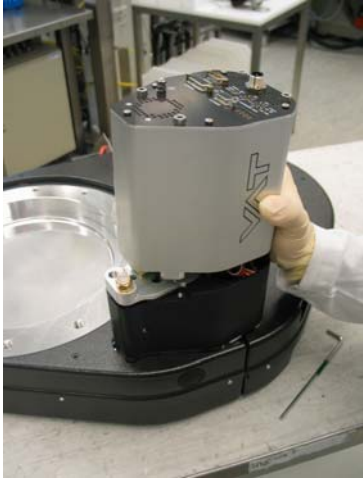
Description		Required tool	
<p>17. Release the valve from safety mode. Refer to «Safety mode» for details</p> <p>18. Move the valve to position 50% (half opened) This is necessary, in order to dismount the actuator. See 21/22</p> <p>19. Disable PFO option feature via 'Power Fail Status' in menu 'System' of CV or CPA software, and turn off the power</p>		<p>CV or CPA software</p> <p>or</p> <p>Service Box 2</p>	
<p>20. Disconnect 24VDC power. Wait for 60s, then disconnect cable and compressed air from valve actuator.</p> <p>21. Unfasten all 4 controller screws and lift controller carefully from actuator. Unfasten the 4 screws of the shift adaptor plate and remove it carefully.</p>		<p>Allen Wrench 4 mm</p>	
<p>22. Unfasten all 3 actuator screws and remove actuator. If you can't see the screws, please move the plate manually to half-open position. This can be done, when the "sealing"-ring has been removed.</p>		<p>Allen Wrench 5 mm</p>	
<p>23. Remove actuator shaft seals carefully with a soft tool.</p> <p>24. Clean actuator feedthrough with alcohol.</p> <p>25. Lubricate each o-ring groove with 0.1 ml vacuum grease. Pay attention that grease is distributed constantly over the whole circumference.</p>			

Description	Required tool		
<p>26. Clean or replace seals if necessary. Lubricate each o-ring with 0.05 ml vacuum grease.</p> <p>27. Install o-rings.</p> <p>28. Deposit 0.1 ml vacuum grease on each o-ring. Pay attention that grease is distributed constantly over the whole circumference.</p>			
<p>29. Remove fixation kit and mounting screw for pendulum plate.</p> <p>30. Clean screw and slightly lubricate thread. Then reinstall fixation kit.</p> <p>31. Clean actuator shaft and lubricate it with 0.1 ml vacuum grease.</p>			
<p>32. Install actuator and controller in reverse order as they had been disassembled (steps 22 to 20).</p> <ul style="list-style-type: none"> • Tighten actuator screws with 6 Nm. • Remove vacuum grease from actuator shaft face after installation. • Tighten controller driver screws with 3 Nm. 		<p>Allen Wrench 4mm and 5mm</p>	

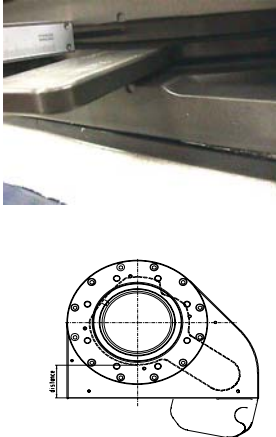

Description		Required tool									
33. Turn on power of controller. Note: valve moves to close position. 34. Open valve and install sealing ring and pendulum plate in reverse order as they had been disassembled (steps 9 to 2).		open end wrench 13mm									
If actuator was replaced , proceed with point 35, otherwise go to point 37. 35. Close valve and check if pendulum plate is in center of flange. Check can be done either visual or by measurement. When the valve is mounted to a tool, the bonnet has to be removed and the center position can be measured by a depth gauge (see picture). If the centering (or distance) is not correct, proceed with point 36.		<table border="1"> <tr> <td data-bbox="1147 645 1187 770">DN</td> <td data-bbox="1187 645 1353 770">Distance between bonnet flange surface and pendulum plate D[mm]</td> </tr> <tr> <td data-bbox="1147 770 1187 875">320</td> <td data-bbox="1187 770 1353 875">60.5 ±0.5</td> </tr> <tr> <td data-bbox="1147 875 1187 981">350</td> <td data-bbox="1187 875 1353 981">59.0 ±0.5</td> </tr> <tr> <td data-bbox="1147 981 1187 1093">400</td> <td data-bbox="1187 981 1353 1093">62.0 ±0.5</td> </tr> </table>	DN	Distance between bonnet flange surface and pendulum plate D[mm]	320	60.5 ±0.5	350	59.0 ±0.5	400	62.0 ±0.5	
DN	Distance between bonnet flange surface and pendulum plate D[mm]										
320	60.5 ±0.5										
350	59.0 ±0.5										
400	62.0 ±0.5										
36. If necessary adjust pendulum plate: <ol style="list-style-type: none"> Move pendulum plate a little towards open (e.g. position 1% of full stroke) Use adjustment screw at flange side of actuator (1 turn clockwise adjusts pendulum plate by about 3mm towards open). Restart valve in menu 'System/Recovery' Check pendulum plate position according point 35 and redo adjustment procedure if necessary. 		Allen wrench 2mm									
37. Mount valve bonnet. <ul style="list-style-type: none"> Tightening torques for bonnet screws are listed in the table to the right. 	Max. torque 16 Nm	Allen wrench 5mm									

5.2 Option board

The option board may or may not be equipped in your valve depending on the order. Refer to page 1 of this manual to check valve version. This board includes the optional modules for the valve which are:

- ± 15 VDC sensor power supply (SPS)
- Power failure option (PFO)

It is available in 3 versions. These are:

- SPS module only
- PFO module only
- SPS and PFO module

The modules may be retrofitted or replaced easily. The battery lifetime of the PFO module depends on the ambient temperature (see below). To assure PFO function the option board must be replaced after battery life has expired. For ordering number of the modules refer to «Spare parts and accessories».

5.2.1 Durability of power fail battery

The curves in the graph show the estimated life of UltraCap PFO in the worst condition (max. sensor load = 1 A, valve heating temperature = 150 degree C).

If the SPS is not fully loaded (< 1 A) or heating temperature of valve body is lower than 150 degree C, the corresponding life time curve will be somewhere in between the upper and the lower curve.

Therefore please determine the equivalent maintenance period for replacing the UltraCap battery (Option board).

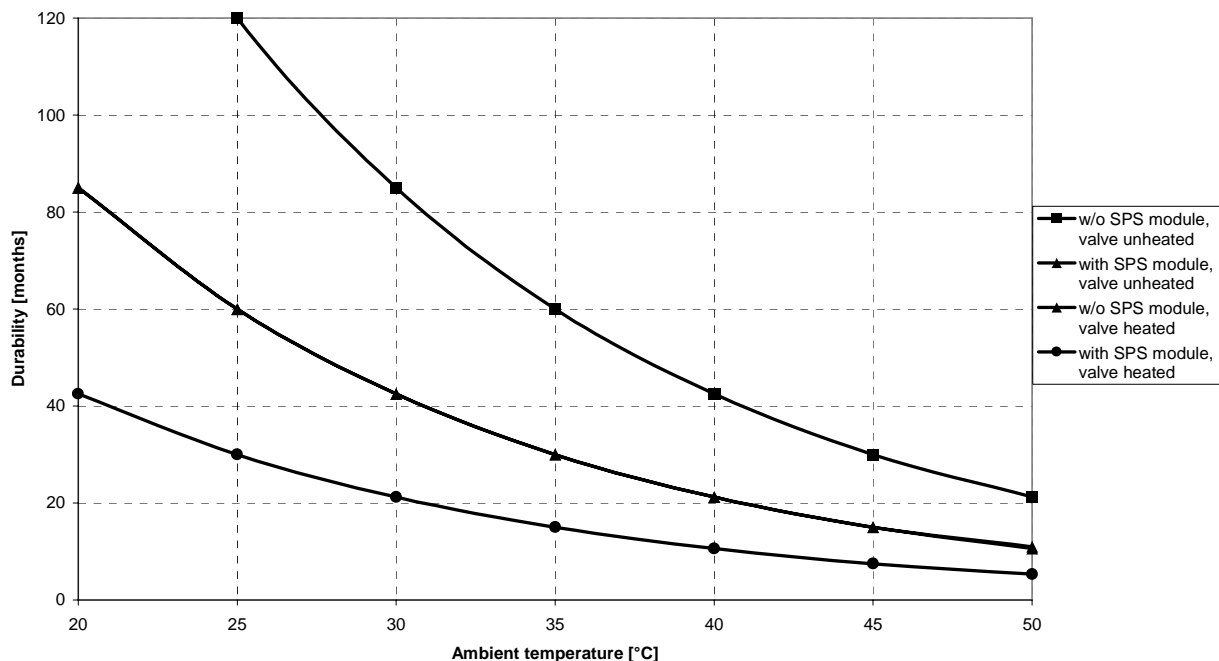

Note: This graph shows estimated life of UltraCap PFO for reference and not as guaranteed value.

5.2.2 Retrofit / replacement procedure





ESD Precaution!

All work on the control and actuating unit has to be done under ESD protected environment to prevent electronic components from damage!

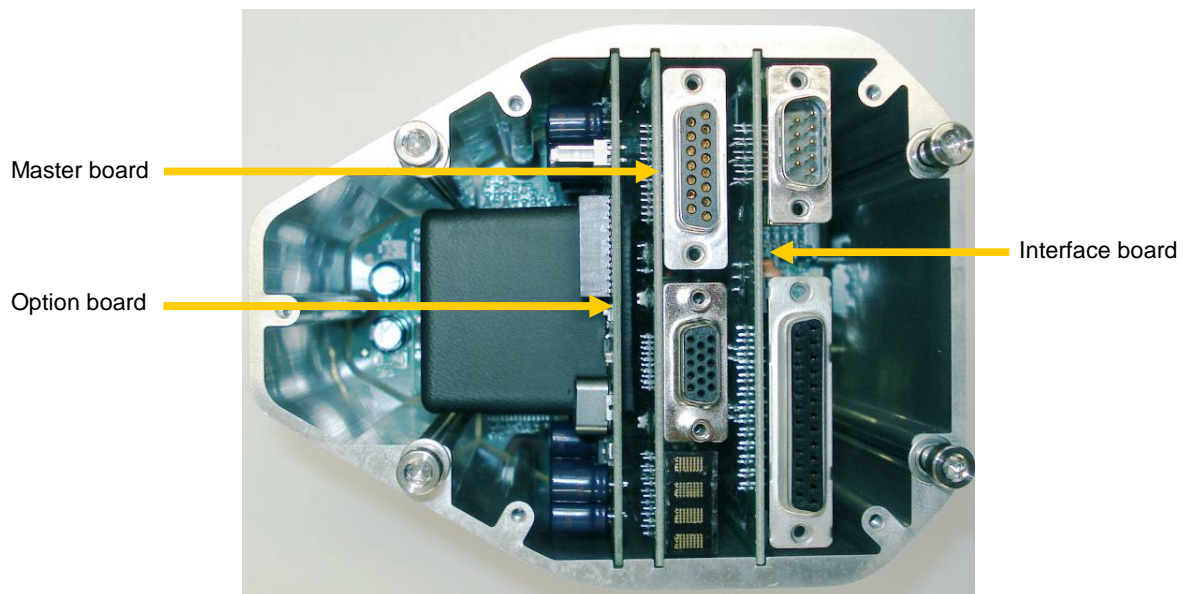
Top view on control and actuating unit with panel removed:

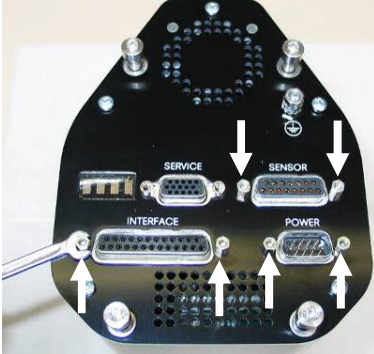

Note: All boards have a fixed position into control and actuating unit. It is not possible to fit a board in other position as shown in picture above. Do not try out other positions, that may be destroy the socket of boards!

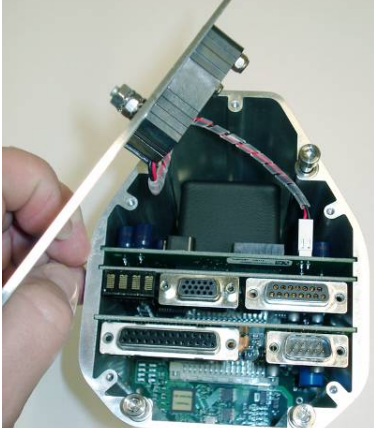
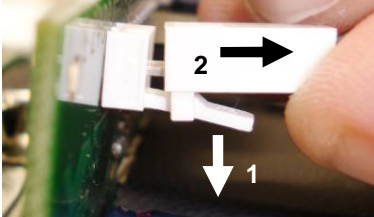
Description		Required tool
<p>1. Remove female screw locks from POWER, SENSOR and INTERFACE connectors.</p>		<p>Open end wrench 4.5 mm</p>
<p>2. Remove the panel screws.</p>		<p>Pozidriv screw driver size 1</p>
<p>3. Lift the panel carefully.</p>		
<p>4. Pull out the option board a little. 5. Push the connector release (1) a little down and disconnect fan cable (2) from option board.</p>		

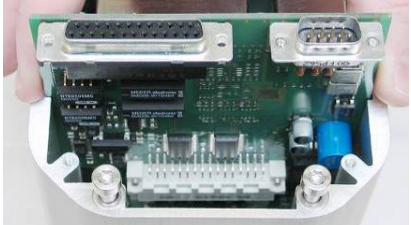
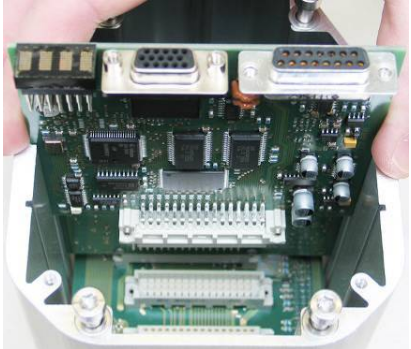
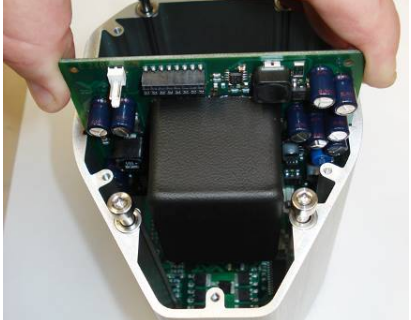
Description		Required tool
6. Remove or replace interface board.		
7. Remove or replace master board.		
8. Remove or replace option board.		
9. Insert master board and interface board in reverse order as disassembled at correct positions (see steps 7 to 6).		
10. Reconnect fan cable to option board (see steps 5 to 4).		
11. Place the panel and tighten panel screws with 1.1 Nm (see steps 3 to 2).		Pozidriv screw driver size 1
12. Tighten female screw locks from POWER, SENSOR and INTERFACE connectors with 1.1 Nm (see step 1).		Open end wrench 4.5 mm

6 Drawing

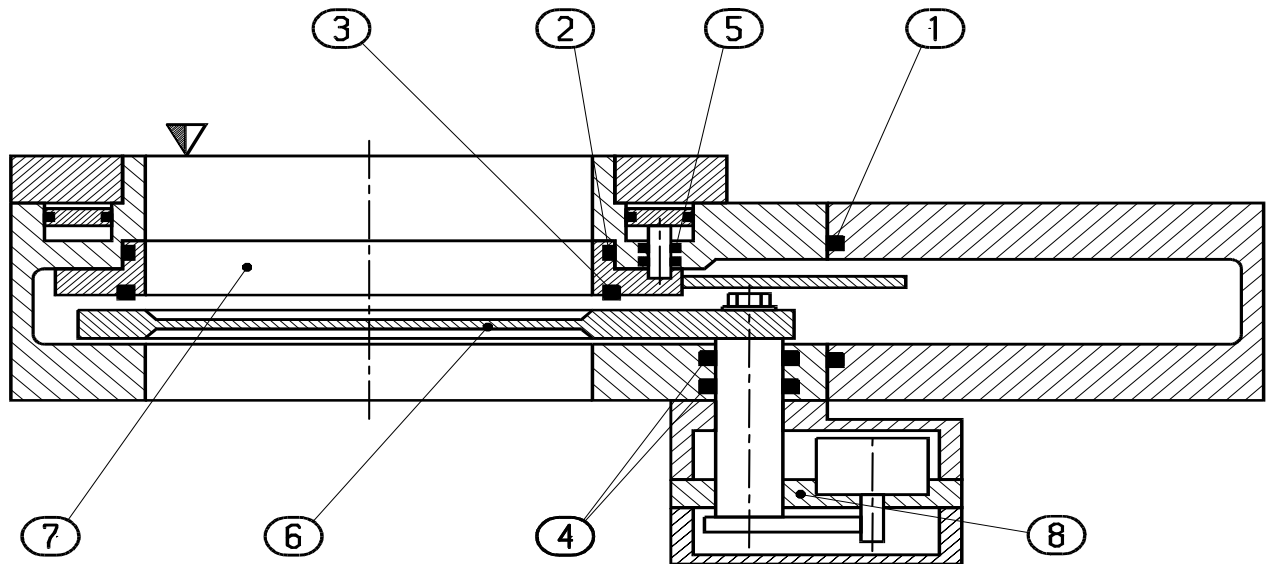



7 Spare parts and accessories

The item numbers refer to the drawing on page 60



Please specify the **fabrication number of the valve** (see yellow label on valve) when ordering spare parts. This is to ensure that the appropriate spare parts are supplied.

7.1 Accessories

Item	Description	
	Valve size	All sizes
	Product ordering number	650
	24 VDC power supply unit (input: 100 – 240 VAC)	249775
	'Control Performance Analyzer' package for Windows® consisting of software and cable	600SP-99NN-AAA
	'Control View' software for Windows®	248126 free download from www.vatvalve.com or available on order against charge
	Service cable (PC to valve connection)	230327 free wiring information available for download from www.vatvalve.com
	Connector kit consisting of: •DB-9 female POWER plug •DB-15 male SENSOR plug •DB-25 male INTERFACE plug	242411

Item	Description					
	Valve size		DN 320 / 12"	DN 350 / 14"	DN 400 / 16"	
	Product ordering number		65050 -	65051 -	65052 -	
	Centering ring with Viton o-ring (for ISO-F installation only)	Aluminum	32050-QAZV	-	32052-QAZV	

7.2 Control unit

Item	Description	
	Valve size	All sizes
	Product ordering number	650
	Control unit	Too many to list. Depends on configuration, please contact VAT.
	Option board with SPS module (±15VDC sensor power supply)	371399
	Option board with PFO module (power failure option)	371397
	Option board with SPS and PFO module	326113



7.3 Valve unit

Item	Description	Valve size		
		DN 320 / 12"	DN 350 / 14"	DN 400 / 16"
	Valve part number	65050 -	65051 -	65052 -
1	Bonnet Viton seal other materials	N-5100-280 on request	N-5100-281 on request	N-5100-282 on request
2	Body seal (Viton) This includes a 2ml syringe of vacuum grease	206529	230885	244435
3	Gate Viton seal other materials	N-5100-279 on request	N-5100-280 on request	N-5100-282 on request
	Seal kit vacuum (Viton). This consists of item 2 and 3.	206528	230884	244437
	Syringe of vacuum grease 2ml 5ml		206792 206793	
4	Actuator feedthrough seals (Viton)	on request	on request	on request
5	Seals for sealing ring shaft feedthroughs (Viton)		N-7121-112 (24 pcs required per valve)	
6	Pendulum plate:			
	- Blank B1 *)	on request	on request	on request
	- Blank B2 *)	on request	on request	on request
	- Hardanodized B1 *)	on request	on request	on request
	- Hardanodized B2 *)	on request	on request	on request
	- Nickel coated B1 *)	on request	on request	on request
	- Nickel coated B2 *)	on request	on request	on request
	- Stainless steel B1 *)	on request	on request	on request
- Stainless steel B2 *)	on request	on request	on request	
7	Sealing ring			
	- Blank	230236	217677	239438
	- Hardanodized	229310	222784	235224
	- Nickel coated	on request	211610	on request
8	Actuator complete B1 *) (incl. motor driver) B2 *)	on request on request	on request on request	on request on request

Note: Use only spare parts manufactured by VAT to assure safe and reliable operation!

*) Refer to figures on next page to check for actuator position options.

Actuator position options:

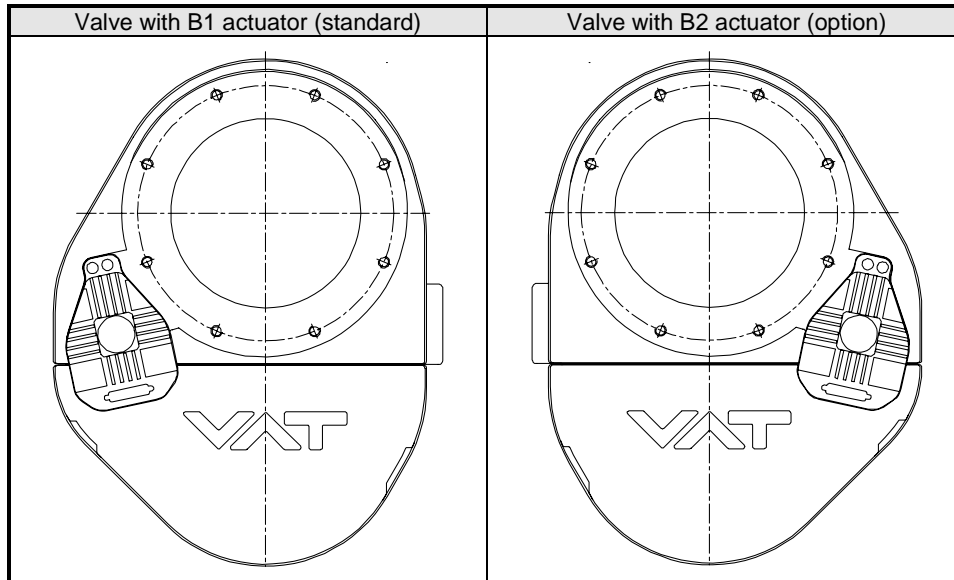

8 Warranty

Each product sold by VAT Vakuumentile AG (VAT) is warranted to be free from the manufacturing defects that adversely affect the normal functioning thereof during the warranty period stated in VAT's «Terms of Sale» immediately following delivery thereof by VAT, provided that the same is properly operated under conditions of normal use and that regular, periodic maintenance and service is performed or replacements made, in accordance with the instructions provided by VAT. The foregoing warranty shall not apply to any product or component that has been repaired or altered by anyone other than an authorized VAT representative or that has been subject to improper installation or abuse, misuse, negligence or accident. VAT shall not be liable for any damage, loss, or expense, whether consequential, special, incidental, direct or otherwise, caused by, arising out of or connected with the manufacture, delivery (including any delay in or failure to deliver), packaging, storage or use of any product sold or delivered by VAT shall fail to conform to the foregoing warranty or to the description thereof contained herein, the purchaser thereof, as its exclusive remedy, shall upon prompt notice to VAT of any such defect or failure and upon the return of the product, part or component in question to VAT at its factory, with transportation charges prepaid, and upon VAT's inspection confirming the existence of any defect inconsistent with said warranty or any such failure, be entitled to have such defect or failure cured at VAT's factory and at no charge therefor, by replacement or repair of said product, as VAT may elect. VAT MAKES NO WARRANTY OR REPRESENTATION OF ANY KIND, EXPRESS OR IMPLIED, (INCLUDING NO WARRANTY OR MERCHANTABILITY), EXCEPT FOR THE FOREGOING WARRANTY AND THE WARRANTY THAT EACH PRODUCT SHALL CONFORM TO THE DESCRIPTION THEREOF CONTAINED HEREIN, and no warranty shall be implied by law.

Furthermore, the «Terms of sale» at the back of the price list are applicable.