

All-Metal Angle Valve with single acting pneumatic actuator with closing spring

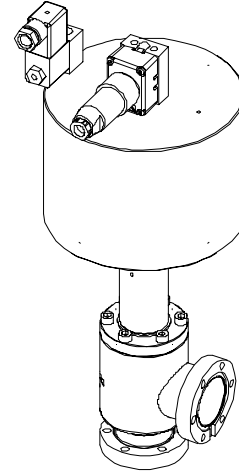

This manual is valid for the valve ordering number(s):

57132- . E11

57132- . E21

57132- . E31

57132- . E41

The fabrication number is indicated on each product as per the label below (or similar):

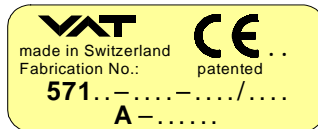

← Fabrication number

Explanation of symbols:



Read declaration carefully before you start any other action!



Keep body parts and objects away from the valve opening!



Attention!



Hot surfaces; do not touch!



Product is in conformity with EC guidelines, if applicable!



Loaded springs and/or air cushions are potential hazards!



Disconnect electrical power and compressed air lines. Do not touch parts under voltage!



Wear gloves!



Read these «**Installation, Operating & Maintenance Instructions**» and the enclosed «**General Safety Instructions**» carefully before you start any other action!



Installation, Operating & Maintenance Instructions
Series 571, DN 40 (I.D. 1 1/2")

Imprint:

Manufacturer VAT Vakuumventile AG, CH-9469 Haag, Switzerland

Website
www.vatvalve.com

Phone
+41 81 771 61 61

Fax
+41 81 771 48 30

Email
CH@vatvalve.com

Publisher VAT Vakuumventile AG, CH-9469 Haag, Switzerland

Editor VAT Vakuumventile AG, CH-9469 Haag, Switzerland

Print VAT Vakuumventile AG, CH-9469 Haag, Switzerland

Copyright © VAT Vakuumventile AG 2008

No part of these Instructions may be reproduced in any way (photocopies, microfilms or any other reproduction processes) nor may it be manipulated with electronic systems, duplicated or distributed without written permission from VAT. Offenders are liable to pay damages.

The original VAT firmware and updated state of the art versions of the VAT firmware are intended for use with VAT products. The VAT firmware contains a limited, time unlimited user license. The VAT firmware may not be used for purposes other than those intended nor is it permitted to make copies of the VAT firmware. In particular, it is strictly forbidden to give copies of the VAT firmware to other people.

The use of trade names, brand names, trademarks, etc. in these Instructions does not entitle third parties to consider these names to be unprotected and to use them freely. This is in accordance with the meaning of the laws and acts covering brand names and trademarks.



Contents:

1	Use of product	4
1.1	Technical data	4
2	Installation.....	4
2.1	Unpacking	4
2.2	Installation into the system.....	4
2.3	Connections	5
2.3.1	Compressed air connection	5
2.3.2	Electrical connection	6
3	Operation	7
3.1	Normal operation.....	7
3.2	Bake out	8
3.3	Operation under increased temperature	8
3.4	Behavior in case of compressed air pressure drop.....	8
3.5	Behavior in case of power failure	8
3.6	Emergency operation at power failure	8
4	Trouble shooting	9
5	Maintenance & repairs	9
5.1	Preventive maintenance.....	10
6	Drawing.....	11
7	Spare parts	12
8	Warranty	15

2.3 Connections

2.3.1 Compressed air connection



- Compressed air and electrical power may only be connected if
- valve is installed into a vacuum system
 - moving parts are protected against inadvertent contact

Connection: internal thread R 1/8" (1/8" NPT for USA)

Connection for compressed air supply: ⊙

Compressed air pressure (min. - max. overpressure): 6 - 9 bar / 85 - 130 psig
 Use only clean, dry or slightly lubricated air!

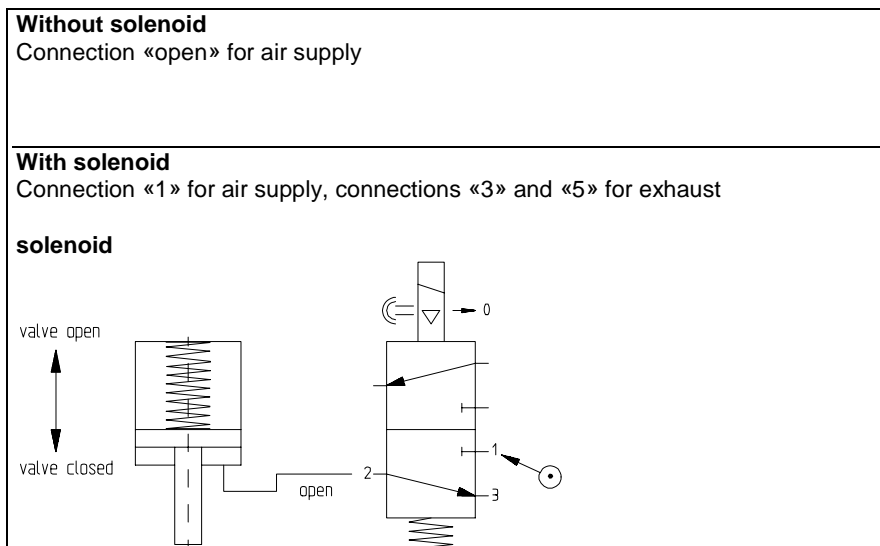

2.3.2 Electrical connection



Do not touch parts under voltage!



Connect electrical power only if

- valve is installed into the vacuum system
- moving parts cannot be touched

Verify that mains voltage matches voltage stated on the solenoid!

Sockets for position indicator and solenoid are supplied with the valve.

Wiring diagrams:

Solenoid



Position indicators for max. 80°C — contact rating ≤ 50 V AC / DC; ≤ 1.2 A

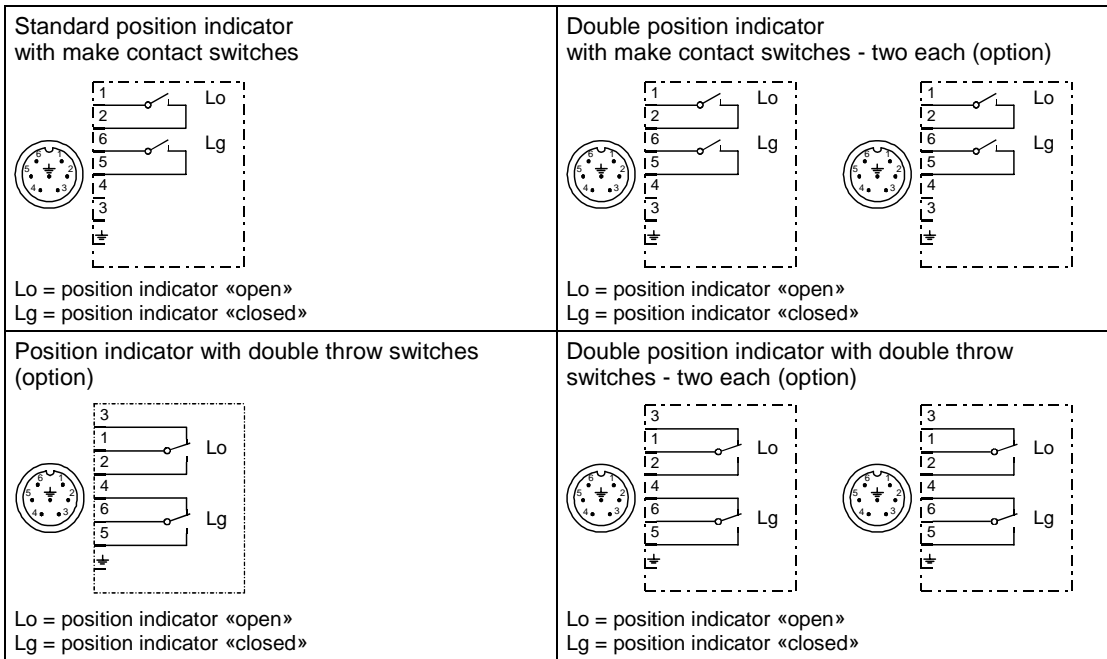

Position indicators for max. 200°C — contact rating ≤ 50 V AC / DC; ≤ 1 A

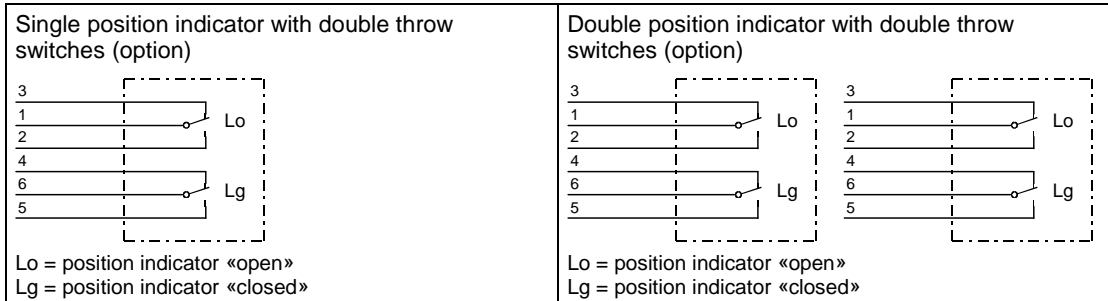

Position indicator for max. 80°C — contact rating ≤ 50 V AC / DC; ≤ 1.2 A

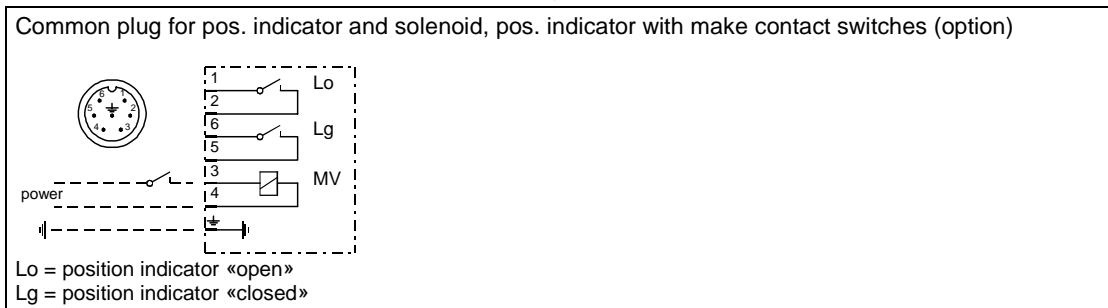

3 Operation

3.1 Normal operation

Opening of closed valve

- without solenoid:
 - air supply to connection plate 
- with solenoid:
 - supply specified control voltage to the coil

Closing of open valve

- without solenoid:
 - air release through connection plate 
- with solenoid:
 - release control voltage



Ascertain that the circlip connecting the lid to the cylinder is correctly in place. Even with disconnected supply, loaded springs and/or air cushions in cylinders can be potential hazards.

3.2 Bake out

Valve:	≤ 450 C in open position, 350°C in closed position
Actuator:	≤ 150°C
Position indicator:	≤ 80°C (option: 200°C)
Solenoid	≤ 80°C
Heating and cooling rate:	≤ 60°C/h

Operate the valve only after the bake-out temperature has been stable for two hours. If actuation during bake-out is required, the heating and cooling rate from 200°C to 450°C must not exceed 30°C/h.

Temperature differences exceeding 30°C throughout the valve are not allowed. They may affect the performance of the valve.

3.3 Operation under increased temperature

See «1.1 Technical data»

3.4 Behavior in case of compressed air pressure drop

Valve closed: valve remains closed and leaktight
 Valve open: valve closes

3.5 Behavior in case of power failure

solenoid: Valve closed: valve remains closed and leaktight
 Valve open: valve closes

3.6 Emergency operation at power failure

Solenoids is provided with a slotted screw to operate the valve in case of a power failure (with compressed air available)

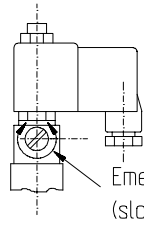
<p>Standard solenoid</p> <p>To <u>close</u> the valve: Turn the slotted screw counter-clockwise to its stop</p> <p>To <u>open</u> the valve: Turn the slotted screw clockwise to its stop</p> <p>For remote operation make sure that the slotted screw is turned counter-clockwise to its stop.</p>	 <p>Emergency operation (slotted screw)</p>
--	---

4 Trouble shooting

Failure	Check	Action
Valve mechanism does not mover:	Power available?	Check voltage!
	Compressed air available?	Check air pressure!
	Slotted screw of solenoid in proper position!	Check slotted screw!

If you need any further information, please contact one of our service centers. You can find the addresses on our website: <http://www.vat.ch>

5 Maintenance & repairs

Under clean operating conditions, the valve does not require any maintenance during the specified cycle life. Contamination from the process may influence the function and requires more frequent maintenance.

Before carrying out any maintenance or repairs, please contact VAT. It has to be individually decided whether the maintenance/repair can be performed by the customer or has to be carried out by VAT. The fabrication number on the valve

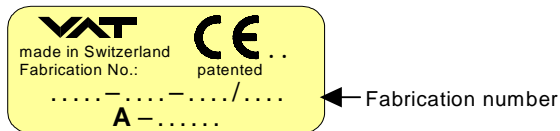

has always to be specified.

All supplies (e. g. compressed air, electrical power) must be disconnected for removal/installation of the valve from/into the system and for maintenance work.



Even with disconnected supply, loaded springs and/or air cushions in cylinders can be potential hazards.



Keep fingers and objects away from the valve opening!

Products returned to VAT must be free of harmful substances such as e.g. toxic, caustic or microbiological ones. If products are radioactively contaminated, fill in the VAT form «Contamination and Radiation Report» and send it with the product. The form is available at VAT. The maximum values indicated in the form must not be exceeded.



5.1 Preventive maintenance

Under clean operating conditions, the valve does not require any maintenance during the specified cycle life.

Instruction how to change the VATRING (Don't touch inside valve parts without gloves)

Note: The item numbers refer to the drawing on page 10.

- Open the valve and keep it open during the exchange (keep pressure air attached)
- Remove the bonnet screws (fig.69)
- Remove valve insert and bonnet seal (fig.36/2)
- When opening or tightening screw (fig.67) the bellows must be protected against turning (torsion) → see drawing
- Remove VATRING
- Take a lint free tissue dabbed with alcohol and clean all sealing surfaces (plate, bonnet, body seat and VATRING)
- Check sealing surfaces (visually) for scratches
- Clean VATRING and plate with clean and dry compressed air
- Place VATRING on sealing surface of the plate
- Align VATRING parallel with the frontal of the plate
- Place holding ring on top of plate
- Insert screw (fig.67), protects bellow against turning, tighten screw with a torque of 7Nm
- Place new bonnet seal (fig.36/2) exactly like shown in drawing!
- Put valve insert back into valve body and tighten bonnet screws in diagonal crosswise order with a torque of 7Nm

6 Drawing

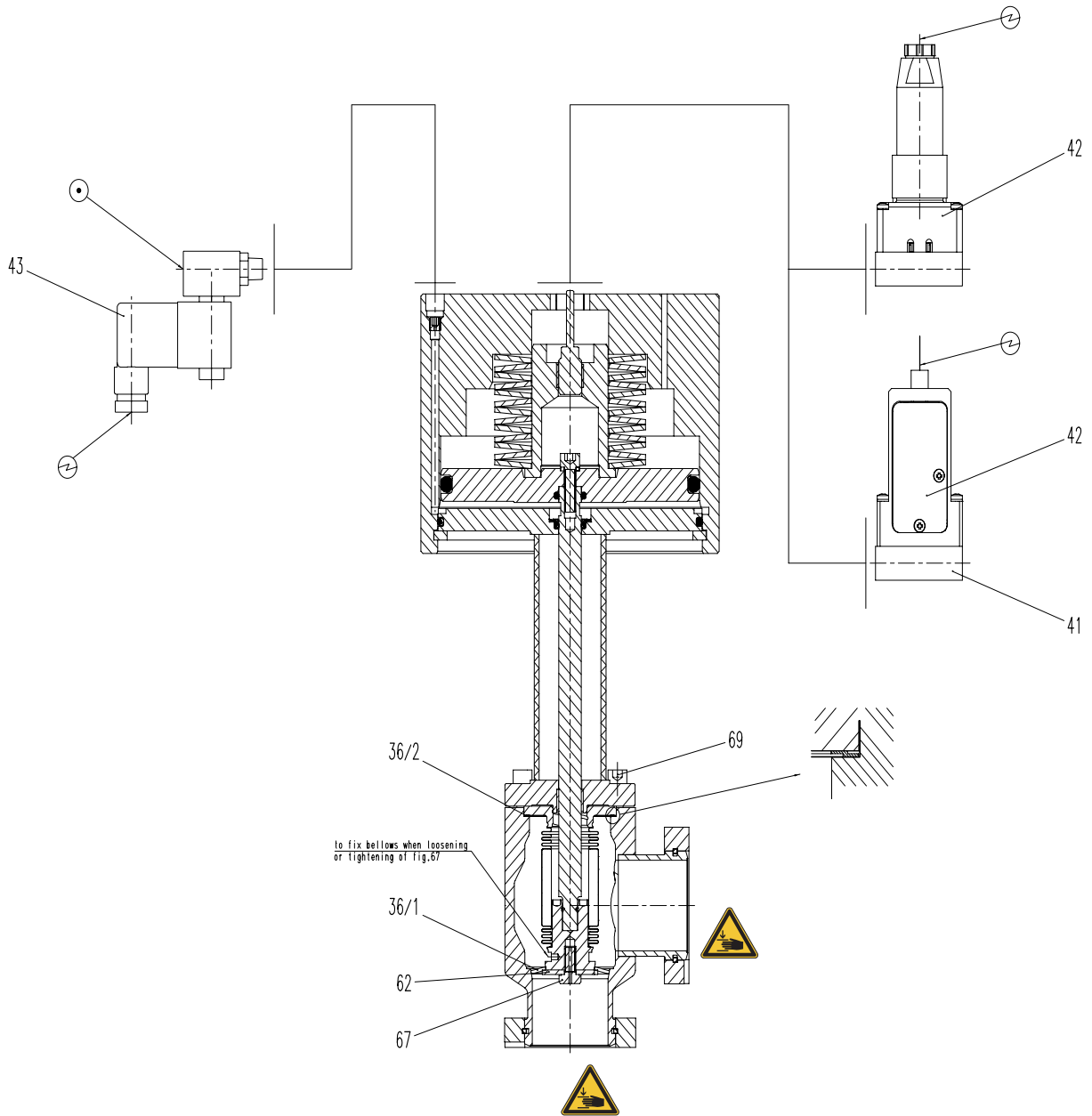



7 Spare parts



Please specify the **fabrication number of the valve** (see yellow label on valve) when ordering spare parts. This is to ensure that the appropriate spare parts are supplied.

Note: The item numbers refer to the drawing on page 11.

Item	Qty.	Description	Part number			
			57132- . E11	57132- . E21	57132- . E31	57132- . E41
36/1	1	VATRING	42372-01	42372-01	42372-01	42372-01
36/2	1	Bonnet seal	90367-01	90367-01	90367-01	90367-01
42	1	BS LM with control valve connection				313601
43	1	BS SV 3/2 Way			83666-R1	83666-R1
62	1	Holding ring	93854-01	93854-01	93854-01	93854-01
67	1	Screw with venting hole	N-5002-052	N-5002-052	N-5002-052	N-5002-052
69	6	Treated hexagon socket head cap screw	N-5019-790	N-5019-790	N-5019-790	N-5019-790

Position indicators 80°C (single) with adapter

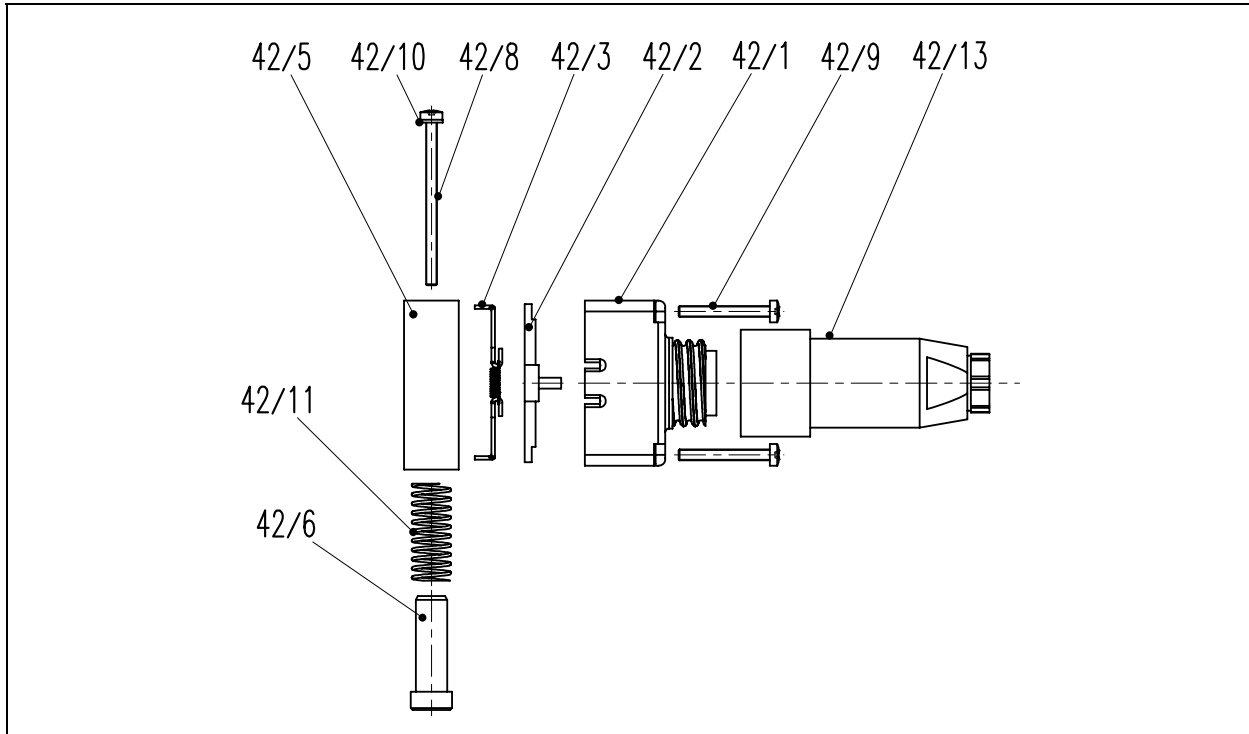

Item	Description	Version	Qty.	Part No.
			single	
42	BS Mini position indicator	double throw switches	1	211209
42/1	Position indicator		1	71852-R1
42/2	Slider		1	69846-01
42/3	Driving piece		1	69428-R1
42/5	Holder position indicator		1	80420-01
42/6	Bolt		1	80423-01
42/8	Screw		2	211199
42/9	Screw		4	N-6024-531
42/10	Spring ring		2	N-6160-406
42/11	Pressure spring		1	N-6240-303
42/13	Socket		1	N-8504-002

Position indicators 200°C (single)

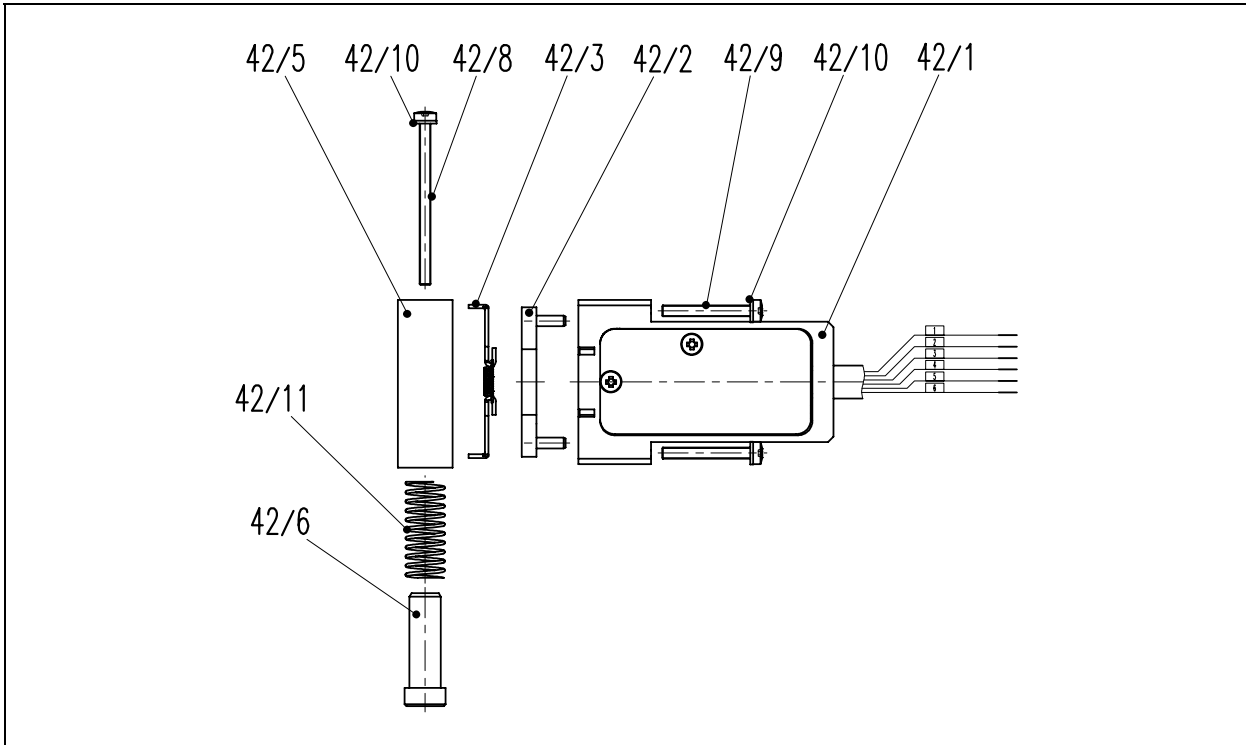

Item	Description	Version	Qty.	Part No.
			single	
42	BS Mini position indicator	double throw switches	1	330319
42/1	Position indicator		1	241824
42/2	Slider		1	241825
42/3	Driving piece		1	69428-R1
42/5	Holder position indicator		1	80420-01
42/6	Bolt		1	80423-01
42/8	Screw		2	211199
42/9	Screw		4	N-6024-531
42/10	Spring ring		6	N-6160-406
42/11	Pressure spring		1	N-6240-303



8 Warranty

Each product sold by VAT Vakuumventile AG (VAT) is warranted to be free from the manufacturing defects that adversely affect the normal functioning thereof during the warranty period stated in VAT's «Terms of Sale» immediately following delivery thereof by VAT, provided that the same is properly operated under conditions of normal use and that regular, periodic maintenance and service is performed or replacements made, in accordance with the instructions provided by VAT. The foregoing warranty shall not apply to any product or component that has been repaired or altered by anyone other than an authorized VAT representative or that has been subject to improper installation or abuse, misuse, negligence or accident. VAT shall not be liable for any damage, loss, or expense, whether consequential, special, incidental, direct or otherwise, caused by, arising out of or connected with the manufacture, delivery (including any delay in or failure to deliver), packaging, storage or use of any product sold or delivered by VAT shall fail to conform to the foregoing warranty or to the description thereof contained herein, the purchaser thereof, as its exclusive remedy, shall upon prompt notice to VAT of any such defect or failure and upon the return of the product, part or component in question to VAT at its factory, with transportation charges prepaid, and upon VAT's inspection confirming the existence of any defect inconsistent with said warranty or any such failure, be entitled to have such defect or failure cured at VAT's factory and at no charge therefor, by replacement or repair of said product, as VAT may elect. VAT MAKES NO WARRANTY OR REPRESENTATION OF ANY KIND, EXPRESS OR IMPLIED, (INCLUDING NO WARRANTY OR MERCHANTABILITY), EXCEPT FOR THE FOREGOING WARRANTY AND THE WARRANTY THAT EACH PRODUCT SHALL CONFORM TO THE DESCRIPTION THEREOF CONTAINED HEREIN, and no warranty shall be implied by law.

Furthermore, the «Terms of sale» at the back of the price list are applicable.